

EXISTING STORM POND

EXISTING RESIDENTIAL

CASCADE COMMONS

EXISTING RESIDENTIAL

EXISTING RESIDENTIAL

EXISTING RESIDENTIAL

SILVER MAPLE ROAD

PRIVATE OPEN SPACE

12 NONRES PARKING SPACES

BLOCK 2  
15 STOREY  
CONDOMINIUM  
(191 UNITS)

BLOCK 1  
15 STOREY  
CONDOMINIUM  
(251 UNITS)

BLOCK 3  
15 STOREY  
RENTAL  
(255 UNITS)

DUNDAS STREET EAST

POSTRIDGE DRIVE

TYPICAL STORAGE LOCKER :

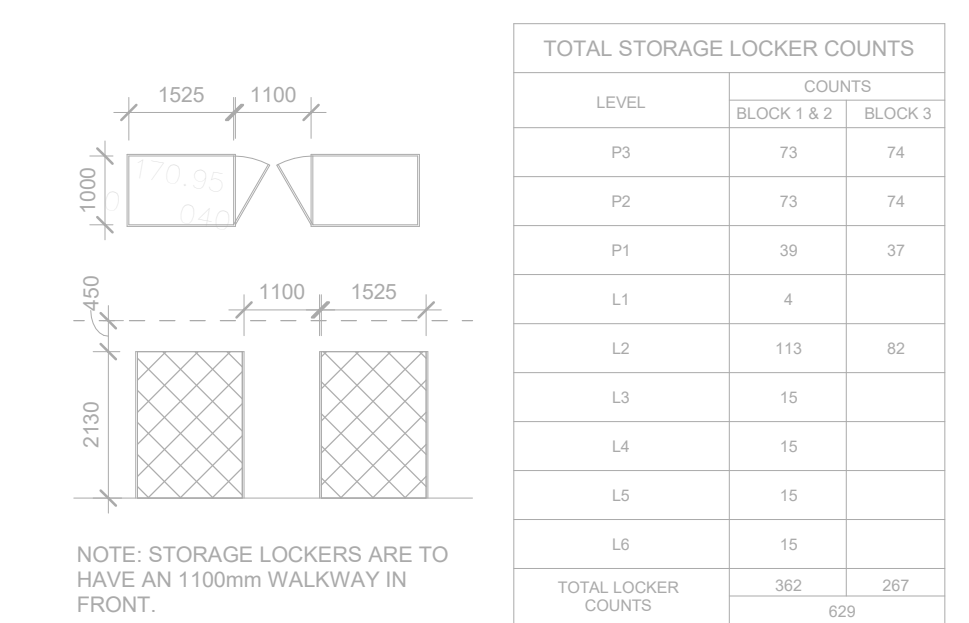

Locker Notes 4  
NTS dA1.3

TYPICAL BICYCLE PARKING SPACE :

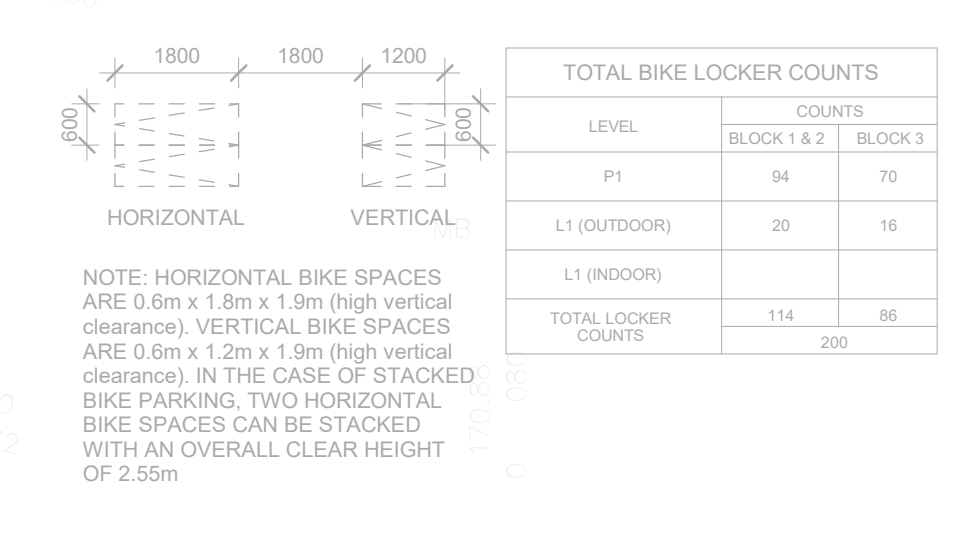

Bike Notes 5  
NTS dA1.3

HANDICAP PARKING SPACE :

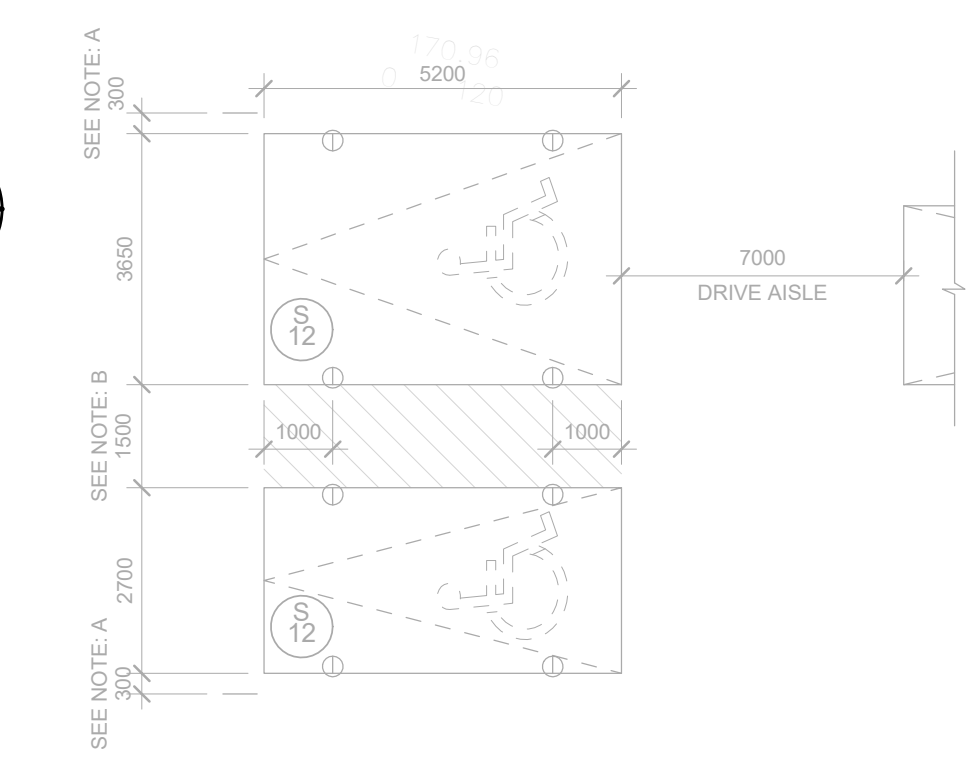

General Parking Notes 3  
NTS dA1.3

REGION OF HALTON DEVELOPMENT DESIGN GUIDELINES FOR SOURCE SEPARATION OF SOLID WASTE

WASTE MANAGEMENT NOTES :

Table with columns: WASTE COLLECTION & STORAGE, RECYCLING, ORGANICS, etc. Includes waste management notes and general notes.

Waste Management Notes 2  
NTS dA1.3

All Drawings, Specifications, and Related Documents are the Copyright of the Architect. The Architect retains all rights to control all uses of these documents for the intended jurisdiction as identified below. Reproduction of these documents, without permission from the Architect, is strictly prohibited. The Authorities Having Jurisdiction are permitted to copy, distribute, and reproduce these drawings for the intended purpose as noted and stated below, however the intended permission to the Authorities Having Jurisdiction is no way, in whole or in part, the Copyright of the Architect, or control of use of these documents by the Architect.



KIRKOR ARCHITECTS AND PLANNERS  
20 De Boers Dr. # 400 Toronto ON M3J 0H1  
Tel: 416 665 6060 kirkorarchitects.com

Revisions: \_\_\_\_\_  
No. \_\_\_\_\_ Revision: \_\_\_\_\_ Date: \_\_\_\_\_

01 SPA Submission #1 March 29, 2021  
No. Issued For: \_\_\_\_\_ Date: \_\_\_\_\_

Site Plan

Client:  
Daniels Emshoh OakVillage Corporation

Project:  
OakVillage

377 Dundas St E (Block 1), 387 Dundas St E (Block 2), 411 Dundas St E (Block 3)  
OakVillage, Ontario  
Proposed Residential Development

Scale:  
As indicated  
Drawn by: LG, CK  
Checked by: BW  
Project No.: 20-058  
Date: March 29, 2021  
Drawing No.: \_\_\_\_\_

Site Plan 1  
1 : 200 dA1.3