

EXISTING STORM POND

EXISTING RESIDENTIAL

EXISTING RESIDENTIAL

CASCADE COMMONS

EXISTING RESIDENTIAL

EXISTING RESIDENTIAL

EXISTING RESIDENTIAL

SILVER MAPLE ROAD

PRIVATE OPEN SPACE

16 TOTAL PARKING SPACES
(NON-RESIDENTIAL / VISITOR
COMINGLED)

BLOCK 1
17 STOREY
RESIDENTIAL
(265 SUITES)

RESIDENTIAL
ENTRANCE
BLOCK 3

BLOCK 2
15 STOREY
RESIDENTIAL
(180 SUITES)

NON RES.
ENTRANCE

RESIDENTIAL
ENTRANCE
BLOCK 3

BLOCK 3
15 STOREY
RESIDENTIAL
(254 SUITES)

OUTDOOR AMENITY
ROOF AT LEVEL 7
(6 STOREY)

MOVING ROOM
BLDG 2

OUTDOOR AMENITY
ROOF AT LEVEL 14
(13 STOREY)

PRIMARY
RESIDENTIAL
ENTRANCE
BLOCK 3

22.6 meters

6.2 meters

31.1 meters

5 meters

24.5 meters

15 meters

48.8 meters

FIRE ROUTE

DUNDAS STREET EAST

POSTRIDGE DRIVE

TYPICAL STORAGE LOCKER :

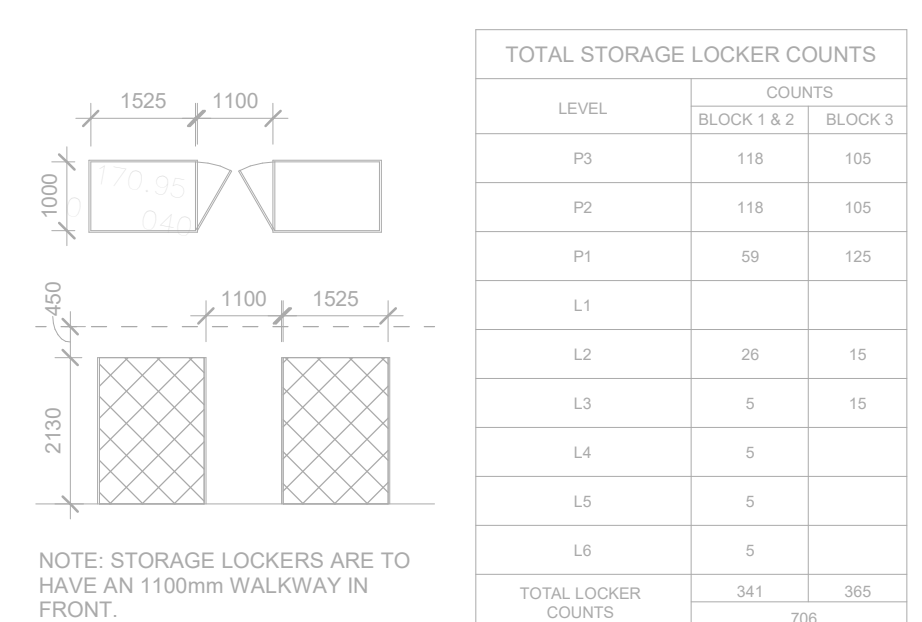

Locker Notes 4 NTS dA1.3

TYPICAL BICYCLE PARKING SPACE :

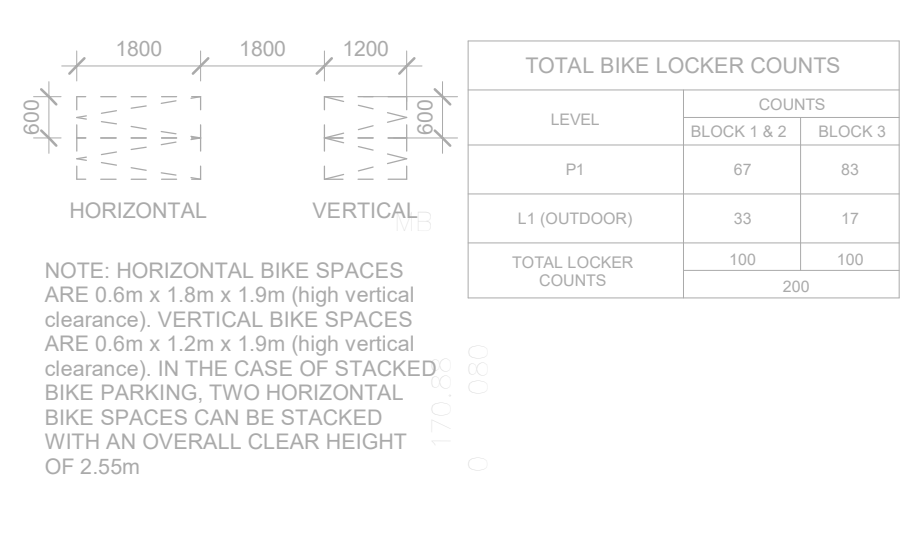

Bike Notes 5 NTS dA1.3

TYPICAL PARKING SPACE:
Drive Aisle @ 7m min.

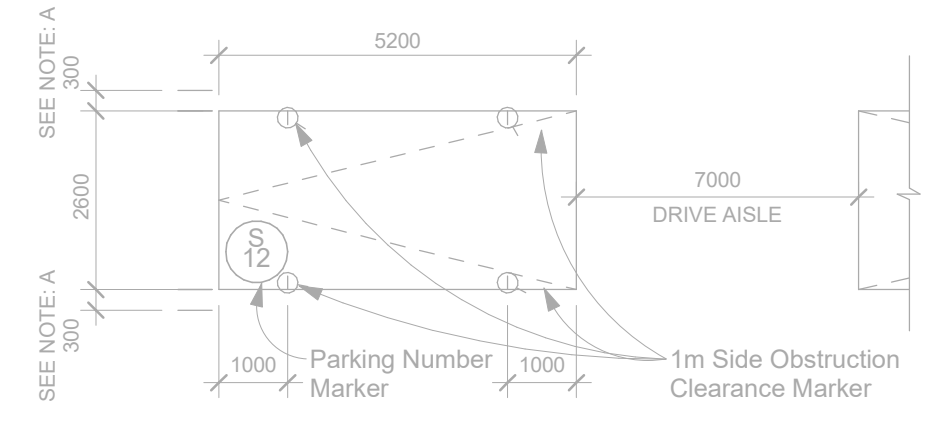

HANDICAP PARKING SPACE:

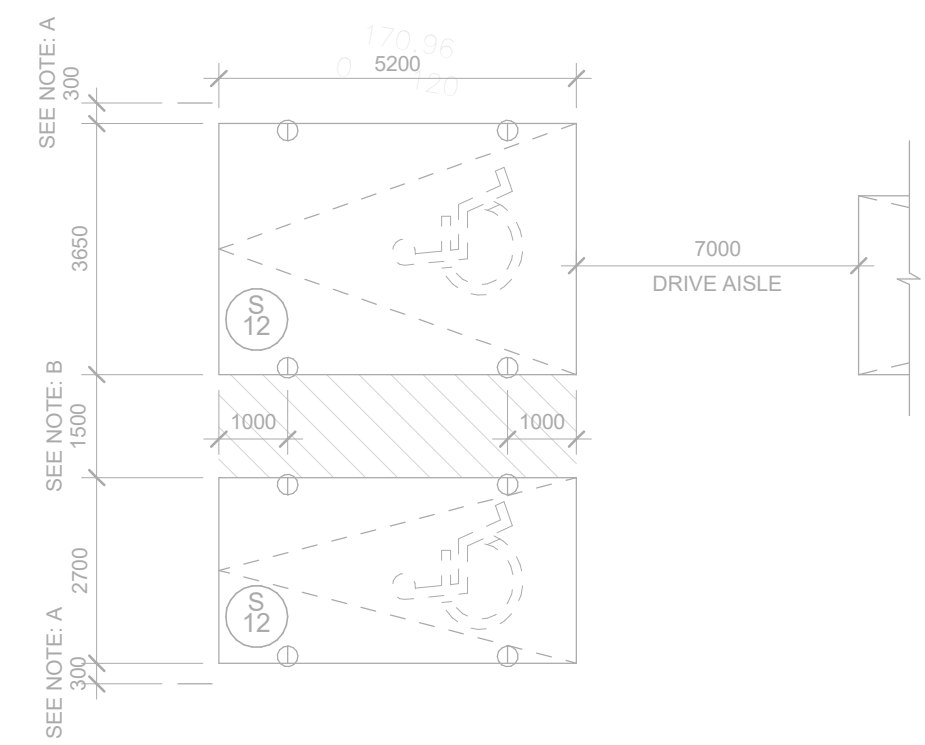

General Parking Notes 3 NTS dA1.3

REGION OF HALTON DEVELOPMENT DESIGN GUIDELINES FOR SOURCE SEPARATION OF SOLID WASTE

WASTE MANAGEMENT NOTES :

Table with columns: WASTE COLLECTION & STORAGE, RECYCLING, ORGANICS, etc.

WASTE MANAGEMENT NOTES: ALL GARAGE AND RECYCLING RECEPTACLES ARE 3 CUBIC YARD BINS PER THE HALTON REGION WASTE COLLECTION STANDARDS...

GENERAL NOTES: A TRAINED ON-SITE STAFF TO BE AVAILABLE TO MANEUVER THE WASTE COLLECTION BINS...

IT IS NOT EXPECTED THAT ALL RECEPTACLES ARE BEING PICKED UP ON ONE COLLECTION TIME.

Waste Management Notes 2 NTS dA1.3

All Drawings, Specifications, and Related Documents are the Copyright of the Architect. The Architect retains all rights to control all uses of these documents...

This Drawing is Not To Be Used For Construction Until Signed By The Architect.



KIRKOR ARCHITECTS AND PLANNERS
20 De Boers Dr. # 400 Toronto ON M3J 0H1
Tel: 416 665 6060 kirkorarchitects.com

Revisions: No. Revision Date

Table with columns: No., Issued For, Date, Drawing Title

Site Plan
Daniels Emshik OakVillage Corporation

Project:
OakVillage

377 Dundas St E (Block 1), 387 Dundas St E (Block 2), 411 Dundas St E (Block 3)
OakVillage, Ontario
Proposed Residential Development

As indicated
LG, CK
BW
20-058
December 17, 2021

Site Plan 1 dA1.3
1 : 200

