

BENCHMARK: ELEV. 85.407
 ELEVATIONS ARE GEODETIC AND ARE REFERRED TO TOWN OF OAKVILLE VERTICAL BENCH MARK NUMBER 188 HAVING AN ORTHOMETRIC ELEVATION OF 85.407 METERS. ELEVATIONS ARE REFERENCED TO THE CANADIAN GEODETIC VERTICAL DATUM OF 1925, PRE-1978 ADJUSTMENT (CGVD-1928-PRE-1978 ADJ.).

LEGEND:

	LIMIT OF DEVELOPMENT
	LIMIT OF SUBDIVISION
	EROSION SEDIMENTATION CONTROL SILT FENCE (SEE DETAIL ON DRAWING ESC-3)
	TREE PRESERVATION FENCE (SEE DETAIL ON DRAWING ESC-3)
	EXISTING CONTOUR AND ELEVATION
	EXISTING STORM DRAINAGE BOUNDARY
	SWALE ELEVATION
	SWALE (SEE DETAIL ON DRAWING ESC-3)
	TEMPORARY CONSTRUCTION ACCESS (SEE DETAIL ON DRAWING ESC-3)
	EXISTING FLOW DIRECTION
	DRAINAGE AREA (ha)
	TEMPORARY STREET CATCHBASIN SEDIMENT CONTROL DEVICE (SEE DETAIL ON DRAWING ESC-3)
	TEMPORARY FILTER CHECK DAM (SEE DETAIL ON DRAWING ESC-3)
	LOCKABLE GATE (SEE DETAIL ON DRAWING ESC-3)
	EXISTING TREE TO BE REMOVED (REFER TO DRAWING T1-1 PREPARED BY MHBC)
	TEMPORARY SEDIMENT TRAP (SEE DRAWING ESC-3)

NOTE
 TREE REMOVAL AND TREE TRIMMING SHOULD OCCUR OUTSIDE THE MIGRATORY BREEDING BIRD WINDOW APRIL 1 - AUGUST 31

TOPOGRAPHIC SURVEY PROVIDED BY RPE SURVEYING LTD, MAY 2017

REVISIONS				
No.	DESCRIPTION	DATE	BY	APPROVED
1.	FIRST SUBMISSION	APR 28/23	K.L.	P.G.
2.	ISSUED FOR SITE PLAN APPLICATION - 2nd SUBMISSION	OCT 14/22	K.L.	P.G.
3.	ISSUED FOR SITE PLAN APPLICATION - 3rd SUBMISSION	JAN 20/23	K.L.	P.G.
4.	ISSUED FOR SITE PLAN APPLICATION - 4th SUBMISSION	JUN 28/23	K.L.	P.G.

SCS consulting group ltd
 30 CENTURIAN DRIVE, SUITE 100
 MARKHAM, ONTARIO L3R 8B8
 TEL: (905) 475-1900
 FAX: (905) 475-8335

OAKVILLE
 1235 TRAFALGAR ROAD
 OAKVILLE, ONTARIO L6H 0H3
 TEL: (905) 845-6601
 FAX: (905) 815-2025

3171 LAKESHORE ROAD WEST, OAKVILLE

EROSION AND SEDIMENT CONTROL - STAGE 1 DEMOLITION AND TOPSOIL STRIPPING

DATE: JUNE 2023 DESIGNED BY: K.L. CHECKED BY: P.G.
 SCALE: 1:250 DRAWN BY: K.L. CHECKED BY: P.G.

PROJECT No: **1930**
 DRAWING No: **ESC-1**

PROFESSIONAL ENGINEER
 N. D. MCINTOSH
 100230564
 June 28, 2023
 PROVINCE OF ONTARIO

- GENERAL NOTES**
- THE OWNER IS RESPONSIBLE FOR OBTAINING ALL NECESSARY APPROVALS FROM THE MUNICIPALITY AND ANY REQUIRED EXTERNAL AGENCIES PRIOR TO ANY SITE ALTERATION ACTIVITY.
 - PRIOR TO COMMENCEMENT OF ANY SITE ALTERATION ACTIVITY, EROSION & SEDIMENT CONTROL (ESC) MEASURES, AS PER APPROVED EROSION SEDIMENT CONTROL PLAN, MUST BE INSTALLED. ADDITIONAL ESC MEASURES, IF REQUIRED, SHALL BE INSTALLED AS DIRECTED BY THE MUNICIPALITY. THE ESC MEASURES SHALL REMAIN IN PLACE UNTIL DIRECTED BY THE MUNICIPALITY/CIVIL CONSULTANT FOR THEIR REMOVAL. FLOWS TO BE DIRECTED TO SWALES ONLY AFTER THEY HAVE BEEN STABILIZED.
 - NO CONSTRUCTION ACTIVITY OR MACHINERY SHALL BE ALLOWED BEYOND THE SEDIMENT CONTROL/SNOW/TREE PRESERVATION FENCE OR LIMITS OF THE PROPERTY.
 - THE CONTRACTOR IS RESPONSIBLE TO IMPLEMENT DUST CONTROL MEASURES AND CONSTRUCTION PRACTICE GUIDELINES AS APPROVED BY THE TOWN OF OAKVILLE.
 - THE CONTRACTOR IS RESPONSIBLE FOR MAINTAINING ALL ESC MEASURES IN WORKING CONDITIONS AT ALL TIMES TO THE SATISFACTION OF THE TOWN OF OAKVILLE. THE CONTRACTOR SHALL ROUTINELY INSPECT ALL ESC DEVICES AT A MINIMUM OF ONCE A WEEK AND AFTER EACH SIGNIFICANT SNOW MELT AND RAINFALL GREATER THAN 10mm TO ENSURE THAT ESC MEASURES ARE IN PROPER WORKING CONDITION. DURING INACTIVE PERIODS, WHERE THE SITE HAS LITTLE OR NO CONSTRUCTION ACTIVITY FOR 30 DAYS OR LONGER, A MONTHLY INSPECTION WILL BE CONDUCTED. ANY DAMAGES MUST BE REPAIRED WITHIN 48 HOURS.
 - ALL CONSTRUCTION VEHICLES MUST ENTER AND EXIT THE SITE ONLY FROM THE APPROVED ACCESS ROUTE AS SHOWN. TEMPORARY CONSTRUCTION ACCESS WILL BE MAINTAINED TO THE SATISFACTION OF THE TOWN OF OAKVILLE. STREET SWEEPING MAY BE REQUIRED AS NEEDED.
 - ALL DISTURBED GROUND LEFT INACTIVE, OR TO BE LEFT INACTIVE, FOR OVER 30 DAYS SHALL BE STABILIZED AS SOON AS POSSIBLE, SUBJECT TO WEATHER CONDITIONS, BY SEEDING (SUCH AS OATS) OR APPROVED EQUIVALENT TO THE SATISFACTION OF THE TOWN OF OAKVILLE. TOPSOIL RE-VEGETATION AND HYDROSEEDING TO BE PER OPS 570 AND 572.
 - THE EROSION & SEDIMENT CONTROL STRATEGIES OUTLINED ON THIS PLAN ARE NOT STATIC AND MAY NEED TO BE UPGRADED/AMENDED AS SITE CONDITIONS CHANGE TO PREVENT SEDIMENT RELEASES TO THE NATURAL ENVIRONMENT.
 - CONTRACTOR TO CONFIRM THE LOCATION OF THE EXISTING UTILITIES PRIOR TO INITIATING ANY ON-SITE WORKS.
 - TREES ARE TO BE PRESERVED OR REMOVED AS PER THE APPROVED TREE PRESERVATION PLAN. PREPARED BY MHBC ON NOVEMBER 11, 2020.
 - EROSION AND SEDIMENT CONTROL INSPECTION IS TO BE CONDUCTED BY A QUALIFIED AND / OR CERTIFIED PROFESSIONAL (i.e. GECI) AND REPORTS ARE TO BE SUBMITTED TO THE TOWN OF OAKVILLE'S DEVELOPMENT INSPECTOR AND ANY OTHER RELEVANT STAFF AS REQUIRED BY THE TOWN OF OAKVILLE.
 - CONTRACTOR TO ENSURE THAT SEDIMENT LADEN RUNOFF IS DIRECTED TO APPROPRIATE ESC CONTROLS THROUGHOUT THE STAGED CONSTRUCTION PROCESS, INCLUDING TRANSITIONAL WORKS BETWEEN STAGES.
 - ALL ACTIVITIES, INCLUDING MAINTENANCE PROCEDURES, WILL BE CONTROLLED TO PREVENT THE ENTRY OF PETROLEUM PRODUCTS, DEBRIS, RUBBLE, CONCRETE OR OTHER DELETERIOUS SUBSTANCES INTO THE DOWNSTREAM ENVIRONMENT. REFUELING AND MAINTENANCE WILL BE CONDUCTED 30m FROM ANY WATERCOURSE.
 - WHERE A SITE REQUIRES DEWATERING AND WHERE THE EXPELLED WATER CAN BE FREELY RELEASED TO A SUITABLE RECEIVER, THE EXPELLED WATER SHALL BE TREATED TO CAPTURE SUSPENDED PARTICLES GREATER THAN 50 MICROM IN SIZE. THE CAPTURED SEDIMENT SHALL BE DISPOSED OF PROPERLY PER MOECC GUIDELINES. THE CLEAN EXPELLED WATER SHALL FREELY RELEASE TO A SUITABLE RECEIVER THAT DOES NOT CREATE DOWNSTREAM ISSUES INCLUDING BUT NOT LIMITED TO EROSION, FLOODING, NUISANCE OR OTHERWISE, INTERFERENCE ISSUES, ETC.
 - EXISTING STORM SEWER AND DRAINAGE DITCHES ADJACENT TO THE WORKS SHALL BE PROTECTED AT ALL TIMES FROM THE ENTRY OF SEDIMENT/SILT THAT MAY MIGRATE FROM THE SITE. FOR STORM SEWERS: ALL INLETS (BEAR LOT CATCHBASINS, ROAD CATCHBASINS, PIPE INLETS, ETC.) MUST BE SECURED/FITTED WITH SITUATION CONTROL MEASURES. FOR DRAINAGE DITCHES: THE INSTALLATION OF ROCK CHECK DAMS, SITUATION FENCE, SEDIMENT CONTAINMENT DEVICES MUST BE INSTALLED TO TRAP AND CONTAIN SEDIMENT.
 - IN THE EVENT OF A SPILL (RELEASE OF DELETERIOUS MATERIAL) ON OR EMANATING FROM THE SITE, THE OWNER OR OWNERS AGENT SHALL IMMEDIATELY NOTIFY THE MOECC AND FOLLOW ANY PRESCRIBED CLEAN UP PROCEDURE. THE OWNER OR OWNERS AGENT WILL IMMEDIATELY NOTIFY THE TOWN.
 - SHORT TERM DISCHARGE OF GROUNDWATER IF NECESSARY MUST MEET REQUIREMENTS OUTLINED IN TOWN OF OAKVILLE STORM SEWER BY LAW (2009-031) AT ALL TIMES.
- ESC STAGE 1 - DEMOLITION AND TOPSOIL STRIPPING NOTES**
- ALL TEMPORARY SEDIMENT CONTROLS (I.E. FENCING, CHECK DAMS AND CONSTRUCTION ACCESS) TO BE INSTALLED AND INSPECTED BY THE TOWN OF OAKVILLE HILL PRIOR TO ANY TOPSOIL STRIPPING WORKS.
 - TEMPORARY INTERCEPTOR SWALES ALONG THE SITE PERIMETER TO BE SEEDDED WITH NURSERY COVER CROP (SUCH AS OATS, BARLEY, CANADA WILD RYE, WINTER WHEAT, OR BUCKWHEAT) USING HYDROSEEDING AND STABILIZED WITH EROSION CONTROL BLANKETS (LAYERED LPS-1, 1" OF FILTREX GROWTH MEDIA) OR APPROVED EQUIVALENT) WITHIN 48 HOURS FOLLOWING SWALE GRADING.
 - SURFACE ROUGHENING TO TAKE PLACE WHEREVER POSSIBLE AS A MEANS OF TEMPORARY EROSION AND SEDIMENT CONTROL. SURFACE ROUGHENING TO BE ACHIEVED BY TRACKWALKING PERPENDICULAR TO THE DIRECTION OF FLOW OR WITH A SHEEP'S FOOT PCKER.

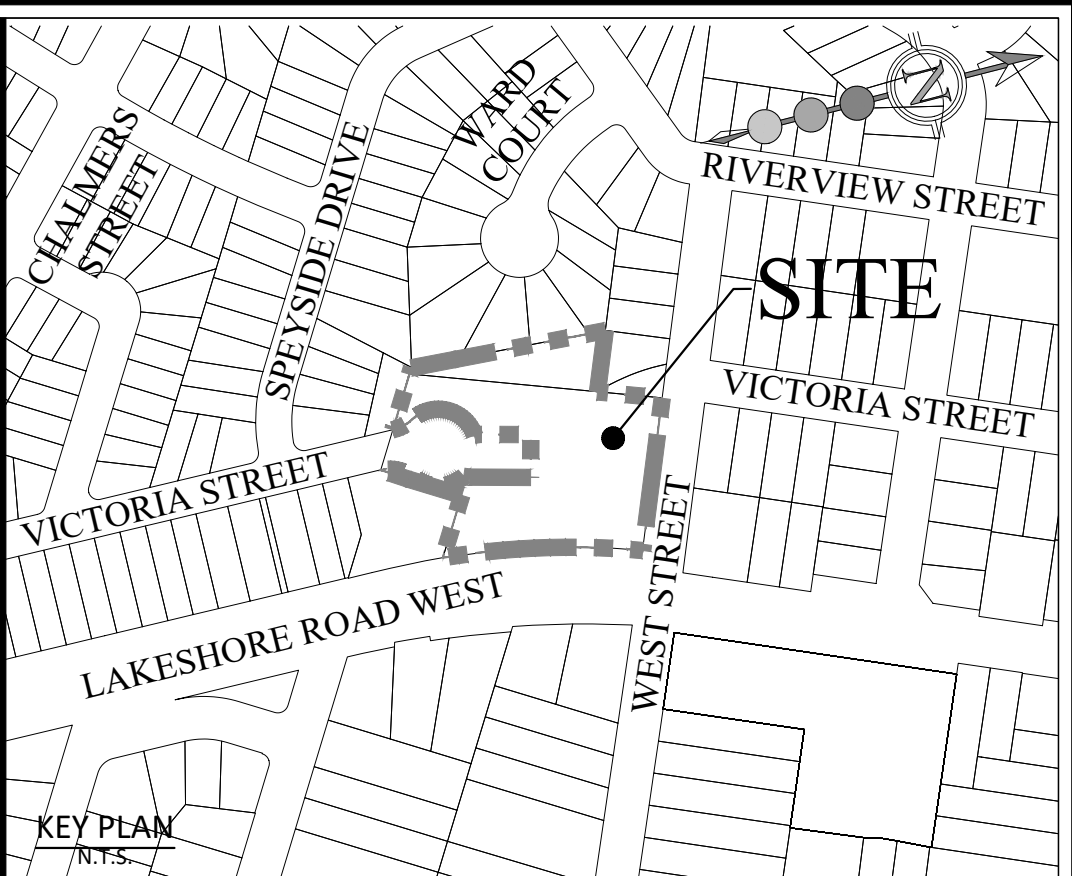
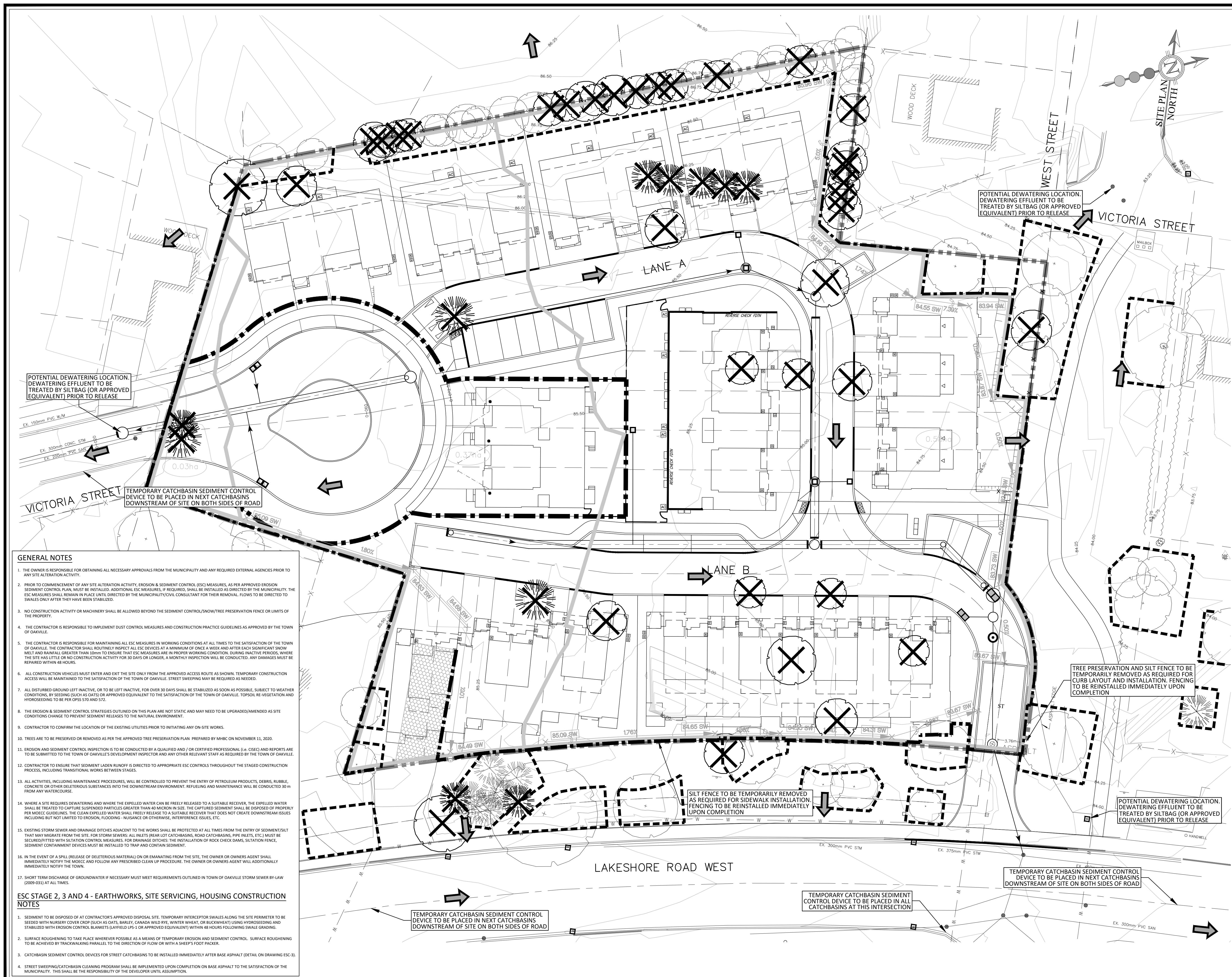

BENCHMARK: ELEV. 85.407
 ELEVATIONS ARE GEODETIC AND ARE REFERRED TO TOWN OF OAKVILLE VERTICAL BENCH MARK NUMBER 188 HAVING AN ORTHOMETRIC ELEVATION OF 85.407 METERS. ELEVATIONS ARE REFERENCED TO THE CANADIAN GEODETIC VERTICAL DATUM OF 1925, PRE-1978 ADJUSTMENT (CGVD-1928-PRE-1978 ADJ.).

LEGEND:

	LIMIT OF DEVELOPMENT
	LIMIT OF SUBDIVISION
	EROSION SEDIMENTATION CONTROL SILT FENCE (SEE DETAIL ON DRAWING ESC-3)
	TREE PRESERVATION FENCE (SEE DETAIL ON DRAWING ESC-3)
	EXISTING CONTOUR AND ELEVATION
	EXISTING STORM DRAINAGE BOUNDARY
	SWALE ELEVATION
	SWALE (SEE DETAIL ON DRAWING ESC-3)
	TEMPORARY CONSTRUCTION ACCESS
	DRAINAGE AREA (ha)
	PROPOSED FLOW DIRECTION
	TEMPORARY STREET CATCHBASIN SEDIMENT CONTROL DEVICE (SEE DETAIL ON DRAWING ESC-3)
	TEMPORARY FILTER CHECK DAM (SEE DETAIL ON DRAWING ESC-3)
	LOCKABLE GATE (SEE DETAIL ON DRAWING ESC-3)
	PROPOSED STORM SEWER AND MANHOLE
	PROPOSED SUPERPIPE
	EXISTING TREE TO BE REMOVED (REFER TO DRAWING TI-1 PREPARED BY MHBC)
	TEMPORARY SEDIMENT TRAP (SEE DRAWING ESC-3)

GENERAL NOTES

- THE OWNER IS RESPONSIBLE FOR OBTAINING ALL NECESSARY APPROVALS FROM THE MUNICIPALITY AND ANY REQUIRED EXTERNAL AGENCIES PRIOR TO ANY SITE ALTERATION ACTIVITY.
- PRIOR TO COMMENCEMENT OF ANY SITE ALTERATION ACTIVITY, EROSION & SEDIMENT CONTROL (ESC) MEASURES, AS PER APPROVED EROSION SEDIMENT CONTROL PLAN, MUST BE INSTALLED. ADDITIONAL ESC MEASURES, IF REQUIRED, SHALL BE INSTALLED AS DIRECTED BY THE MUNICIPALITY. THE ESC MEASURES SHALL REMAIN IN PLACE UNTIL DIRECTED BY THE MUNICIPALITY/CIVIL CONSULTANT FOR THEIR REMOVAL. FLOWS TO BE DIRECTED TO SWALES ONLY AFTER THEY HAVE BEEN STABILIZED.
- NO CONSTRUCTION ACTIVITY OR MACHINERY SHALL BE ALLOWED BEYOND THE SEDIMENT CONTROL/SNOW/TREE PRESERVATION FENCE OR LIMITS OF THE PROPERTY.
- THE CONTRACTOR IS RESPONSIBLE TO IMPLEMENT DUST CONTROL MEASURES AND CONSTRUCTION PRACTICE GUIDELINES AS APPROVED BY THE TOWN OF OAKVILLE.
- THE CONTRACTOR IS RESPONSIBLE FOR MAINTAINING ALL ESC MEASURES IN WORKING CONDITIONS AT ALL TIMES TO THE SATISFACTION OF THE TOWN OF OAKVILLE. THE CONTRACTOR SHALL ROUTINELY INSPECT ALL ESC DEVICES AT A MINIMUM OF ONCE A WEEK AND AFTER EACH SIGNIFICANT SNOW MELT AND RAINFALL GREATER THAN 10mm TO ENSURE THAT ESC MEASURES ARE IN PROPER WORKING CONDITION. DURING INACTIVE PERIODS, WHERE THE SITE HAS LITTLE OR NO CONSTRUCTION ACTIVITY FOR 30 DAYS OR LONGER, A MONTHLY INSPECTION WILL BE CONDUCTED. ANY DAMAGES MUST BE REPAIRED WITHIN 48 HOURS.
- ALL CONSTRUCTION VEHICLES MUST ENTER AND EXIT THE SITE ONLY FROM THE APPROVED ACCESS ROUTE AS SHOWN. TEMPORARY CONSTRUCTION ACCESS SHALL BE MAINTAINED TO THE SATISFACTION OF THE TOWN OF OAKVILLE. STREET SWEEPING MAY BE REQUIRED AS NEEDED.
- ALL DISTURBED GROUND LEFT INACTIVE, OR TO BE LEFT INACTIVE, FOR OVER 30 DAYS SHALL BE STABILIZED AS SOON AS POSSIBLE, SUBJECT TO WEATHER CONDITIONS, BY SEEDING (SUCH AS OATS) OR APPROVED EQUIVALENT TO THE SATISFACTION OF THE TOWN OF OAKVILLE. TOPSOIL RE-VEGETATION AND HYDROSEEDING TO BE PER OPS 570 AND 572.
- THE EROSION & SEDIMENT CONTROL STRATEGIES OUTLINED ON THIS PLAN ARE NOT STATUTE AND MAY NEED TO BE UPGRADED/AMENDED AS SITE CONDITIONS CHANGE TO PREVENT SEDIMENT RELEASES TO THE NATURAL ENVIRONMENT.
- CONTRACTOR TO CONFIRM THE LOCATION OF THE EXISTING UTILITIES PRIOR TO INITIATING ANY ON-SITE WORKS.
- TREES ARE TO BE PRESERVED OR REMOVED AS PER THE APPROVED TREE PRESERVATION PLAN PREPARED BY MHBC ON NOVEMBER 11, 2020.
- EROSION AND SEDIMENT CONTROL INSPECTION IS TO BE CONDUCTED BY A QUALIFIED AND/OR CERTIFIED PROFESSIONAL (I.E. CISEC) AND REPORTS ARE TO BE SUBMITTED TO THE TOWN OF OAKVILLE'S DEVELOPMENT INSPECTOR AND ANY OTHER RELEVANT STAFF AS REQUIRED BY THE TOWN OF OAKVILLE.
- CONTRACTOR TO ENSURE THAT SEDIMENT LADEN RUNOFF IS DIRECTED TO APPROPRIATE ESC CONTROLS THROUGHOUT THE STAGED CONSTRUCTION PROCESS, INCLUDING TRANSITIONAL WORKS BETWEEN STAGES.
- ALL ACTIVITIES, INCLUDING MAINTENANCE PROCEDURES, WILL BE CONTROLLED TO PREVENT THE ENTRY OF PETROLEUM PRODUCTS, DEBRIS, RUBBLE, CONCRETE OR OTHER DELETERIOUS SUBSTANCES INTO THE DOWNSTREAM ENVIRONMENT. REFUELING AND MAINTENANCE WILL BE CONDUCTED 50m FROM ANY WATERCOURSE.
- WHERE A SITE REQUIRES DEWATERING AND WHERE THE DEWATERED WATER CAN BE FREELY RELEASED TO A SUITABLE RECEIVER, THE DEWATERED WATER SHALL BE TREATED TO CAPTURE SUSPENDED PARTICLES GREATER THAN 40 MICRON IN SIZE. THE CAPTURED SEDIMENT SHALL BE DISPOSED OF PROPERLY PER MOECC GUIDELINES. THE CLEAN EXPELLED WATER SHALL FREELY RELEASE TO A SUITABLE RECEIVER THAT DOES NOT CREATE DOWNSTREAM ISSUES INCLUDING BUT NOT LIMITED TO EROSION, FLOODING, NUISANCE OR OTHERWISE, INTERFERENCE ISSUES, ETC.
- EXISTING STORM SEWER AND DRAINAGE DITCHES ADJACENT TO THE WORKS SHALL BE PROTECTED AT ALL TIMES FROM THE ENTRY OF SEDIMENT/SILT THAT MAY MIGRATE FROM THE SITE. FOR STORM SEWERS: ALL INLETS BEHIND LOT CATCHBASINS, ROAD CATCHBASINS, PIPE INLETS, ETC. MUST BE SECURED/FITTED WITH SILTATION CONTROL MEASURES. FOR DRAINAGE DITCHES: THE INSTALLATION OF ROCK CHECK DAMS, SILTATION FENCE, SEDIMENT CONTAINMENT DEVICES MUST BE INSTALLED TO TRAP AND CONTAIN SEDIMENT.
- IN THE EVENT OF A SPILL (RELEASE OF DELETERIOUS MATERIAL) ON OR EMANATING FROM THE SITE, THE OWNER OR OWNERS AGENT SHALL IMMEDIATELY NOTIFY THE MOECC AND FOLLOW ANY PRESCRIBED CLEAN UP PROCEDURE. THE OWNER OR OWNERS AGENT WILL ADDITIONALLY IMMEDIATELY NOTIFY THE TOWN.
- SHORT TERM DISCHARGE OF GROUNDWATER IF NECESSARY MUST MEET REQUIREMENTS OUTLINED IN TOWN OF OAKVILLE STORM SEWER BY-LAW (2009-033) AT ALL TIMES.

ESC STAGE 2, 3 AND 4 - EARTHWORKS, SITE SERVICING, HOUSING CONSTRUCTION NOTES

- SEDIMENT TO BE DISPOSED OF AT CONTRACTOR'S APPROVED DISPOSAL SITE. TEMPORARY INTERLOCK FOR SWALES ALONG THE SITE PERIMETER TO BE SEEDED WITH NURSERY COVER CROP (SUCH AS OATS, BARLEY, CANADA WILD RYE, WINTER WHEAT, OR BUCKWHEAT) USING HYDROSEEDING AND STABILIZED WITH EROSION CONTROL BLANKETS (LAYFIELD LPS-1 OR APPROVED EQUIVALENT) WITHIN 48 HOURS FOLLOWING SWALE GRADING.
- SURFACE ROUGHENING TO TAKE PLACE WHEREVER POSSIBLE AS A MEANS OF TEMPORARY EROSION AND SEDIMENT CONTROL. SURFACE ROUGHENING TO BE ACHIEVED BY TRACKWALKING PARALLEL TO THE DIRECTION OF FLOW OR WITH A SHEEP'S FOOT PCKER.
- CATCHBASIN SEDIMENT CONTROL DEVICES FOR STREET CATCHBASINS TO BE INSTALLED IMMEDIATELY AFTER BASE ASPHALT (DETAIL ON DRAWING ESC-3).
- STREET SWEEPING/CATCHBASIN CLEANING PROGRAM SHALL BE IMPLEMENTED UPON COMPLETION ON BASE ASPHALT TO THE SATISFACTION OF THE MUNICIPALITY. THIS SHALL BE THE RESPONSIBILITY OF THE DEVELOPER UNTIL ASSUMPTION.

TOPOGRAPHIC SURVEY PROVIDED BY RPE SURVEYING LTD, MAY 2017

REVISIONS				
No.	DESCRIPTION	DATE	BY	APPROVED
1.	ISSUED FOR SITE PLAN APPLICATION - 2ND SUBMISSION	OCT 14/22	P.G.	
2.	ISSUED FOR SITE PLAN APPLICATION - 3RD SUBMISSION	JAN 20/23	P.G.	
3.	ISSUED FOR SITE PLAN APPLICATION - 4TH SUBMISSION	JUN 28/23	P.G.	

SCS consulting group ltd
 30 CENTURIAN DRIVE, SUITE 100
 MARKHAM, ONTARIO L3R 8B8
 TEL: (905) 475-1900
 FAX: (905) 475-8335

OAKVILLE
 1225 TRAFALGAR ROAD
 OAKVILLE, ONTARIO L6H 0H3
 TEL: (905) 845-6601
 FAX: (905) 815-2025

3171 LAKESHORE ROAD WEST, OAKVILLE
 EROSION AND SEDIMENT CONTROL - STAGE 2, 3 AND 4 EARTHWORKS, SITE SERVICING, AND HOUSING CONSTRUCTION

DATE: JUNE 2023 DESIGNED BY: N.D.M. CHECKED BY: P.G.
 SCALE: 1:250 DRAWN BY: S.T. CHECKED BY: P.G.

PROJECT No: **1930**
 DRAWING No: **ESC-2**

Professional Engineer
 N. D. MCINTOSH
 100230564
 June 28, 2023
 PROVINCE OF ONTARIO

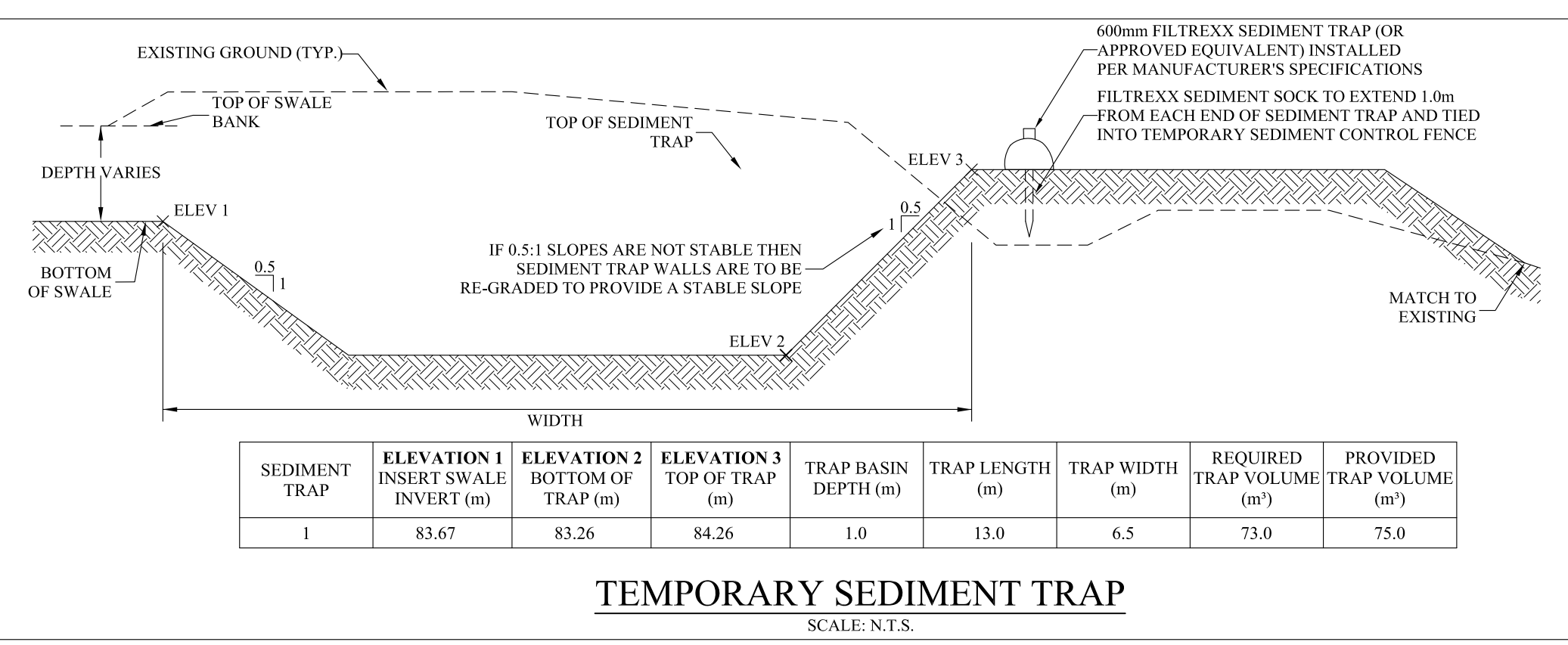
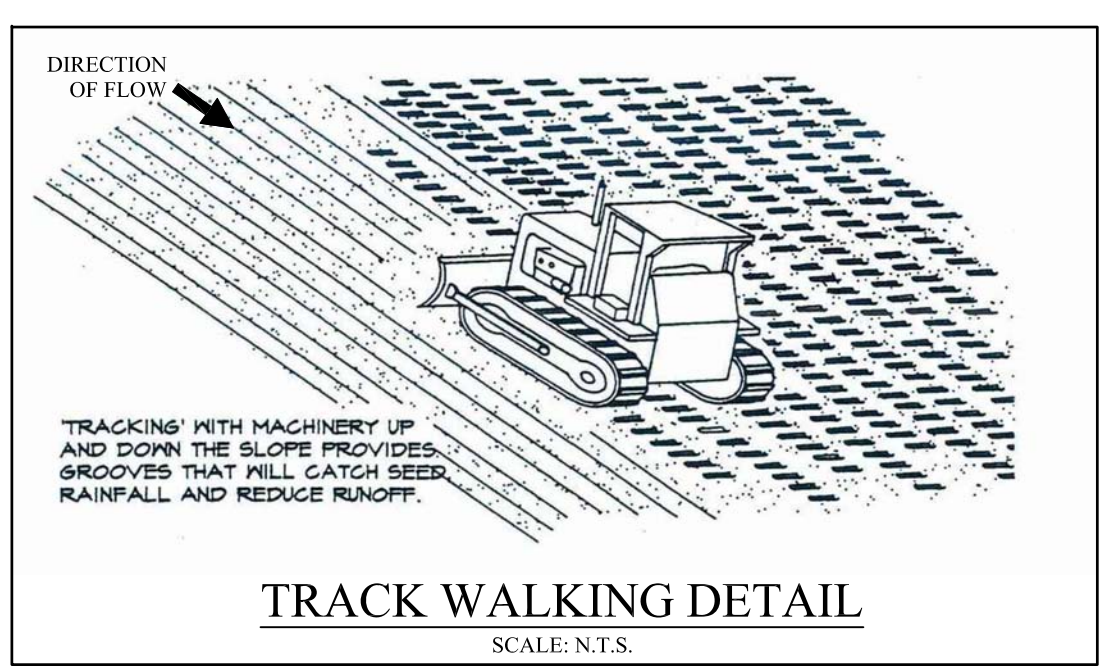
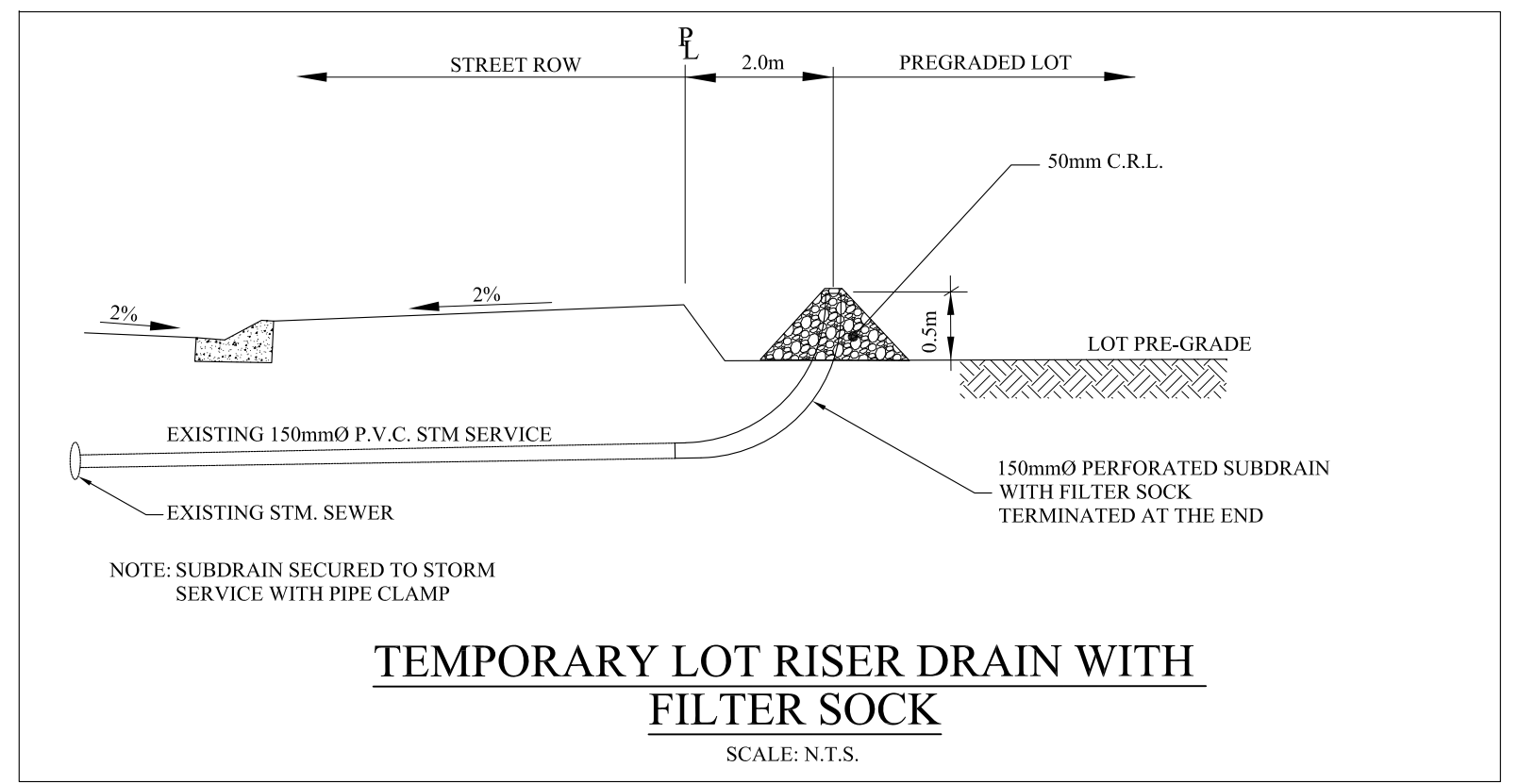
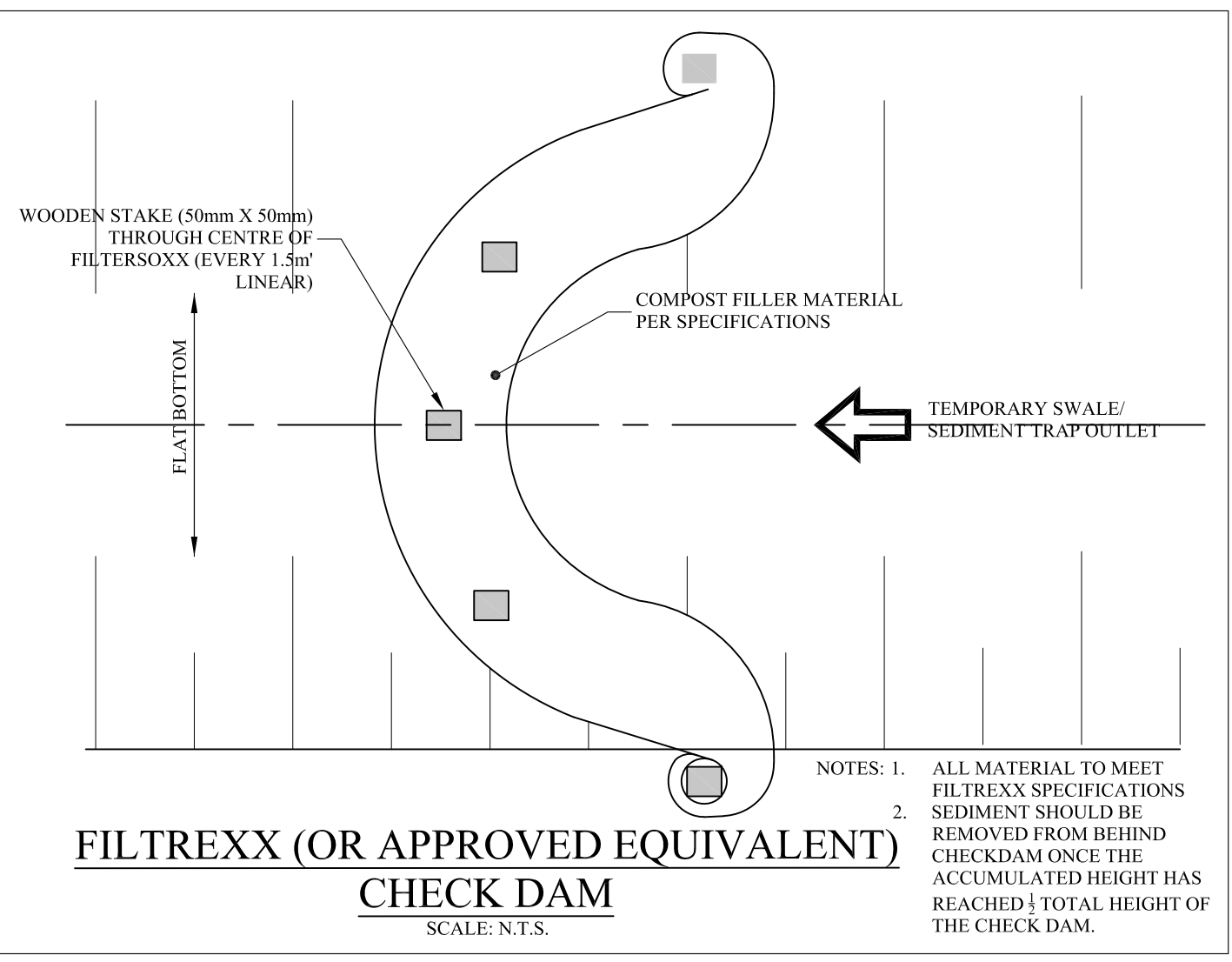
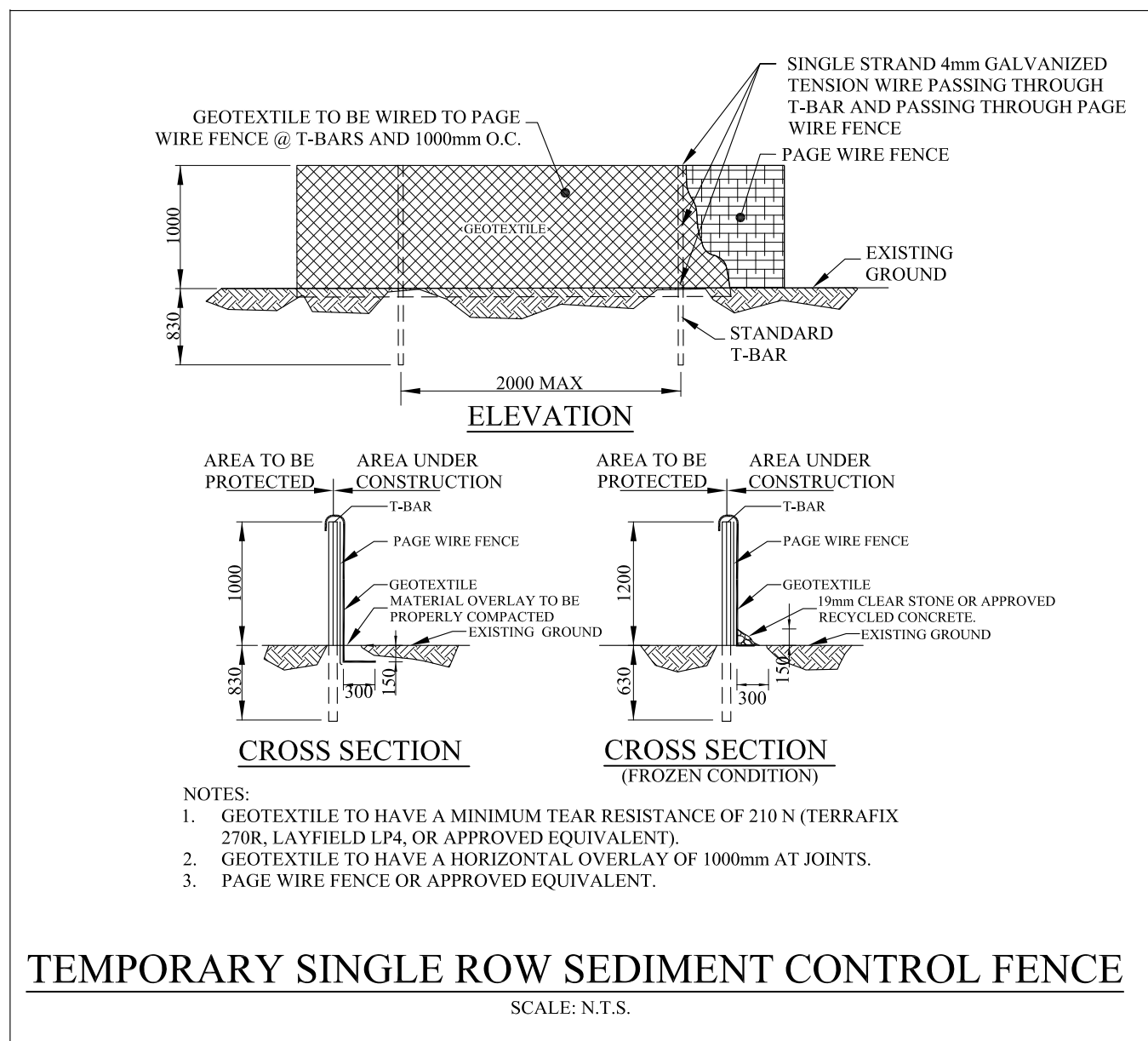
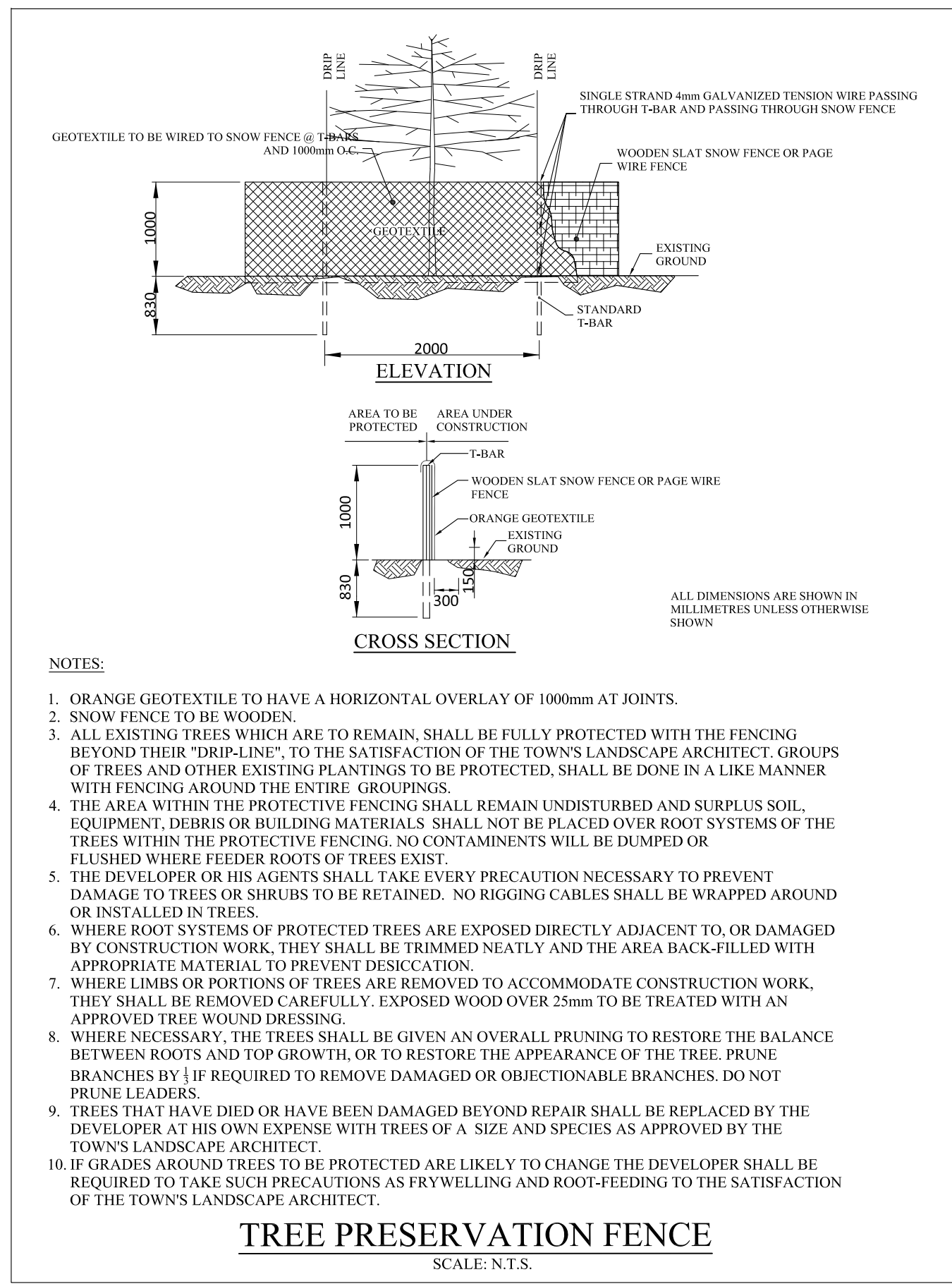
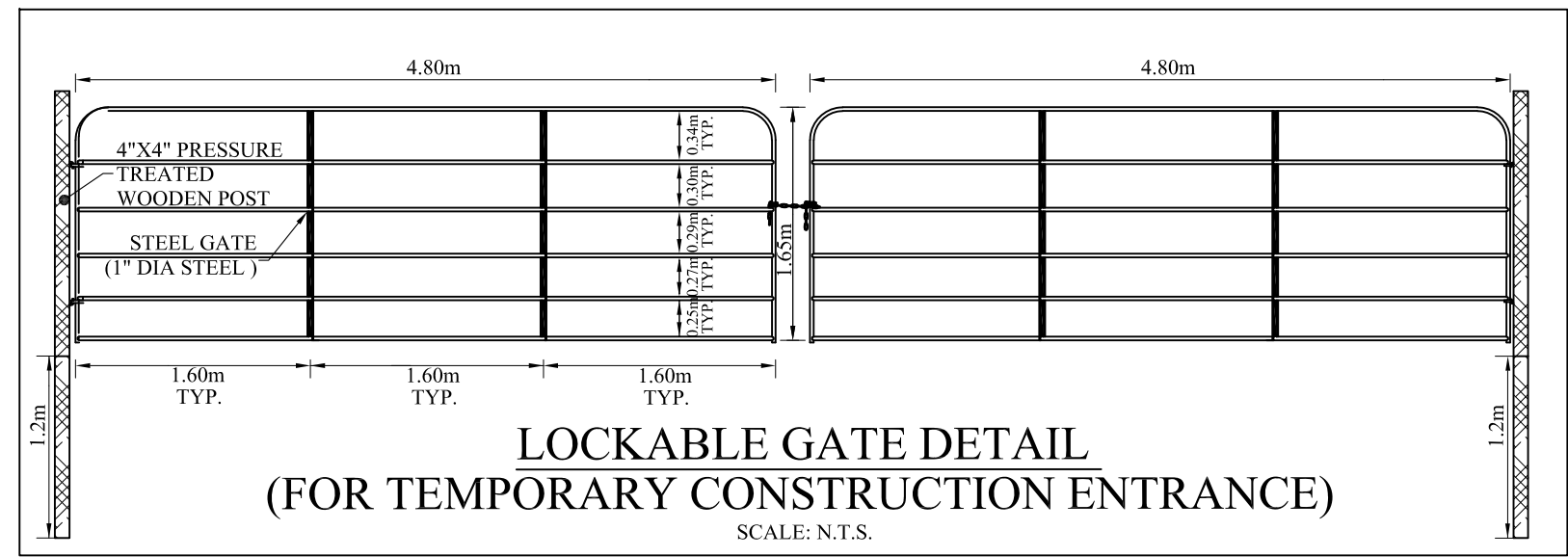
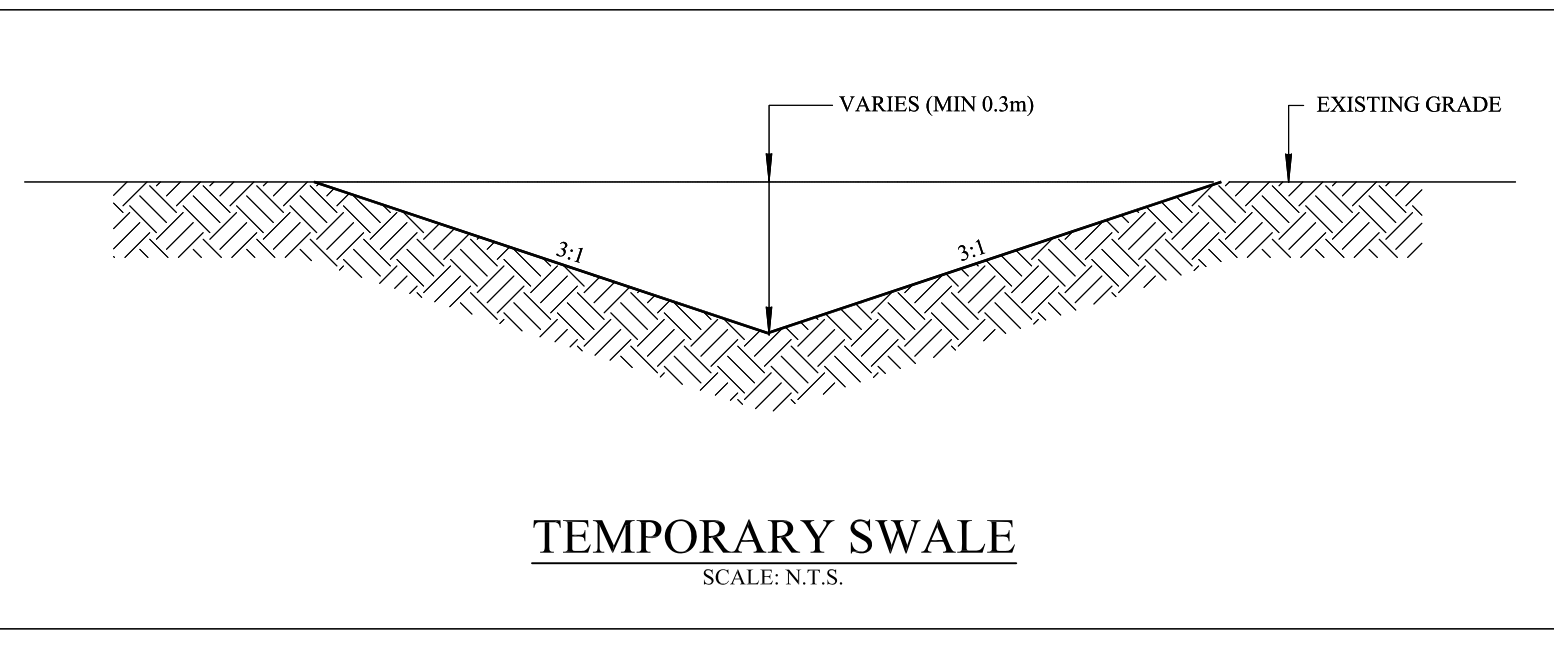
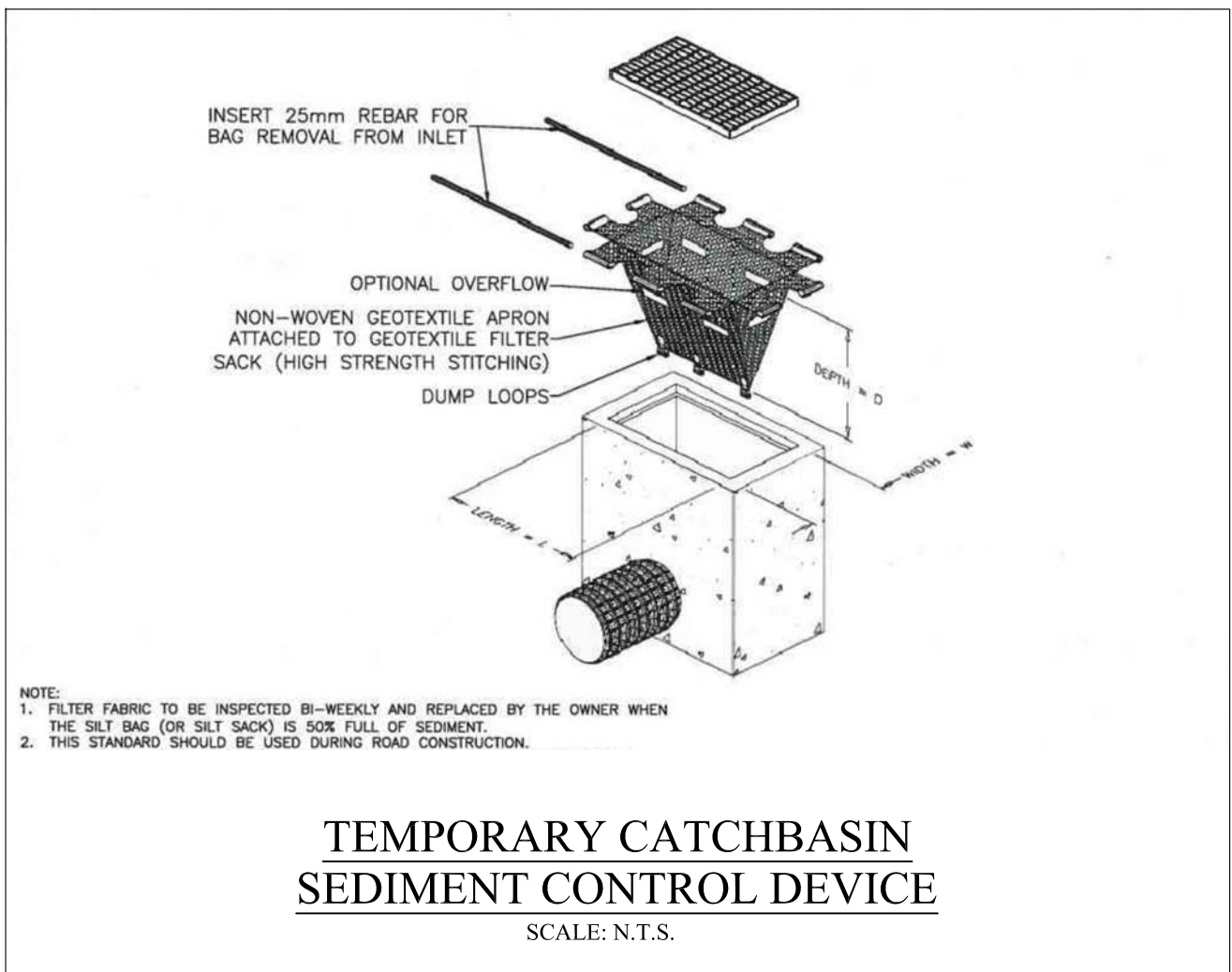
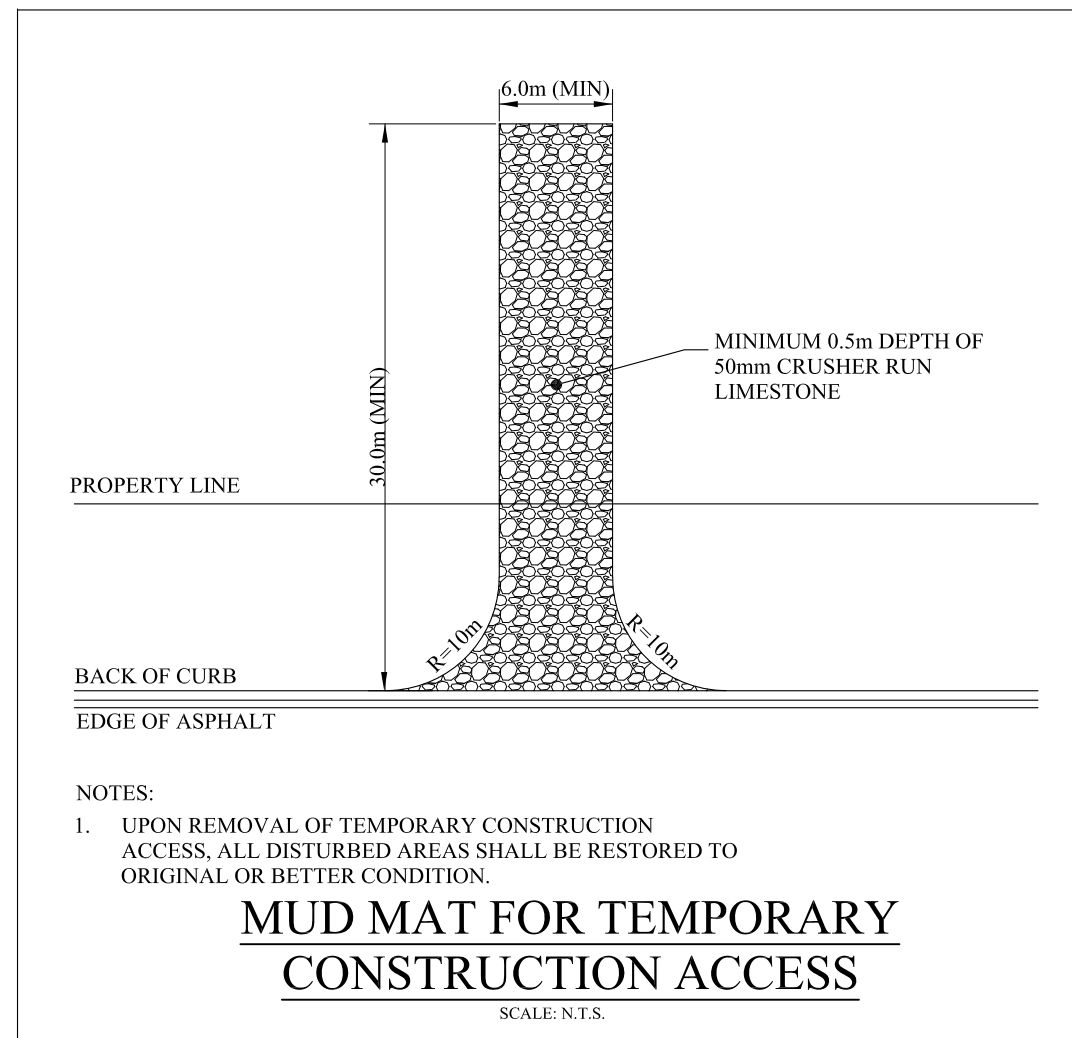

REVISIONS				
No.	DESCRIPTION	DATE	BY	APPROVED
1.	FIRST SUBMISSION	APR 28/23	K.L.	P.G.
2.	ISSUED FOR SITE PLAN APPLICATION - 2nd SUBMISSION	OCT 14/23	K.L.	P.G.
3.	ISSUED FOR SITE PLAN APPLICATION - 3rd SUBMISSION	JAN 20/23	K.L.	P.G.
4.	ISSUED FOR SITE PLAN APPLICATION - 4th SUBMISSION	JUN 28/23	K.L.	P.G.

scs consulting group ltd
30 CENTURIAN DRIVE, SUITE 100
MARKHAM, ONTARIO L3R 8B8
TEL: (905) 475-1900
FAX: (905) 475-9335

3171 LAKESHORE ROAD WEST, OAKVILLE

EROSION AND SEDIMENT CONTROL DETAILS PLAN 1

DATE: JUNE 2023 DESIGNED BY: K.L. CHECKED BY: P.G.
SCALE: N.T.S. DRAWN BY: K.L. CHECKED BY: P.G.

PROJECT No: **1930**
DRAWING No: **ESC-3**

LICENCED PROFESSIONAL ENGINEER
N. D. MCINTOSH
100230564
June 28, 2023
PROVINCE OF ONTARIO

GENERAL

- PRIOR TO STARTING ANY WORKS, THE CONTRACTOR MUST ENSURE THAT ALL NECESSARY APPROVALS ARE IN PLACE FROM THE MUNICIPALITY AND OTHER EXTERNAL AGENCIES, AS REQUIRED.
- WORK SHALL BE CARRIED OUT IN COMPLIANCE WITH THE APPLICABLE HEALTH AND SAFETY ACT AND REGULATIONS FOR CONSTRUCTION PROJECTS.
- WORKS AND MATERIALS SHALL CONFORM TO CURRENT MINISTRY OF THE ENVIRONMENT, CONSERVATION AND PARKS, MUNICIPAL, REGIONAL, ONTARIO PROVINCIAL STANDARDS AND SPECIFICATIONS. FOR ALL WORK WITHIN PRIVATE PROPERTY, WORKS AND MATERIALS SHALL CONFORM TO THE ONTARIO BUILDING CODE, OR THE ABOVE-NOTED STANDARDS, WHICHEVER IS MORE STRINGENT.
- WORKS BY OTHERS (EITHER ON-SITE OR OFF-SITE) MAY BE ON-GOING DURING THE PERIOD OF THIS CONTRACT. COORDINATE CONSTRUCTION ACTIVITIES WITH ALL OTHER CONTRACTORS TO PREVENT CONSTRUCTION CONFLICTS.
- VERIFY THE LOCATION, DIMENSIONS AND ELEVATION OF EXISTING SERVICES AND UTILITIES PRIOR TO CONSTRUCTION. EXISTING INFRASTRUCTURE TO BE PROTECTED AND/OR SUPPORTED DURING CONSTRUCTION. DISCREPANCIES BETWEEN THE DRAWINGS AND FIELD CONDITIONS TO BE IMMEDIATELY REPORTED TO THE ENGINEER.
- REFER TO THE ARCHITECTURAL SITE PLAN FOR DIMENSIONS AND LAYOUT INFORMATION.

WATERMAINS

- PIPE: POLYVINYL CHLORIDE (PVC) CLASS 150 DR-18 PIPE, AWWA C900 AND CSA B137.3, LATEST AMENDMENTS. TYPE C COPPER, ASTM B88.
- EMBEDMENT AND TRENCH DETAIL: OPSD 802.010.
- BEDDING MATERIAL: MUNICIPAL WATERMAIN BEDDING SHALL CONFORM TO MUNICIPAL STANDARDS. PRIVATE WATERMAIN BEDDING SHALL CONFORM TO GEOTECHNICAL RECOMMENDATION.
- MINIMUM COVER: 1.80 m FROM PROPOSED FINISHED GRADES.
- INSULATION: TO BE PROVIDED IF COVER TO OBVERT IS LESS THAN 1.20 METRES. 50mm THICK HIGH LOAD 60. WIDTH AS NOTED ON DRAWING.
- MINIMUM CURVATURE OF PIPE DEFLECTION (IF REQUIRED) SHALL BE AS PER THE FOLLOWING GUIDELINES: 100mm - R=30.0m; 150mm - R=43.0m; 200mm - R=57.0m; 300mm - R=83.0m; 400mm - R=100.0m.
- HORIZONTAL SEPARATION: MINIMUM 2.5 METRES FROM SEWERS AND SEWER MANHOLES, MEASURED FROM THE NEAREST EDGES.
- VERTICAL SEPARATION: MINIMUM 0.5 METRES. IF WATERMAIN MUST CROSS BELOW A SEWER, THE WATERMAIN SHALL BE INSTALLED WITH JOINTS LOCATED A MINIMUM OF 2.5 METRES FROM THE POINT OF CROSSING.
- MECHANICAL RESTRAINTS: REQUIRED AT ALL CHANGES IN PIPE DIRECTION AND AT REDUCERS. RESTRAIN PIPE 2.2 METRES BACK FROM STUBS AND 1.1 METRES ON EITHER SIDE OF VALVES 100mm OR LARGER. RESTRAIN ALL JOINTS WITHIN ENGINEERED FILL AREAS. RESTRAIN RODS AND INSTALLATION SHALL CONFORM TO NFPA 24 STANDARD FOR THE INSTALLATION OF PRIVATE FIRE SERVICE MAINS AND THEIR APPURTENANCES.
- THRUST BLOCKING: REQUIRED FOR ALL TEES, PLUGS AND HORIZONTAL BENDS PER OPSD 1103.010 AND ONTARIO BUILDING CODE S.7.3.4.9.
- HYDRANTS: SHALL CONFORM TO MUNICIPAL SPECIFICATIONS AND STANDARDS. STORZ NOZZLE TO BE ORIENTED PERPENDICULAR TO THE FIRE ROUTE. HYDRANT FLANGE ELEVATION TO BE 0.15m ABOVE PROPOSED FINISHED GRADE AT THE HYDRANT. HYDRANT TO BE PAINTED PER FIRE DEPARTMENT SPECIFICATIONS.
- HYDRANT ANCHOR TEES: ATTACH HYDRANT VALVE TO THE ANCHOR TEE, PROVIDED THAT THE MAXIMUM DISTANCE FROM HYDRANT TO VALVE DOES NOT EXCEED 6.1 METRES. ENSURE VALVE BOX DOES NOT CONFLICT WITH CURBS.
- HYDRANT FLOW TEST: TO BE COMPLETED BY CONTRACTOR PER NFPA AND RESULTS PROVIDED TO THE ENGINEER.
- PIPE FITTINGS: CAST IRON, CEMENT LINED, MECHANICAL JOINT, SHORT BODY CONFORMING TO ANS/AWWA C110/A21.10. JOINTS: RUBBER GASKET CONFORMING TO ANS/AWWA C111/A21.11.
- VALVE BOXES: 100mm SLIDING TYPE BOX COMPLETE WITH GUIDE PLATE. INSTALL EXTENSION STEM AS REQUIRED TO MAINTAIN A MAXIMUM DISTANCE OF 1.8m FROM TOP OF OPERATING NUT TO FINISHED GRADE.
- TRACER WIRE: #12 AWG SOLID COPPER SUITABLE FOR DIRECT BURIAL.
- CATHODIC PROTECTION: OPSD 1109.011 AND OPSD 702. DUCTILE IRON FITTINGS: 5.4 kg ZINC ANODE. HYDRANTS, VALVES AND TEES: 10.8 kg ZINC ANODE. WHERE NEW WATERMAIN IS CONNECTED TO EXISTING CAST IRON OR DUCTILE IRON WATERMAIN, ONE 14.5 kg MAGNESIUM ANODE SHALL BE PLACED ON EACH SIDE OF THE CONNECTION.
- TERMINATE SERVICES 1.0 METRE FROM THE OUTSIDE FACE OF BUILDING, UNLESS OTHERWISE NOTED ON DRAWING. TERMINATE STUBS WITH A PLUG AND 50 mm BLOW OFF.
- ISOLATE NEW WATERMAIN FROM EXISTING LINES IN ORDER TO ALLOW INDEPENDENT PRESSURE TESTING AND CHLORINATION.
- PRESSURE AND BACTERIOLOGICAL TESTING: AS PER MUNICIPAL STANDARD SPECIFICATIONS, ONTARIO BUILDING CODE AND MINISTRY OF THE ENVIRONMENT. TREAT CHLORINATED WATER TO ACCEPTABLE LEVELS PRIOR TO DISCHARGE.
- SUMP PUMPS: TO BE PROVIDED FOR ALL UNITS (BY BUILDER) AND DISCHARGE TO GRADE OR TO STORM SEWER LATERAL WITH GOOSENECK PER DETAIL ON THIS DRAWING.

STORM AND SANITARY SEWERS

- PIPE: POLYVINYL CHLORIDE (PVC) SEWER PIPES AND FITTINGS SHALL CONFORM TO CSA-B182.2.
- PVC SEWERS (375 mm DIAMETER AND SMALLER): SDR-35, CSA B182.2-LATEST AMENDMENT, UNLESS OTHERWISE SPECIFIED.
- CONCRETE SEWERS (450 mm DIAMETER AND LARGER): CONCRETE (CLASS 65-D), CSA A257.2 OR LATEST AMENDMENT, UNLESS OTHERWISE SPECIFIED.
- PVC PIPE SEWER BEDDING: OPSD 802.010.
- CONCRETE PIPE SEWER BEDDING: OPSD 802.030 CLASS 'B' FOR TYPE 1 AND 2 SOILS. OPSD 802.031 FOR TYPE 3 SOILS. SOIL TYPE TO BE CONFIRMED BY THE GEOTECHNICAL CONSULTANT DURING EXCAVATION.
- TRENCH BACKFILL: PER THE SPECIFICATIONS PROVIDED IN THE GEOTECHNICAL REPORT, OR LATEST AMENDMENT THEREOF.
- INSULATION: TO BE PROVIDED IF COVER TO OBVERT IS LESS THAN 1.20 METRES. 50mm THICK HIGH LOAD 60. WIDTH AS NOTED ON DRAWING.
- MANHOLES: OPSD 701.010 TO 701.015 AND CSA A257.4.
- CLEANOUTS: ZURN Z1474 OR APPROVED EQUIVALENT.
- SAFETY PLATFORM: OPSD 404.020 TO OPSD 404.022. INSTALL SAFETY PLATFORM WHERE MANHOLE DEPTH EXCEEDS 5.0m.
- MANHOLE FRAMES AND COVERS: OPSD 401.010 - TYPE 'A'
- JOINTS-PIPE AND MANHOLE: CSA A257.3.
- BACKFILL: ALL MANHOLE AND CATCHBASIN EXCAVATIONS SHALL BE BACKFILLED WITH GRANULAR 'B'.
- MANHOLE BENCHING: OPSD 701.021. CATCHBASIN MANHOLES TO BE BENCHED.
- CATCHBASINS: SINGLE: OPSD 705.010 AND CSA A257.4; DOUBLE: OPSD 705.030 AND CSA A257.4. DITCH INLET CATCHBASINS: OPSD 705.030.

- CATCHBASIN FRAMES AND COVERS: OPSD 400.020.
- CATCHBASIN LEADS AND SERVICE LATERALS ON PRIVATE PROPERTY SHALL BE CONNECTED TO MAINLINE SEWER WITH WYE FITTING.
- DURING CONSTRUCTION ALL CATCHBASINS SHALL BE EQUIPPED WITH TEMPORARY SEDIMENT CONTROL DEVICE. REFER TO DETAILS ON THIS DRAWING.
- CONCRETE ADJUSTMENT UNITS FOR MANHOLES AND CATCHBASINS: OPSD 704.010, OPS5 407 AND CSA A257.4. MAXIMUM HEIGHT OF ADJUSTMENT UNITS SHALL BE 300mm.
- PERFORATED SUB-DRAINS SHALL BE CONNECTED TO ALL CATCHBASIN AND CATCHBASIN MANHOLES AS PER DETAIL ON THIS DRAWING. PERFORATED SUB-DRAINS SHALL BE PLACED UNDER ALL CURB.
- LASER ALIGNMENT AND ELEVATION CONTROL TO BE UTILIZED FOR SEWER INSTALLATIONS.
- FLUSH AND INSPECT SEWERS VIA CCTV CAMERA. SUBMIT ONE WRITTEN REPORT AND TWO DIGITAL VIDEOS IN AN MPEG FORMAT TO THE ENGINEER FOR REVIEW.
- LATERAL SEWER PIPES: SINGLE: 125mm PVC (SDR-28) CSA B181.2; DUAL: 150mm PVC (SDR-28).
- THE CONTRACTOR SHALL PROVIDE TO THE ENGINEER AN AS-CONSTRUCTED SERVICING DRAWING.

GRADING NOTES

- PRIOR TO COMMENCEMENT OF EARTHWORKS, SITE ALTERATION PLANS MUST BE APPROVED AND ALL EROSION AND SEDIMENT CONTROL MEASURES SHALL BE INSTALLED AND OPERATIONAL. THE CONTRACTOR SHALL MAINTAIN ALL WORKS UNTIL CONSTRUCTION IS COMPLETED TO THE SATISFACTION OF THE ENGINEER.
- ENGINEERED FILL SHALL CONFORM TO THE SPECIFICATIONS PROVIDED IN THE GEOTECHNICAL REPORT, OR LATEST AMENDMENT THEREOF.
- ENGINEERED FILL SHALL BE INSPECTED AND TESTED BY THE GEOTECHNICAL CONSULTANT. PROOF ROLLING OF SUBGRADE WILL BE REQUIRED PRIOR TO PLACEMENT OF GRANULAR MATERIALS. COORDINATE INSPECTIONS WITH GEOTECHNICAL CONSULTANT.
- GRANULAR COMPACTION: PER THE SPECIFICATIONS PROVIDED IN THE GEOTECHNICAL REPORT, OR LATEST AMENDMENT THEREOF.
- PAVEMENT STRUCTURE:
40 mm H/L TOP COURSE ASPHALT
60 mm H/L BASE COURSE ASPHALT
150 mm GRANULAR 'A'
350 mm GRANULAR 'B'
- ASPHALT COMPACTION: PER THE SPECIFICATIONS PROVIDED IN THE GEOTECHNICAL REPORT, OR LATEST AMENDMENT THEREOF.
- BARRIER CURB: OPSD 600.110.
CONCRETE BARRIER CURB AND GUTTER (TWO STAGE CONSTRUCTION) : OPSD 600.070
- CONCRETE SIDEWALK: 125mm DEEP WITH 125mm GRANULAR 'A' BASE CONCRETE SIDEWALK ACROSS RESIDENTIAL DRIVEWAY: 175mm DEEP. CONCRETE SIDEWALK ACROSS LANEWAYS, ROADS, COMMERCIAL, INDUSTRIAL AND INSTITUTIONAL DRIVEWAYS: 200mm DEEP.
- LAP JOINTS SHALL BE USED WHERE PROPOSED ASPHALT MEETS EXISTING ASPHALT AS PER DETAIL ON THIS DRAWING.
- INSTALL SIGNAGE AS PER THE ARCHITECTURAL SITE PLAN.
- ALL EXCESS EXCAVATED MATERIAL SHALL BE REMOVED OFFSITE TO THE CONTRACTOR'S APPROVED DISPOSAL SITE.
- EMBANKMENTS SHALL BE SLOPED AT A MAXIMUM OF 3H:1V, UNLESS OTHERWISE SPECIFIED.
- DISTURBED AREAS SHALL BE RESTORED TO ORIGINAL CONDITION OR BETTER. THE RELOCATION OR REMOVAL OF TREES AND SHRUBS SHALL BE SUBJECT TO APPROVAL BY THE ARBORIST.
- ALL BOULEVARD TO BE PLACED WITH 300mm TOPSOIL AND SOD.
- REFER TO LANDSCAPE DRAWINGS FOR LOCATION AND TYPE OF ALL HARD LANDSCAPE SURFACES.
- THE CONTRACTOR SHALL PROVIDE TO THE ENGINEER AN AS-CONSTRUCTED GRADING DRAWING.

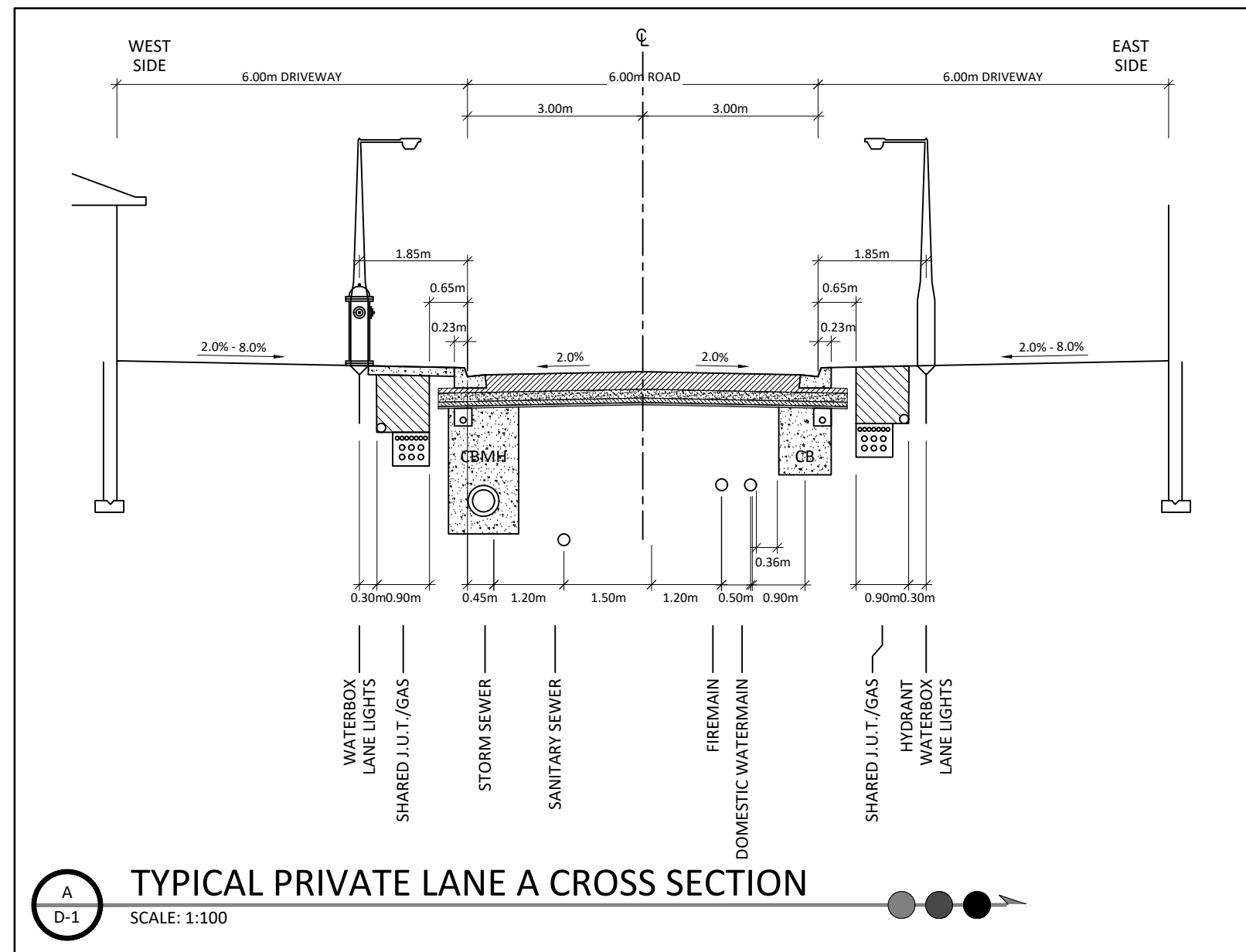

TYPICAL PRIVATE LANE A CROSS SECTION
SCALE: 1:100

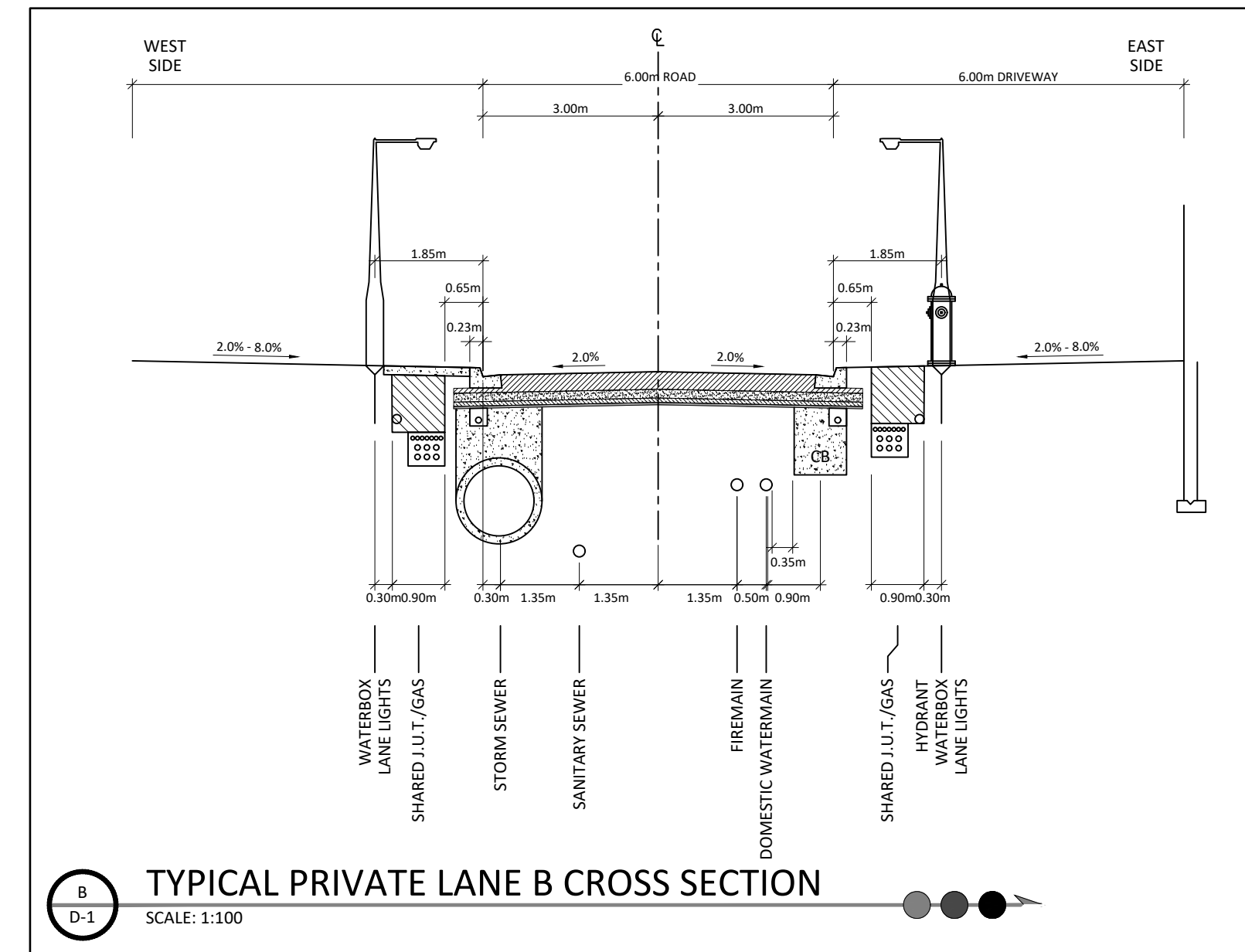

TYPICAL PRIVATE LANE B CROSS SECTION
SCALE: 1:100

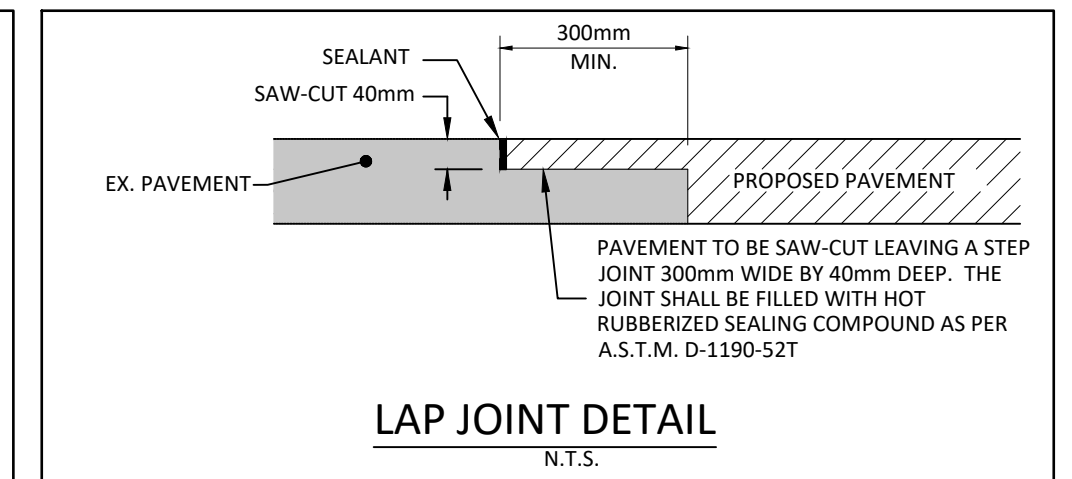

LAP JOINT DETAIL
N.T.S.

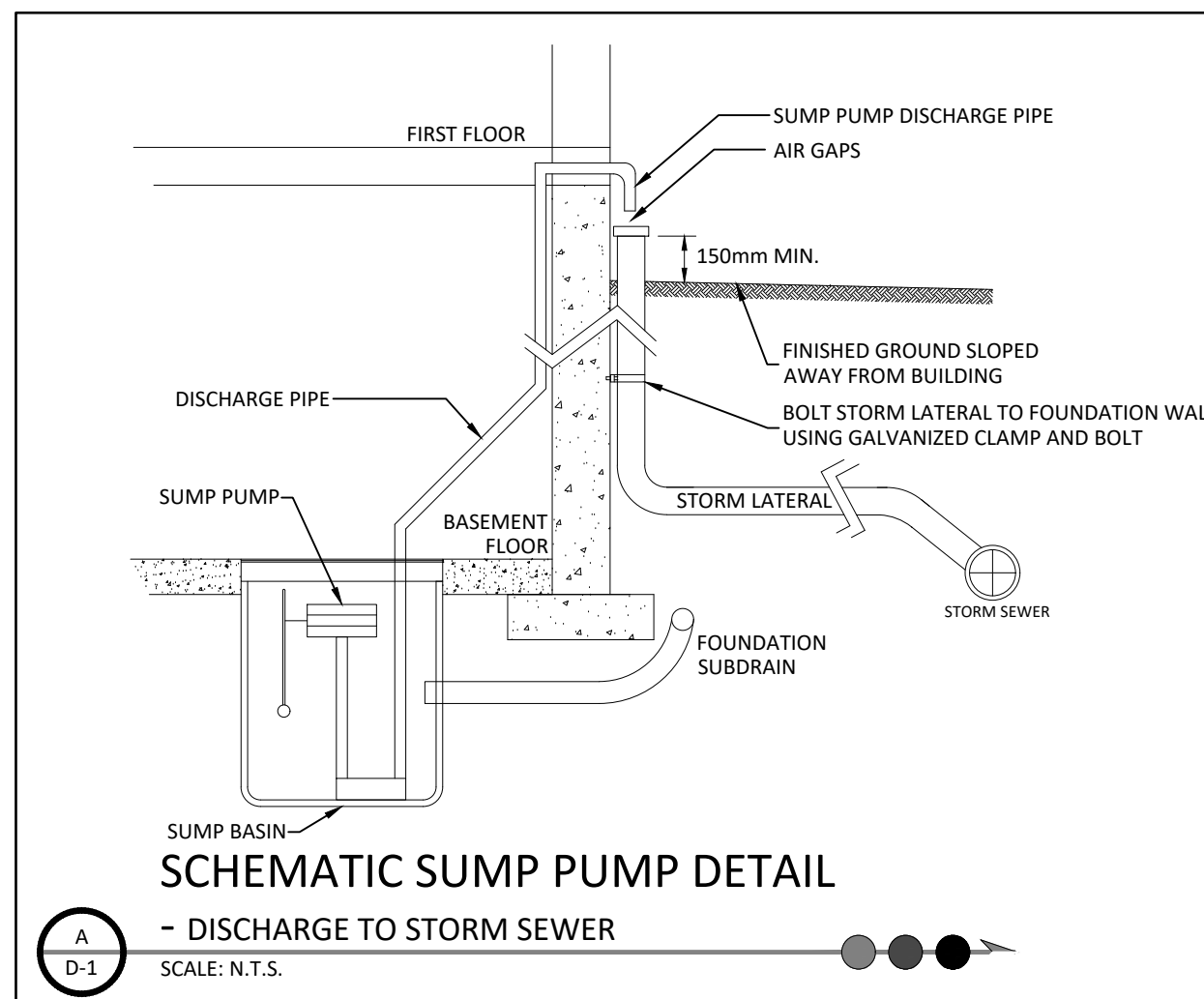

SCHEMATIC SUMP PUMP DETAIL
- DISCHARGE TO STORM SEWER
SCALE: N.T.S.

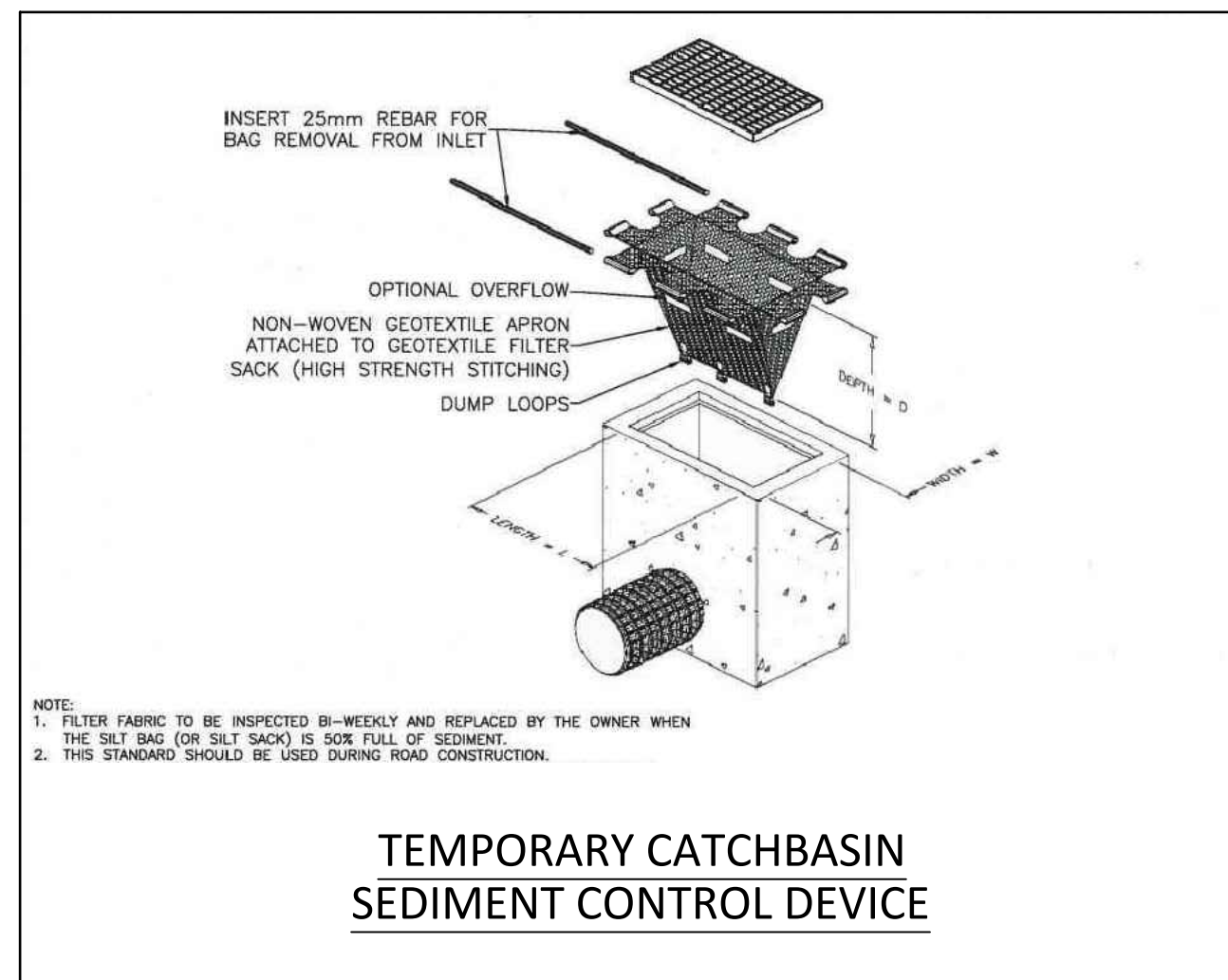

TEMPORARY CATCHBASIN SEDIMENT CONTROL DEVICE

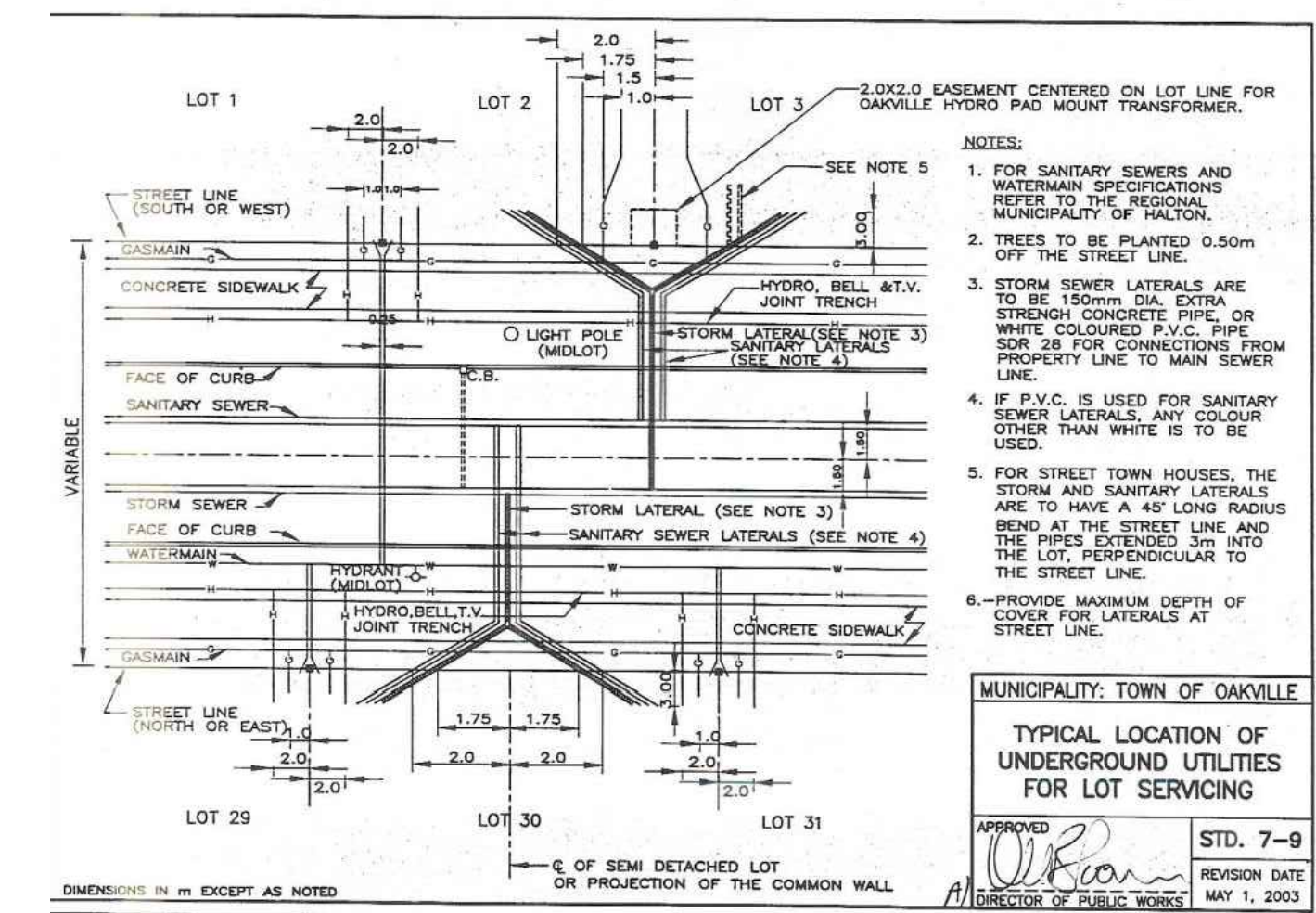

MUNICIPALITY: TOWN OF OAKVILLE
TYPICAL LOCATION OF UNDERGROUND UTILITIES FOR LOT SERVICING
APPROVED: [Signature] STD. 7-9
REVISION DATE: MAY 1, 2003

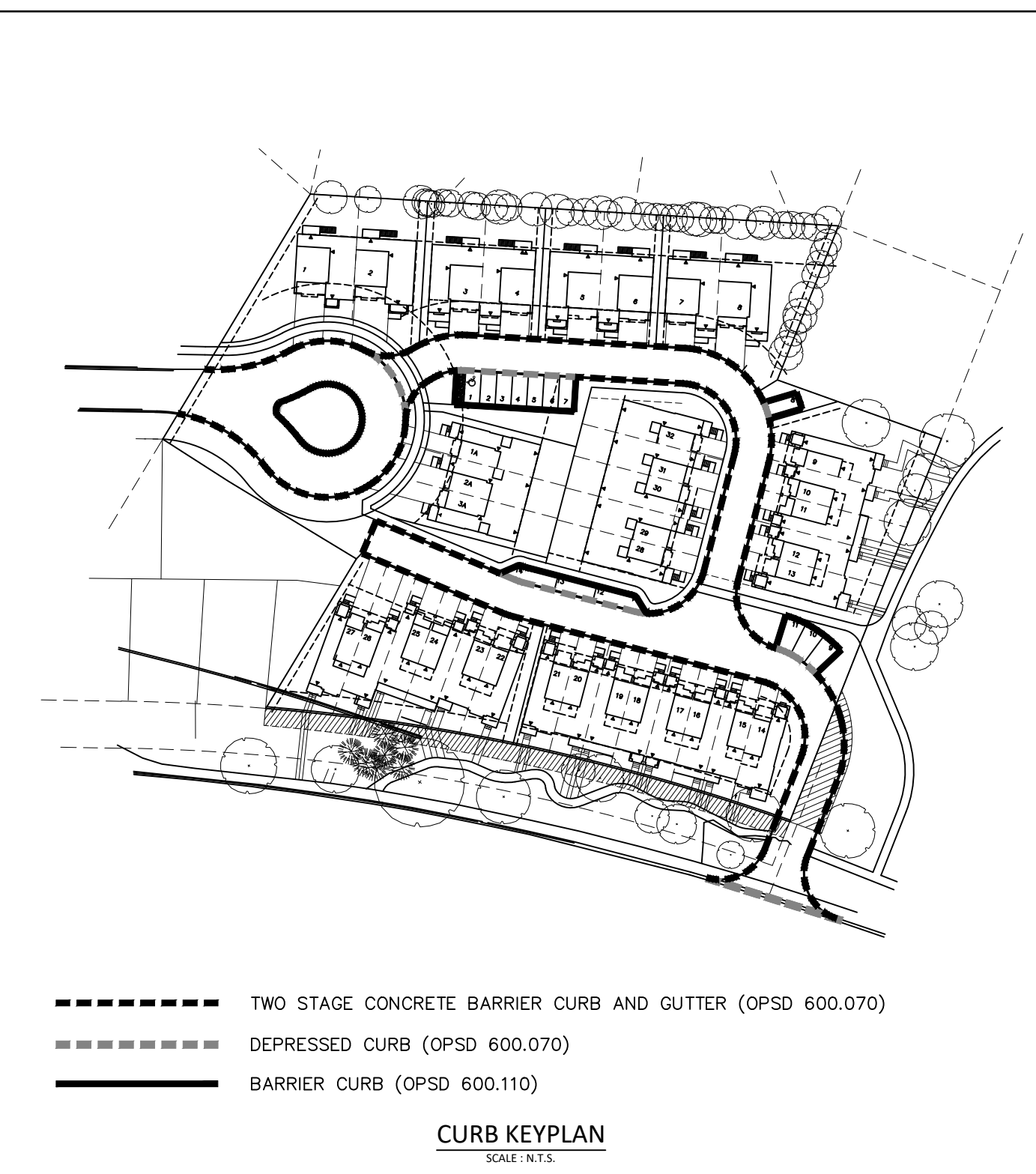

- TWO STAGE CONCRETE BARRIER CURB AND GUTTER (OPSD 600.070)
- DEPRESSED CURB (OPSD 600.070)
- BARRIER CURB (OPSD 600.110)

CURB KEYPLAN
SCALE: N.T.S.

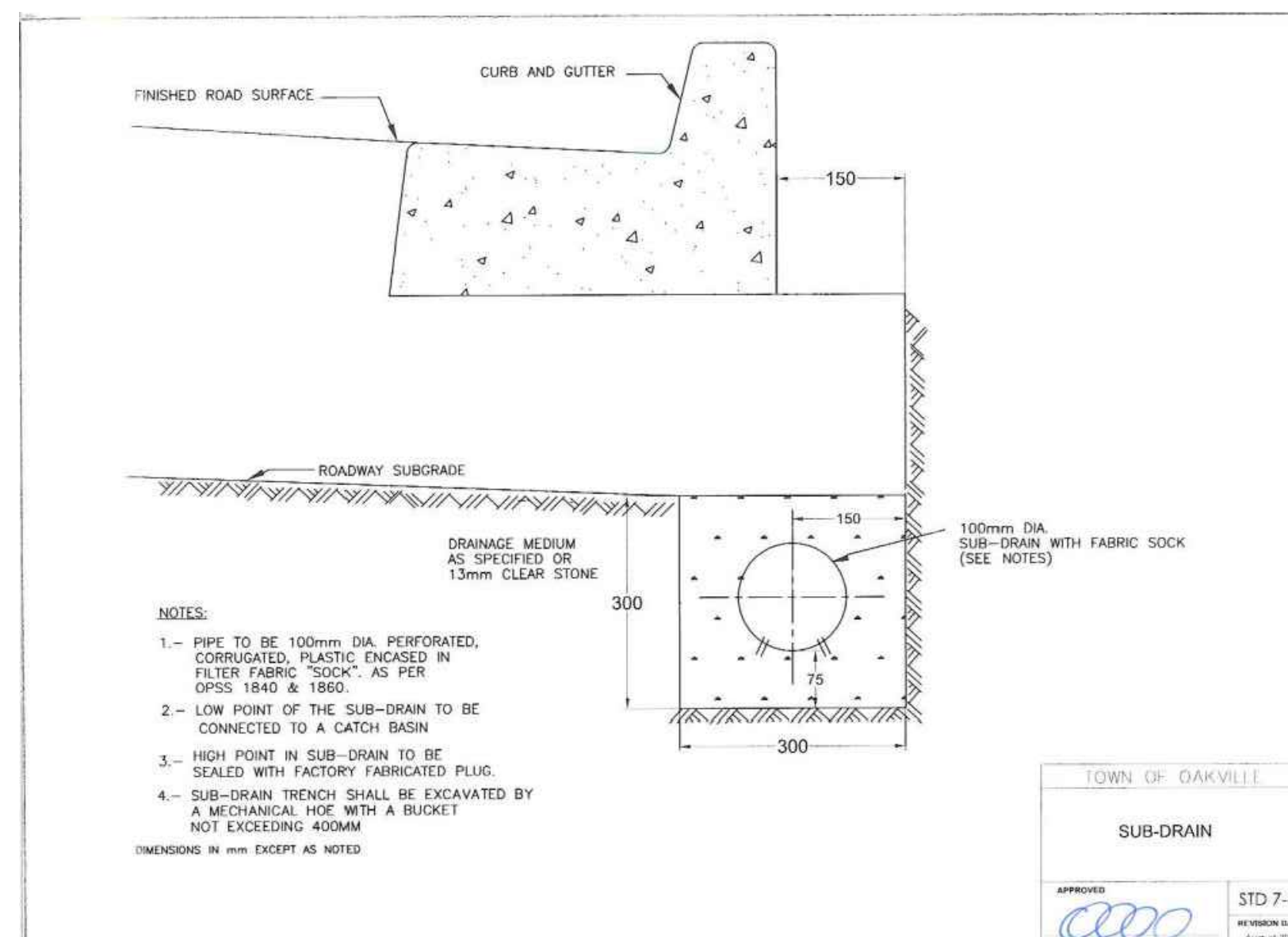

- NOTES:
- PIPE TO BE 100mm DIA. PERFORATED, CORRUGATED, PLASTIC ENCASED IN FILTER FABRIC 'SOCK'. AS PER OPS5 1840 & 1860.
 - LOW POINT OF THE SUB-DRAIN TO BE CONNECTED TO A CATCH BASIN
 - HIGH POINT IN SUB-DRAIN TO BE SEALED WITH FACTORY FABRICATED PLUG.
 - SUB-DRAIN TRENCH SHALL BE EXCAVATED BY A MECHANICAL HOE WITH A BRACKET NOT EXCEEDING 400mm

TOWN OF OAKVILLE
SUB-DRAIN
APPROVED: [Signature] STD 7-60
REVISION DATE: HIGH 2003

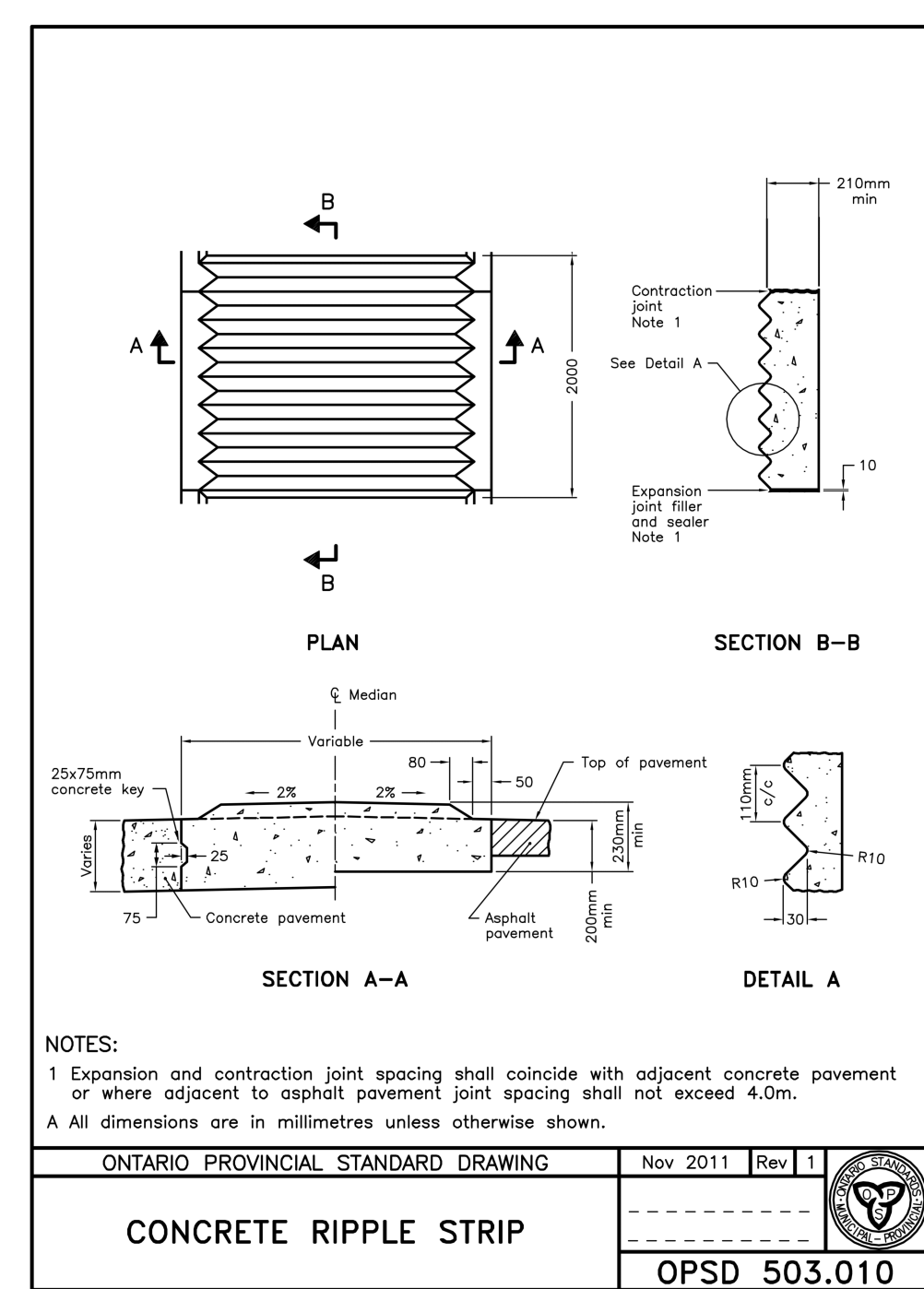

- NOTES:
- Expansion and contraction joint spacing shall coincide with adjacent concrete pavement or where adjacent to asphalt pavement joint spacing shall not exceed 4.0m.
 - All dimensions are in millimetres unless otherwise shown.

CONCRETE RIPPLE STRIP
OPSD 503.010

REVISIONS				
No.	DESCRIPTION	DATE	BY	APPROVED
1.	ISSUED FOR SITE PLAN APPLICATION	JAN 20/22	P.G.	P.G.
2.	ISSUED FOR SITE PLAN APPLICATION - 2nd SUBMISSION	OCT 14/22	P.G.	P.G.
3.	ISSUED FOR SITE PLAN APPLICATION - 3rd SUBMISSION	JAN 20/23	P.G.	P.G.
4.	ISSUED FOR SITE PLAN APPLICATION - 4th SUBMISSION	JUN 28/23	P.G.	P.G.

30 CENTURIAN DRIVE, SUITE 100
MARKHAM, ONTARIO L3R 8B8
TEL: (905) 475-1900
FAX: (905) 475-9335

OAKVILLE

VOGUE WYCLIFFE (OAKVILLE) LIMITED
1225 TRAFALGAR ROAD
OAKVILLE, ONTARIO L6H 0H3
TEL: (905) 845-6601

3171 LAKESHORE ROAD WEST, OAKVILLE

DETAILS PLAN

DATE: JUNE 2023 DESIGNED BY: K.L. CHECKED BY: P.G.
SCALE: N.T.S. DRAWN BY: K.L. CHECKED BY: P.G.

PROJECT No: **1930**
DRAWING No: **D-1**

LICENCED PROFESSIONAL ENGINEER
K. CHEN
100136982
2023-06-28
PROVINCE OF ONTARIO

TANGENT **SUPERELEVATED**

LEGEND:
S - Rate of pavement superelevation in percent, %.

NOTES:
1 When curb and gutter is adjacent to concrete pavement or base, this drawing shall be used in conjunction with OPSD 552.010 and 552.020.
2 Flexible and composite pavement shall be placed 5mm above the adjacent edge of gutter.
3 For slipforming procedure a 5% batter is acceptable.
A Treatment at entrances shall be according to OPSD 351.010.
B Outlet treatment shall be according to the OPSD 610 Series.
C The transition from one curb type to another shall be a minimum length of 3.0m, except in conjunction with guide rail where it shall be according to the OPSD 900 Series.
D All dimensions are in millimetres unless otherwise shown.

ONTARIO PROVINCIAL STANDARD DRAWING Nov 2012 Rev 2
CONCRETE SEMI-MOUNTABLE CURB WITH STANDARD GUTTER
OPSD 600.060

STIRRUP DETAIL **DETAIL AT CATCH BASIN**

NOTES:
1 Flexible and composite pavement shall be placed 5mm above the adjacent edge of gutter.
2 When sidewalk is continuously adjacent, the dropped curb at entrances shall be reduced to 75mm.
3 For slipforming procedure a 5% batter is acceptable.
A Stage I surface shall be cleaned of foreign material prior to placement of Stage II material.
B Treatment at entrances shall be according to OPSD 351.010.
C Outlet treatment shall be according to the OPSD 610 Series.
D The transition from one curb type to another shall be a minimum length of 3.0m, except in conjunction with guide rail, when it shall be according to the OPSD 900 Series.
E All dimensions are in millimetres unless otherwise shown.

ONTARIO PROVINCIAL STANDARD DRAWING Nov 2012 Rev 2
CONCRETE BARRIER CURB WITH STANDARD GUTTER
TWO STAGE CONSTRUCTION
OPSD - 600.070

SUMP DETAIL **ALTERNATIVES**
A PRECAST SLAB BASE **B CAST-IN-PLACE BASE** **C PRECAST FLAT CAP**

NOTES:
1 The sump is measured from the lowest invert.
A Granular backfill shall be placed to a minimum thickness of 300mm all around the maintenance hole.
B Precast concrete components shall be according to OPSD 701.030, 701.031, or 701.032.
C Structure exceeding 5.0m in depth shall include safety platform according to OPSD 404.020.
D Pipe support according to OPSD 708.020.
E For benching and pipe opening details, see OPSD 701.021.
F For adjustment unit and frame installation, see OPSD 704.010.
G All dimensions are nominal.
H All dimensions are in millimetres unless otherwise shown.

ONTARIO PROVINCIAL STANDARD DRAWING Nov 2014 Rev 5
PRECAST CONCRETE MAINTENANCE HOLE
1200mm DIAMETER
OPSD 701.010

Hydrant **Breakable flange** **Valve box** **Drain hole** **Concrete thrust block**

NOTES:
1 All concrete thrust blocks shall be poured against undisturbed ground.
2 When specified, for watermain 400mm and less, locate valve within 1.0m of centreline of watermain. Retaining and restraining devices shall be utilized. For watermain 600mm and over, bolt valve with flanged end directly to flanged tee.
3 Retaining and restraining devices shall be as specified.
A Bond breaker shall be used between the concrete and the fittings and appurtenances.
B Bolts and nuts for buried flange to flange connections shall be stainless steel.
C When required, flange of standpipe extensions shall not be in frost zone.
D This OPSD shall be read in conjunction with OPSD 1103.010 and 1103.020.
E Backfill material within 500mm of service box shall be native or imported, as specified.
F Tracer wire shall be installed as specified.
G All dimensions are in millimetres unless otherwise shown.

ONTARIO PROVINCIAL STANDARD DRAWING Nov 2018 Rev 3
HYDRANT INSTALLATION
OPSD 1105.010

SUMP DETAIL **ALTERNATIVES**
A PRECAST SLAB BASE **B CAST-IN-PLACE BASE** **C PRECAST FLAT CAP**

NOTES:
1 The sump is measured from the lowest invert.
A Granular backfill shall be placed to a minimum thickness of 300mm all around the maintenance hole.
B Precast concrete components shall be according to OPSD 701.030, 701.031, or 701.032.
C Structure exceeding 5.0m in depth shall include safety platform according to OPSD 404.020.
D Pipe support according to OPSD 708.020.
E For benching and pipe opening details, see OPSD 701.021.
F For adjustment unit and frame installation, see OPSD 704.010.
G All dimensions are nominal.
H All dimensions are in millimetres unless otherwise shown.

ONTARIO PROVINCIAL STANDARD DRAWING Nov 2014 Rev 5
PRECAST CONCRETE MAINTENANCE HOLE
1200mm DIAMETER
OPSD 701.010

Maintenance Hole Diameter	No. 7				No. 8	
	No. 1-4	No. 5 and 6	No. 7	Inlet Hole	Outlet Hole	
1200	700	860	780	700	860	
1500	860	1220	960	860	1170	
1800	1220	1485	1220	1220	1485	
2400	1485	2020	1760	1485	2020	
3000	1930	2450	2300	1930	2450	
3600	2470	3085	2730	2470	3085	

NOTES:
1 Slopes shall be maintained from the outlet hole opening for top of benching.
A Concrete for benching shall be 30MPa.
B When benching is hand-finished, it shall be given wood float finish, channel shall be given steel trowel finish.
C Benchings slope and height shall be as specified.
D When specified, maintenance holes that are 1200mm in diameter with a uniform channel for 200 or 250mm pipe may be prebenched at the manufacturer with standardized benching slope and channel orientation.
E All dimensions are nominal.
F All dimensions are in millimetres unless otherwise shown.

ONTARIO PROVINCIAL STANDARD DRAWING Nov 2014 Rev 4
MAINTENANCE HOLE BENCHING AND PIPE OPENING ALTERNATIVES
OPSD 701.021

HORIZONTAL GOOSENECK **VERTICAL GOOSENECK OPTION** **VERTICAL SECTION**

NOTES:
1 For plastic service pipes, install main stop at 15' above horizontal with a minimum 1.2m long gooseneck.
2 Direct tap ductile iron pipe with approved tool with standard AWWA inlet thread.
3 Service connections to plastic watermain shall be made using service saddles or factory made tees.
A When specified, the vertical gooseneck option shall be used.
B Couplings shall not be permitted unless the service length exceeds 20m between the main stop and curb stop.
C All water services shall be installed 90° to the longitudinal axis of the watermain.
D Backfill material within 500mm of service box shall be native or imported, as specified.
E All dimensions are in millimetres unless otherwise shown.

ONTARIO PROVINCIAL STANDARD DRAWING Nov 2018 Rev 4
WATER SERVICE CONNECTION
19 and 25mm DIAMETER SIZES
OPSD 1104.010

FRAME PLAN **SECTION C-C** **SECTION D-D** **TYPE A CLOSED COVER** **TYPE B OPEN COVER**

NOTES:
A Covers shall be Type A or Type B, as specified.
B All dimensions are in millimetres unless otherwise shown.

ONTARIO PROVINCIAL STANDARD DRAWING Nov 2018 Rev 4
CAST IRON, SQUARE FRAME WITH CIRCULAR CLOSED OR OPEN COVER FOR MAINTENANCE HOLES
OPSD 401.010

REVISIONS				
No.	DESCRIPTION	DATE	BY	APPROVED
1.	ISSUED FOR SITE PLAN APPLICATION	JAN 20/22	P.G.	P.G.
2.	ISSUED FOR SITE PLAN APPLICATION - 2nd SUBMISSION	OCT 14/22	P.G.	P.G.
3.	ISSUED FOR SITE PLAN APPLICATION - 3rd SUBMISSION	JAN 20/23	P.G.	P.G.
4.	ISSUED FOR SITE PLAN APPLICATION - 4th SUBMISSION	JUN 28/23	P.G.	P.G.

SCS consulting group Ltd 30 CENTURIAN DRIVE, SUITE 100 MARKHAM, ONTARIO L3R 8B8 TEL: (905) 475-1900 FAX: (905) 475-9335

OAKVILLE 1225 TRAFALGAR ROAD OAKVILLE, ONTARIO L6H 0H3 TEL: (905) 845-6601

VOGUE WYCLIFFE (OAKVILLE) LIMITED
3171 LAKESHORE ROAD WEST, OAKVILLE

DETAILS PLAN

DATE: JUNE 2023 DESIGNED BY: K.L. CHECKED BY: P.G.
SCALE: N.T.S. DRAWN BY: K.L. CHECKED BY: P.G.

PROJECT No: **1930**
DRAWING No: **D-2**

K. CHEN 100136982 2023-06-28
PROVINCE OF ONTARIO

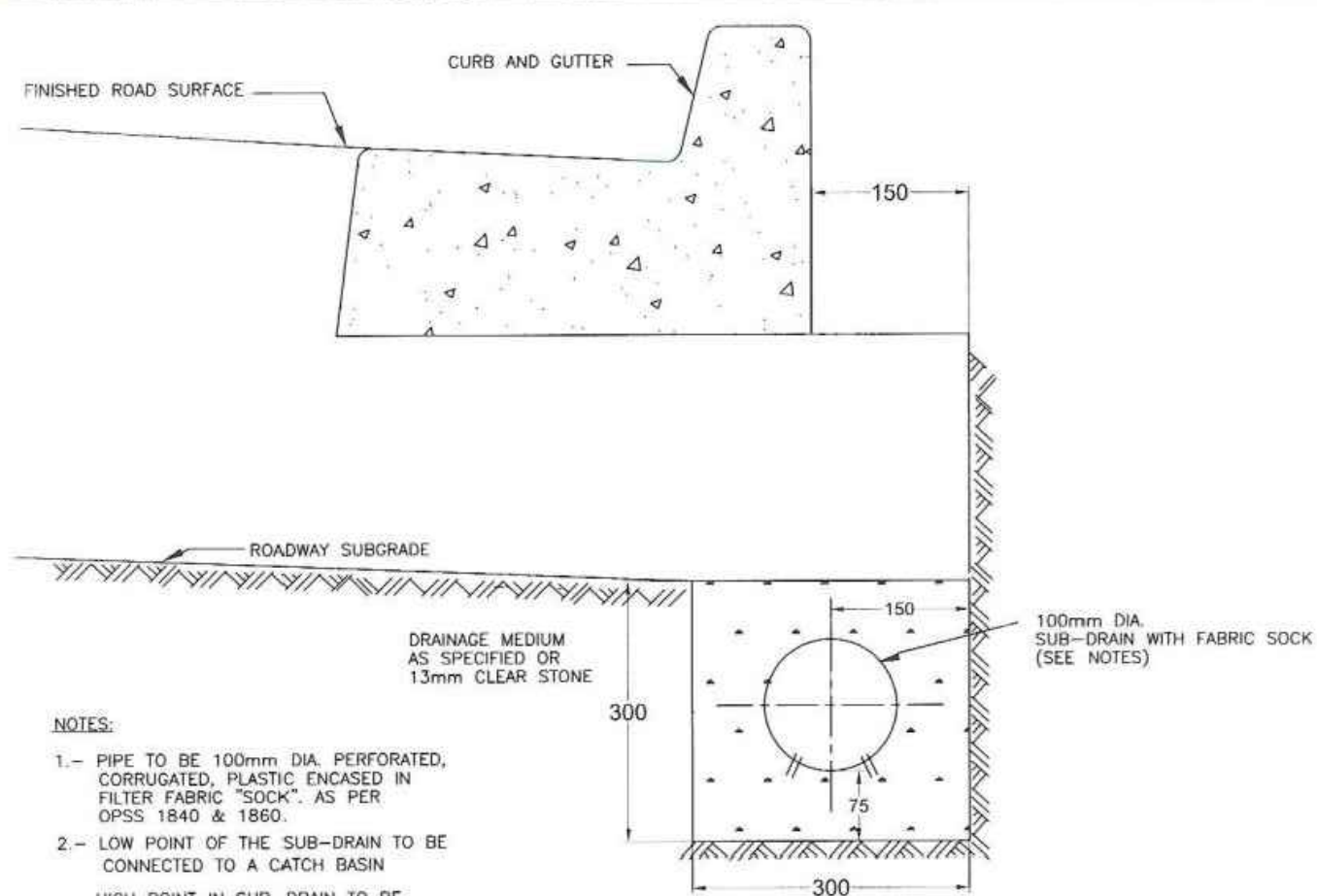

- NOTES:
- 1.- PIPE TO BE 100mm DIA PERFORATED, CORRUGATED, PLASTIC ENCASED IN FILTER FABRIC "SOCK", AS PER CPSS 1840 & 1860.
 - 2.- LOW POINT OF THE SUB-DRAIN TO BE CONNECTED TO A CATCH BASIN
 - 3.- HIGH POINT IN SUB-DRAIN TO BE SEALED WITH FACTORY FABRICATED PLUG.
 - 4.- SUB-DRAIN TRENCH SHALL BE EXCAVATED BY A MECHANICAL HOE WITH A BUCKET NOT EXCEEDING 400MM
- DIMENSIONS IN mm EXCEPT AS NOTED

TOWN OF OAKVILLE

SUB-DRAIN

APPROVED:  STD 7-60
August 2022

REVISIONS				
No.	DESCRIPTION	DATE	BY	APPROVED
1.	ISSUED FOR SITE PLAN APPLICATION	JAN 20/22	P.G.	P.G.
2.	ISSUED FOR SITE PLAN APPLICATION - 2nd SUBMISSION	OCT 14/22	P.G.	P.G.
3.	ISSUED FOR SITE PLAN APPLICATION - 3rd SUBMISSION	JAN 20/23	P.G.	P.G.
4.	ISSUED FOR SITE PLAN APPLICATION - 4th SUBMISSION	JUN 28/23	P.G.	P.G.

 30 CENTURIAN DRIVE, SUITE 100
MARKHAM, ONTARIO L3R 8B8
TEL: (905) 475-1900
FAX: (905) 475-8335

 OAKVILLE 1225 TRAFALGAR ROAD
OAKVILLE, ONTARIO L6H 0H3
TEL: (905) 845-6601

VOGUE WYCLIFFE (OAKVILLE) LIMITED
3171 LAKESHORE ROAD WEST,
OAKVILLE

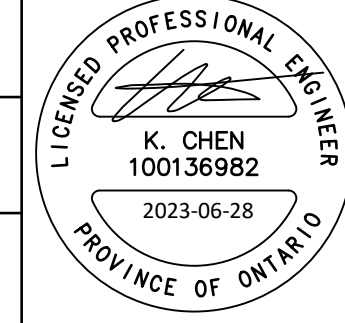
 K. CHEN
100136982
2023-06-28
PROVINCE OF ONTARIO

DETAILS PLAN

DATE: JUNE 2023	DESIGNED BY: K.L.	CHECKED BY: P.G.
SCALE: N.T.S.	DRAWN BY: K.L.	CHECKED BY: P.G.

PROJECT No: 1930
DRAWING No: D-3

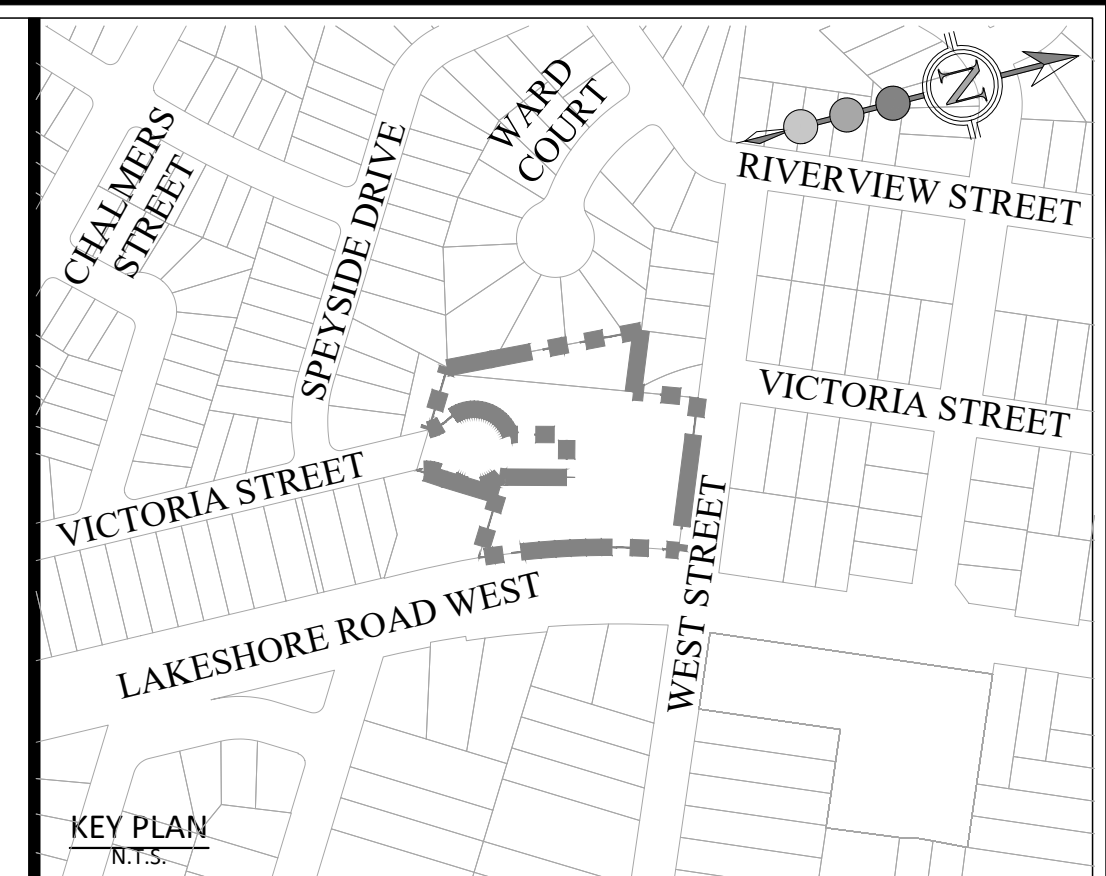
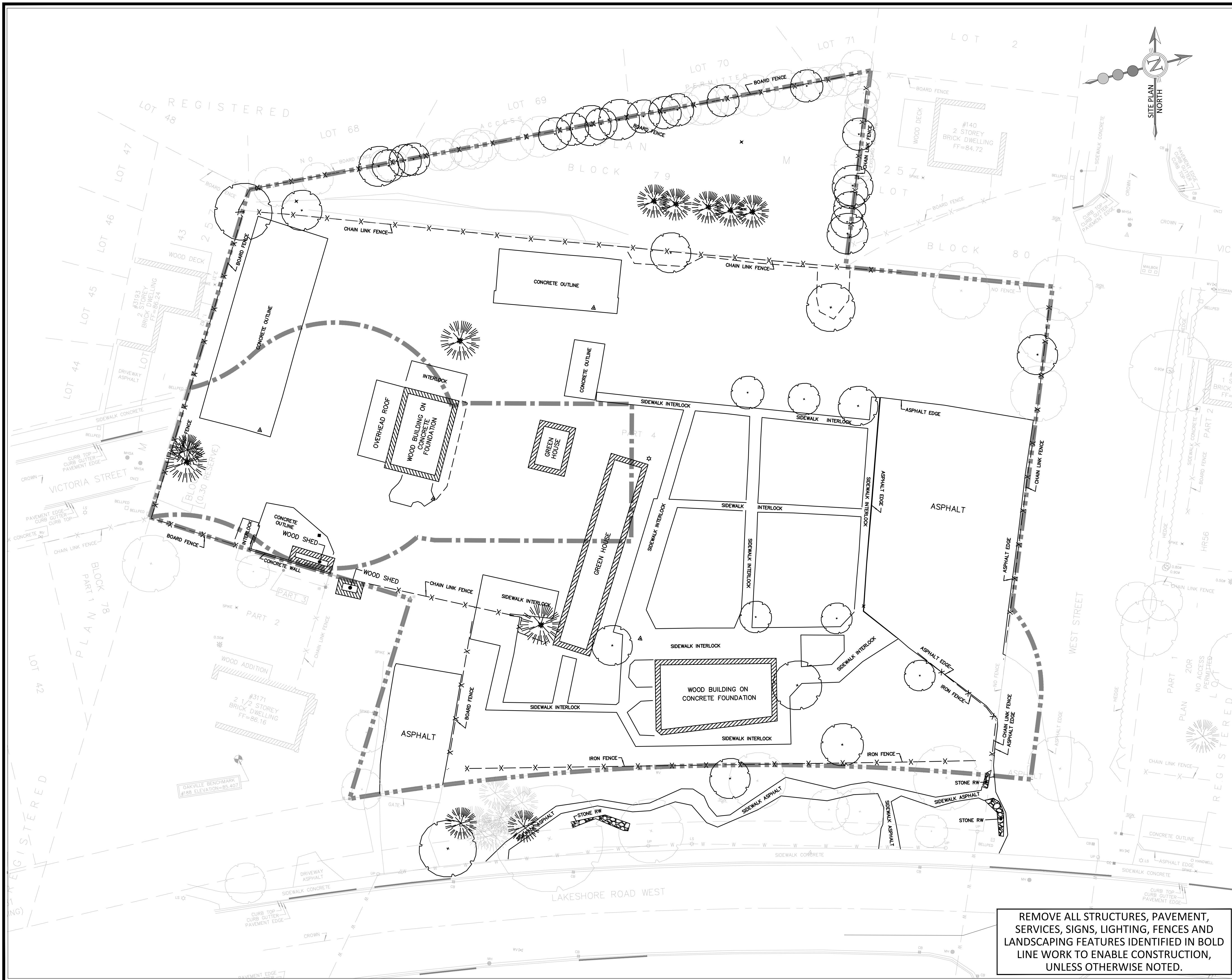

BENCHMARK: ELEV. 85.407
 ELEVATIONS ARE GEODETIC AND ARE REFERRED TO TOWN OF OAKVILLE VERTICAL BENCH MARK NUMBER 188 HAVING AN ORTHOMETRIC ELEVATION OF 85.407 METERS. ELEVATIONS ARE REFERRED TO THE CANADIAN GEODETIC VERTICAL DATUM OF 1925, PRE-1978 ADJUSTMENT (CGVD-1928-PRE-1978 ADJ.).

- LEGEND:**
- — — — — PROPERTY BOUNDARY
 - - - - - LIMIT OF MUNICIPAL PROPERTY
 - EXISTING MANHOLE
 - EXISTING CATCHBASIN
 - ⊕ EXISTING VALVE BOX
 - LS EXISTING LIGHT STANDARD

TOPOGRAPHIC SURVEY PROVIDED BY RPE SURVEYING LTD, MAY 2017

REVISIONS				
No.	DESCRIPTION	DATE	BY	APPROVED
1.	ISSUED FOR SITE PLAN APPLICATION	JAN 20/22	P.G.	
2.	ISSUED FOR SITE PLAN APPLICATION - 2nd SUBMISSION	OCT 14/22	P.G.	
3.	ISSUED FOR SITE PLAN APPLICATION - 3rd SUBMISSION	JAN 20/23	P.G.	
4.	ISSUED FOR SITE PLAN APPLICATION - 4th SUBMISSION	JUN 28/23	P.G.	

SCS consulting group ltd
 30 CENTURIAN DRIVE, SUITE 100
 MARKHAM, ONTARIO L3R 8B8
 TEL: (905) 475-1900
 FAX: (905) 475-8335

OAKVILLE
 1225 TRAFALGAR ROAD
 OAKVILLE, ONTARIO L6H 0H3
 TEL: (905) 845-6601
 FAX: (905) 815-2025

VOGUE WYCLIFFE (OAKVILLE) LIMITED
 3171 LAKESHORE ROAD WEST,
 OAKVILLE

REMOVALS PLAN



DATE:	JUNE 2023	DESIGNED BY:	K.L.	CHECKED BY:	P.G.
SCALE:	1:250	DRAWN BY:	K.L.	CHECKED BY:	P.G.

PROJECT No: **1930**
 DRAWING No: **R-1**

REMOVE ALL STRUCTURES, PAVEMENT, SERVICES, SIGNS, LIGHTING, FENCES AND LANDSCAPING FEATURES IDENTIFIED IN BOLD LINE WORK TO ENABLE CONSTRUCTION, UNLESS OTHERWISE NOTED.

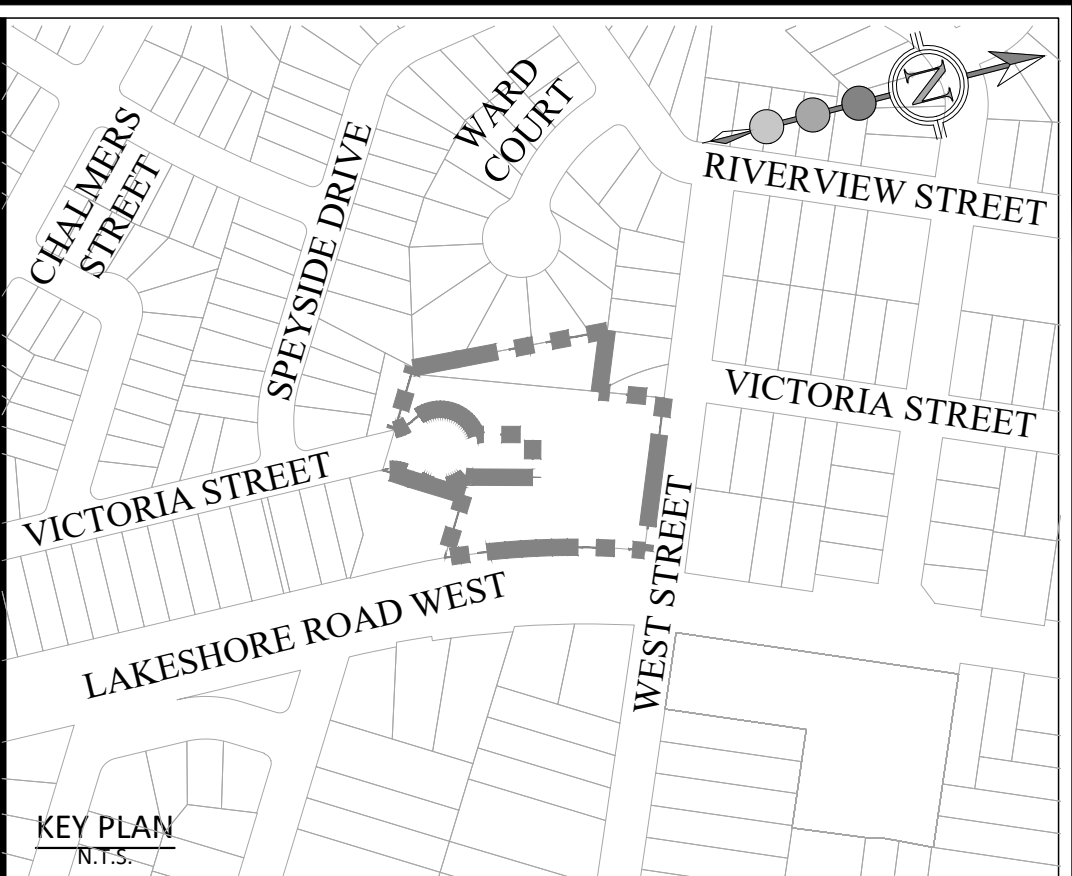
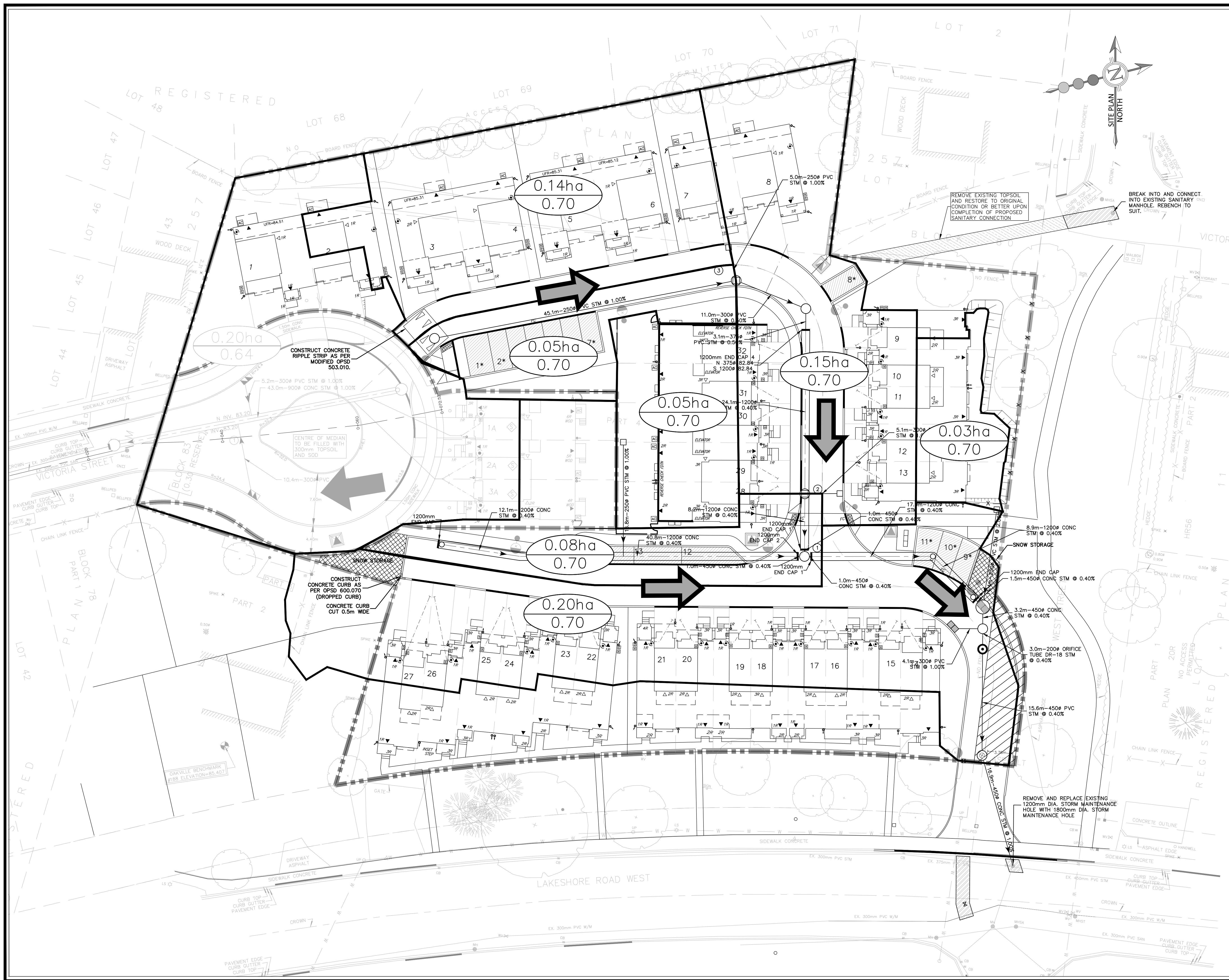

BENCHMARK: ELEV. 85.407
 ELEVATIONS ARE GEODETIC AND ARE REFERRED TO TOWN OF OAKVILLE VERTICAL BENCH MARK NUMBER 188 HAVING AN ORTHOMETRIC ELEVATION OF 85.407 METERS. ELEVATIONS ARE REFERENCED TO THE CANADIAN GEODETIC VERTICAL DATUM OF 1925, PRE-1978 ADJUSTMENT (CGVD-1928-PRE-1978 ADJ.).

- LEGEND:**
- LIMIT OF PROPERTY
 - LIMIT OF MUNICIPAL PROPERTY
 - MAJOR SYSTEM OVERLAND FLOW
 - PROPOSED STORM DRAINAGE BOUNDARY
 - DRAINAGE AREA (HECTARES)
 - RUNOFF COEFFICIENT
 - EXISTING CONTOURS
 - EXISTING STORM SEWER AND MANHOLE
 - PROPOSED STORM SEWER AND MANHOLE
 - PROPOSED SUPERPIPE
 - PROPOSED OIL-GRIT SEPARATOR MANHOLE
 - PROPOSED SUMP PUMP
 - PROPOSED RAIN WATER LEADER

TOPOGRAPHIC SURVEY PROVIDED BY RPE SURVEYING LTD, MAY 2017

REVISIONS				
No.	DESCRIPTION	DATE	BY	APPROVED
1.	ISSUED FOR SITE PLAN APPLICATION	JAN 20/22	P.G.	
2.	ISSUED FOR SITE PLAN APPLICATION - 2nd SUBMISSION	OCT 14/22	P.G.	
3.	ISSUED FOR SITE PLAN APPLICATION - 3rd SUBMISSION	JAN 20/23	P.G.	
4.	ISSUED FOR SITE PLAN APPLICATION - 4th SUBMISSION	JUN 28/23	P.G.	

SCS consulting group ltd
 30 CENTURIAN DRIVE, SUITE 100
 MARKHAM, ONTARIO L3R 8B8
 TEL: (905) 475-1900
 FAX: (905) 475-8335

OAKVILLE
 1225 TRAFALGAR ROAD
 OAKVILLE, ONTARIO L6H 0H3
 TEL: (905) 845-6601

VOGUE WYCLIFFE (OAKVILLE) LIMITED
 3171 LAKESHORE ROAD WEST,
 OAKVILLE

STORM DRAINAGE PLAN



DATE:	JUNE 2023	DESIGNED BY:	K.L.	CHECKED BY:	P.G.
SCALE:	1:500	DRAWN BY:	K.L.	CHECKED BY:	P.G.

PROJECT No: **1930**
 DRAWING No: **DR-1**