

SCP  
00819830482

SCP  
00119653127

LAKESHORE ROAD WEST  
(FORMERLY KNOWN AS THE KING'S HIGHWAY NO. 2)

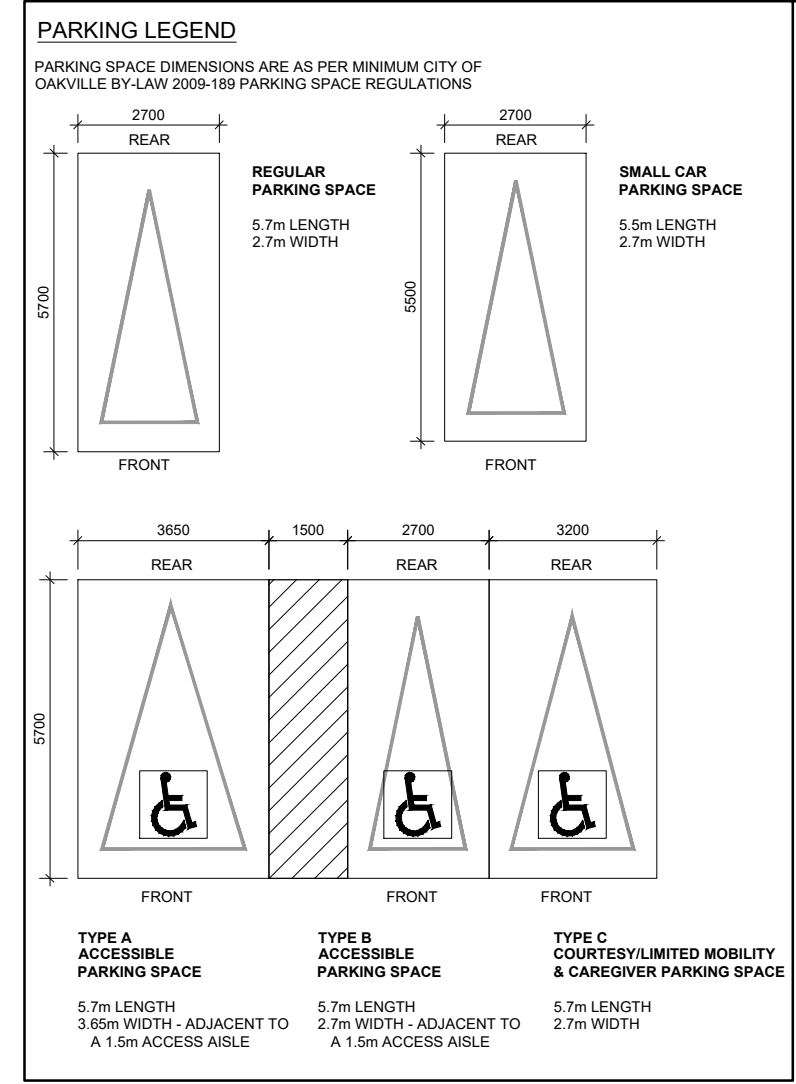
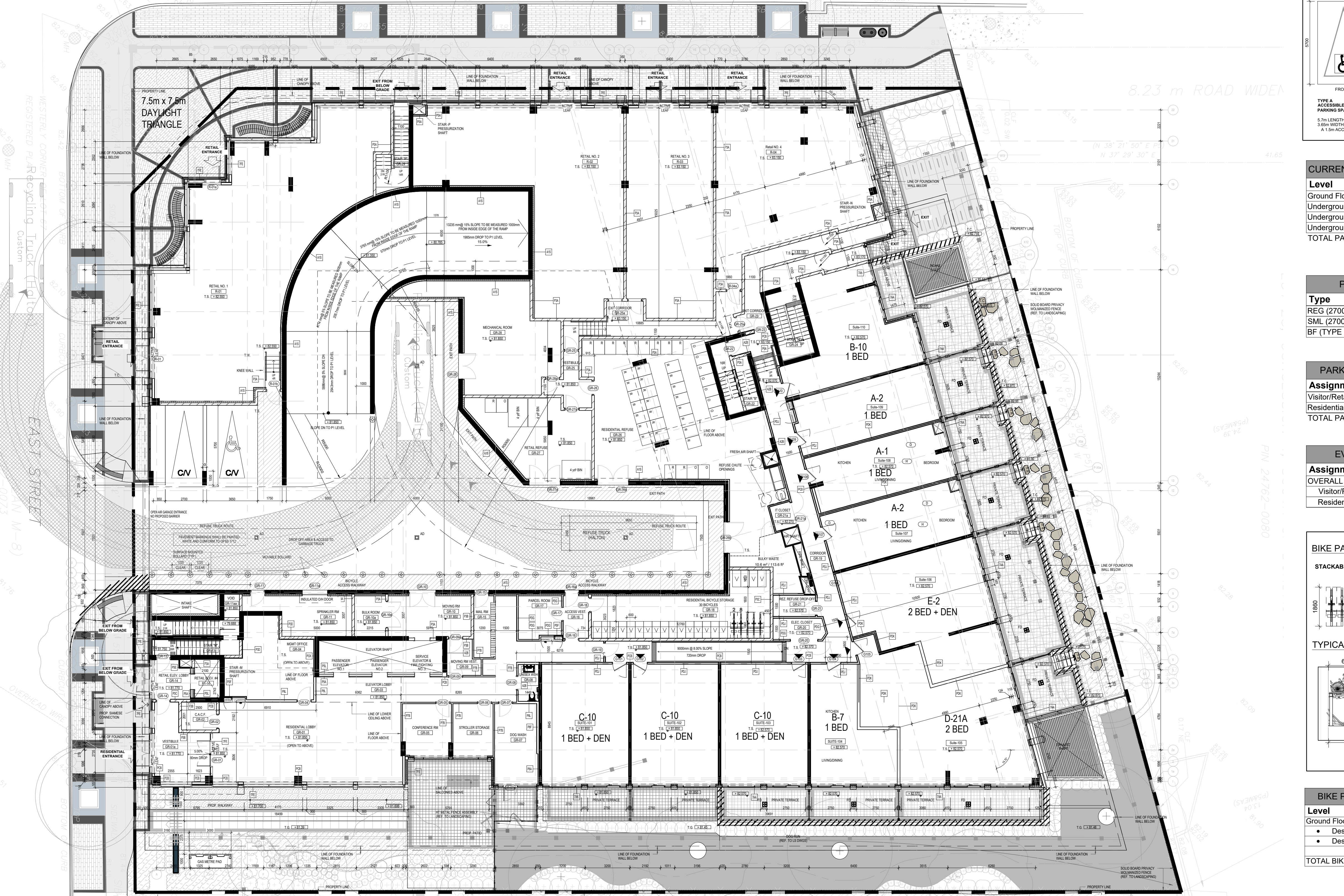

**CURRENT PARKING SPACE COUNT BY LEVEL**

Level	Stall Count
Ground Floor	2
Underground Level P1	75
Underground Level P2	103
Underground Level P3	90
<b>TOTAL PARKING SPACES:</b>	<b>270</b>

**PARKING SPACE COUNT BY SIZE**

Type	Count
REG (2700x5700) - 84.4%	228
SML (2700x5500) - 14.1%	38
BF (TYPE A, B, OR C) - 0.015%	4

**PARKING SPACE COUNT BY ASSIGNMENT**

Assignment	Stall Count
Visitor/Retail	43
Residential	227
<b>TOTAL PARKING SPACES:</b>	<b>270</b>

**EVSE PARKING SPACES PROVIDED**

Assignment	Stall Count
<b>OVERALL</b>	<b>54</b>
Visitor/Retail	8
Residential	46

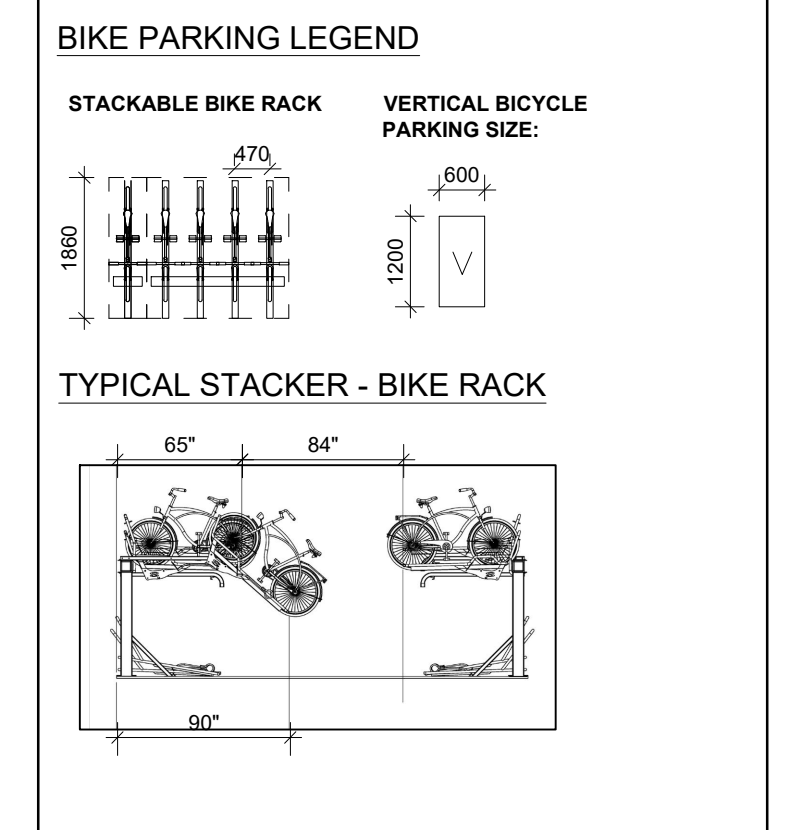

**BIKE PARKING SPACE COUNT BY LEVEL**

Level	Stall Count
Ground Floor	0
Designated for RESIDENTIAL	30
Designated for VISITOR/ RETAIL	12
<b>TOTAL BIKE SPACES</b>	<b>42</b>

PODIUM DEVELOPMENTS

3 BRIDGMAN AVE.  
SUITE #101  
TORONTO, ONTARIO  
M5R 3V4

**ISSUED**

No.	DATE	DESCRIPTION
1	2021/05/18	ISSUED FOR OPA & REZONING
2	2022/10/21	ISSUED FOR SPA
3	2023/03/10	ISSUED FOR SPA 2
4	2023/06/05	ISSUED FOR SPA 3

- GENERAL NOTES**
- DRAWINGS ARE PREPARED BASED ON BOUNDARY PLAN AND TOPOGRAPHICAL SURVEY OF LOTS 57, 58, AND 59 IN THE CITY OF OAKVILLE, AS PREPARED BY J.H. GELBLOOM SURVEYING LIMITED AND DATED MARCH 8, 2021.
  - DRAWINGS ARE TO BE READ IN CONJUNCTION WITH ALL OTHER CONSULTANTS' DRAWINGS AND REPORTS.
  - REFER TO TRAFFIC CONSULTANT'S DOCUMENTATION FOR TRAFFIC DIAGRAMS, TURNING RADIUS, TRAFFIC REPORT AND SITE ACCESS INFORMATION.
  - REFER TO LANDSCAPE ARCHITECT'S DRAWINGS FOR LANDSCAPING INFORMATION AND OUTDOOR AMENITY SPACES.
  - REFER TO SITE SERVICING / CIVIL ENGINEER'S DRAWINGS AND REPORTS FOR SITE SERVICING AND UTILITY INFORMATION.

**COPYRIGHT:**  
Any reproduction or distribution for any purpose other than authorized by IBI Group is forbidden. Written dimensions shall have precedence over scaled dimensions. Contributors shall verify and be responsible for all dimensions and conditions on the job and IBI Group shall be informed of any variations from the dimensions and conditions shown on the drawing. Shop drawings shall be submitted to IBI Group for the general conformances before proceeding with fabrication.

**IBI GROUP ARCHITECTS (CANADA) INC.**  
is a member of IBI Group of companies

**IBI GROUP ARCHITECTS (CANADA) INC.**  
7TH FLOOR - 55 ST. CLAIR AVE. W.  
TORONTO, ONTARIO M4V 2Y7  
tel (416) 596-1930 fax (416) 596-0644  
ibi@ibi.com

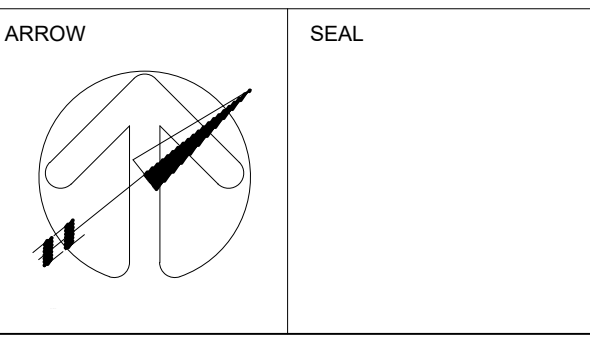

**PROJECT**

**77 EAST**  
(2262-2266 Lakeshore Rd W & 83 East St)  
OAKVILLE, ONTARIO

**SHEET TITLE**

**GROUND FLOOR**

<b>DRAWN BY:</b> Author	<b>CHKD BY:</b> Checker	<b>DATE:</b> 2023/03/03	<b>SCALE:</b> 1:150
<b>PROJECT NO.:</b> 132827	<b>DWG NO.:</b> A1.03		