

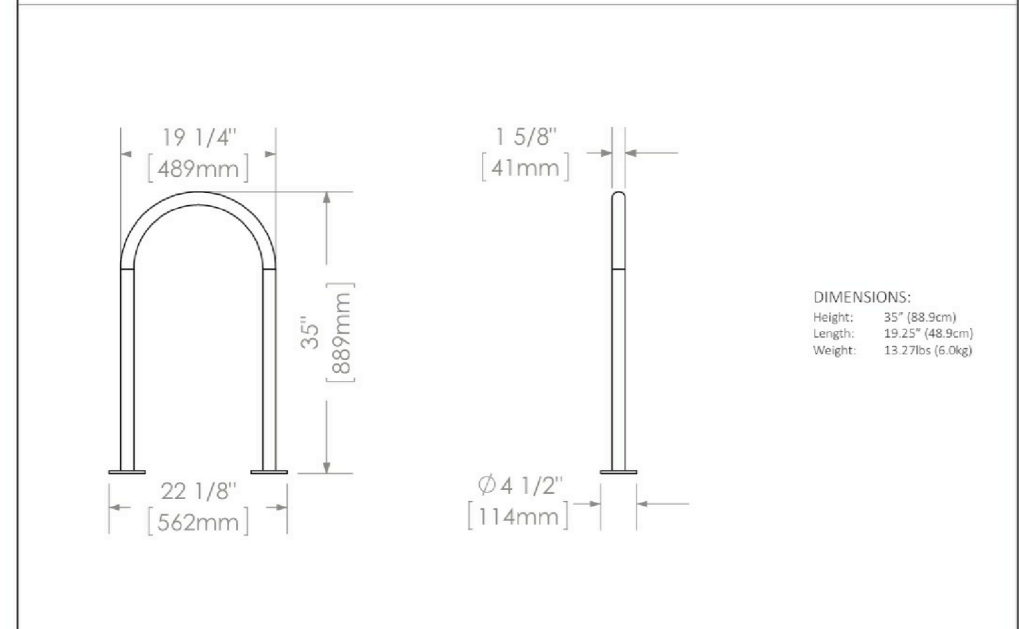

MBR500-S **500 SERIES**

MATERIALS: All parts are made from 11.5 steel tube.
FINISH: All steel components are protected with a clear rust proofing.
INSTALLATION: The bike rack is designed for assembly. It is available with either a surface mount or a direct burial installation option.
TO SPECIFY: Select MBR500-S
 Choose:
 Finish: Powder Coat
 Galvanized Steel
 Surface Mount (MBR500-S-G)



NOTES:
 1. SEE DRAWING FOR DIMENSIONS AND TOLERANCES.
 2. ALL DIMENSIONS ARE TO UNLESS OTHERWISE SPECIFIED.
 3. ALL DIMENSIONS ARE TO UNLESS OTHERWISE SPECIFIED.
 4. ALL DIMENSIONS ARE TO UNLESS OTHERWISE SPECIFIED.

PROPOSED BIKE RACK NTS

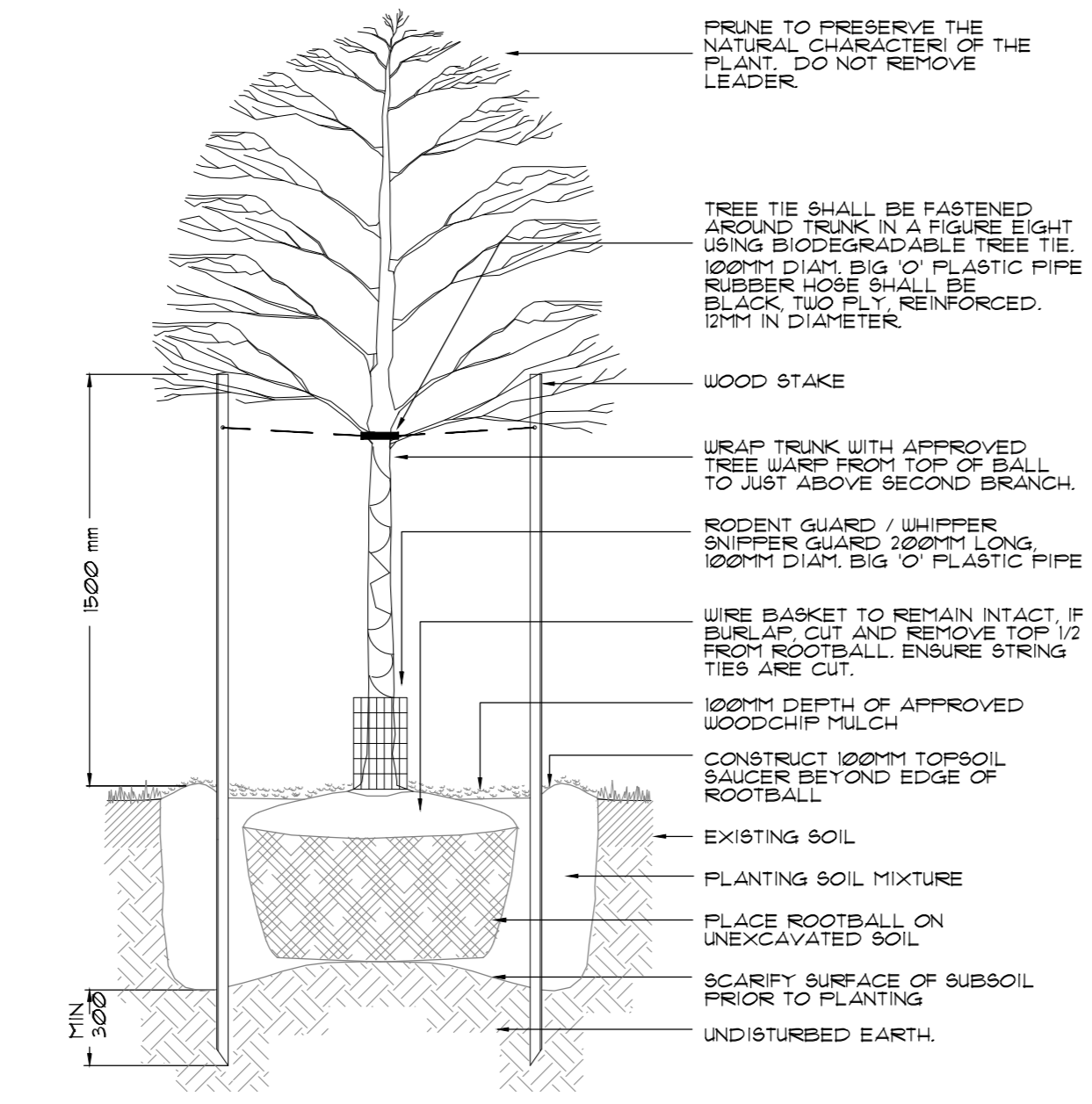

NOTES:
 TREE SHALL BEAR SAME RELATION TO FINISHED GRADE AS IT BORE TO PREVIOUS NURSERY GRADE. THE ABOVE TREE REPRESENTS A TYPICAL DECIDUOUS TREE. TREE SHALL BE PROPERLY WRAPPED DURING TRANSPORT TO PREVENT UNDESIRABLE PRUNE BRANCHES AS NECESSARY ACCORDING TO STANDARD HORTICULTURAL PRACTICES. RETAIN NATURAL SHAPE. DO NOT CUT LEADER.
 TREE PIT TO BE 3X SIZE OF ROOTBALL.
 SOIL PREPARATION AREA TO BE 2X ROOTBALL DIAMETER AROUND TREE PIT.

DECIDUOUS TREE PLANTING NTS

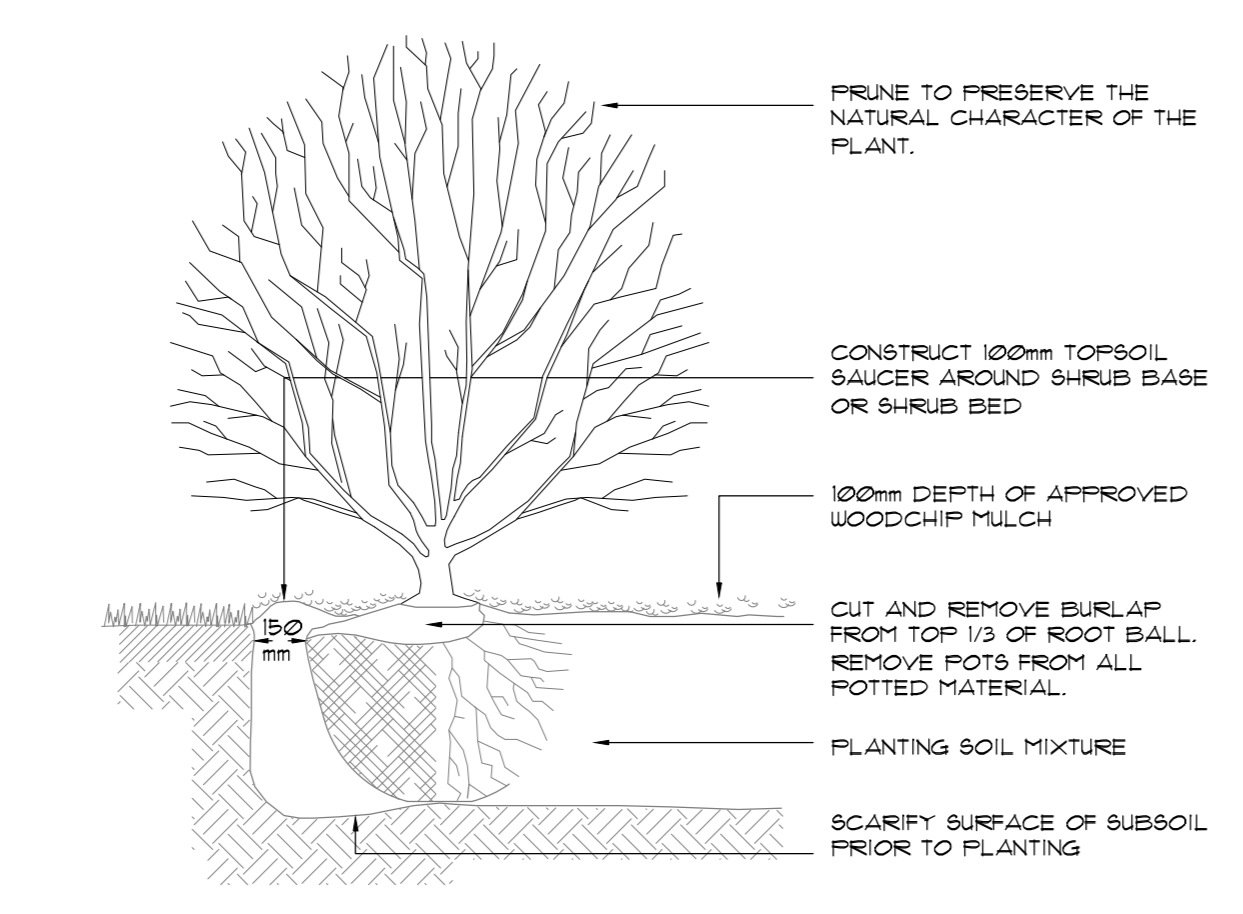

NOTES:
 SHRUB SHALL BEAR SAME RELATION TO FINISHED GRADE AS IT BORE TO PREVIOUS NURSERY GRADE.
 SHRUBS PLANTED IN GROUPS SHALL BE SET IN CONTINUOUS BEDS.
 THE ABOVE DETAIL DOES NOT REPRESENT ANY PARTICULAR SPECIES.

SHRUB PLANTING NTS

- GENERAL NOTES**
- ALL LANDSCAPE WORKS, UNLESS OTHERWISE NOTED, SHALL BE EXECUTED BY ONSITE CREW AND FORE PERSON WITH MINIMUM THREE YEARS OR MORE RELATED EXPERIENCE.
 - LANDSCAPE DRAWINGS ARE NOT TO BE SCALED.
 - NO EXTRA WILL BE CONSIDERED FOR DISCREPANCIES BETWEEN THE DRAWINGS AND ACTUAL SITE CONDITIONS UNLESS REPORTED IN WRITING TO CONSULTANT PRIOR TO COMMENCEMENT OF WORK.
 - DO NOT LEAVE ANY EXCAVATED HOLES OPEN OVERNIGHT.
 - MAKE GOOD ALL DAMAGE RESULTING FROM THE WORK AT NO EXTRA COST.
 - KEEP AREA OUTSIDE CONSTRUCTION ZONE CLEAN AND USABLE BY OTHERS AT ALL TIMES.
 - NO STOCKPILE IS ALLOWED ON SITE WITHOUT OWNER'S APPROVAL AND DIRECTION.
 - IF REQUESTED CONTRACTOR IS TO SUBMIT SAMPLES OF ALL PROPOSED MATERIALS IN THIS CONTRACT FOR APPROVAL BY CONSULTANT PRIOR TO COMMENCEMENT OF WORK.
 - CONTRACTOR RESPONSIBLE FOR STAKE OUT AND VERIFY LOCATIONS FOR ALL UTILITIES PRIOR TO ANY CONSTRUCTION, AND REPORT ALL CONFLICTS TO CONSULTANT IN WRITING, CONTRACTOR TO OBTAIN WRITTEN INSTRUCTIONS PRIOR TO STARTING WORK.
 - THIS DRAWING TO BE READ IN CONJUNCTION WITH ARCHITECT'S SITE PLAN, ENGINEERING DRAWINGS, SOIL REPORTS AND ALL OTHER APPLICABLE DOCUMENTS.
 - ALL SHRUBS AND GROUND COVER TO BE IN CONTINUOUS PLANTING BEDS. ALL PLANTING TO MEET MUNICIPALITY'S SPECIFICATIONS.
 - IF REQUESTED CONTRACTOR TO LAYOUT ALL LANDSCAPE ELEMENTS, AND CONFIRM LOCATIONS WITH THE CONSULTANT PRIOR TO COMMENCEMENT OF WORK.
 - CONTRACTOR MUST ALWAYS FOLLOW THE APPROVED ENGINEERING GRADING PLANS, REPORT ANY DISCREPANCIES TO CONSULTANTS AND SITE SUPERVISOR IMMEDIATELY.
 - ALL PLANT MATERIAL TO BE NURSERY GROWN STOCK BY NURSERY KNOWN IN THE INDUSTRY. PROVIDE IN WRITING SOURCE OF PLANT MATERIAL TO CONSULTANT.
 - CONTRACTOR TO CONFIRM THAT THE PLANT QUANTITIES SHOWN ON THE PLANT LIST CONFORM TO THE LANDSCAPE DRAWINGS. ANY DISCREPANCIES NOT REPORTED AT TIME OF TENDER, SHALL BE THE RESPONSIBILITY OF THE CONTRACTOR.

GENERAL NOTES NTS

- CONTRACTOR SHALL PROVIDE MARKED-UP REDLINE PLANS SHOWING AS-BUILT CONDITIONS TO THE LANDSCAPE ARCHITECT PRIOR TO OBTAINING SUBSTANTIAL COMPLETION.
- CONTRACTOR TO INSTALL NEW SOD AND NEW TOPSOIL AS PER SPECIFICATIONS AND GENERAL NOTES THROUGHOUT THE SITE AS DESIGNED. CONTRACTOR TO VERIFY WITH OWNER AT TIME OF TENDER IF NEW TOPSOIL AND SOD SHALL EXTEND THROUGH THE MUNICIPAL BOULEVARD TO THE REAR OF THE MUNICIPAL CURB.
- CONTRACTOR MUST ADVISE AND OBTAIN WRITTEN APPROVAL FROM THE CONSULTANT AND MUNICIPALITY OF ANY PLANT MATERIAL SUBSTITUTIONS PRIOR TO COMMENCEMENT OF WORK.
- CONTRACTOR WILL NOTIFY THE LANDSCAPE ARCHITECT WHEN WORK IS COMPLETED. WARRANTY PERIOD COMMENCES ONLY WHEN THE CERTIFICATE OF COMPLETION, SUBJECT TO DEFICIENCIES IS RECEIVED BY OWNER.
- CONTRACTOR TO VERIFY ON SITE ALL DIMENSIONS AND SATISFY THEMSELVES OF SITE CONDITIONS. ADVISE CONSULTANT IMMEDIATELY OF ANY CONCERN, PRIOR TO CONSTRUCTION.
- CONTRACTOR TO CONFIRM ISSUED DRAWINGS ARE LATEST REVISED DRAWINGS PRIOR TO TENDER AND/OR PRIOR TO CONSTRUCTION.
- DRAWINGS AND PLANS ARE THE COPYRIGHT PROPERTY OF INSITE LANDSCAPE ARCHITECT INC. ANY UNAUTHORIZED USE IN ANY FORM IS PROHIBITED BY LAW. FURTHER, ANY DISTRIBUTION OF DRAWINGS TO UNAUTHORIZED PERSONS, FIRMS OR COMPANIES IS NOT PERMITTED WITHOUT INSITE LANDSCAPE ARCHITECT INC. PERMISSION. ANY AND ALL VIOLATIONS ARE SUBJECT TO PROSECUTION IN A COURT OF LAW.

GENERAL NOTES - continued NTS

PLANT LIST

NOTE:
 CONTRACTOR TO INQUIRE CONSULTANT IMMEDIATELY IF ANY ERRORS OR DISCREPANCIES ARE NOTED. SHOULD A DISCREPANCY OCCUR BETWEEN PLANT LIST AND SITE, THE GREATER TOTAL SHALL TAKE PRECEDENT. CONTRACTOR TO VERIFY SPECIES AND QUANTITIES PRIOR TO ENTERING INTO AGREEMENT WITH OWNER. PLANT MATERIAL SUBSTITUTIONS ARE NOT PERMITTED AFTER AWARD OF CONTRACT.

KEY	BOTANICAL NAME	COMMON NAME	COND.	CAL.	HT/SFR.	REMARKS	QTY.
TREES							
A	ACER SACCHARUM "AUTUM BLAZE"	SUGAR MAPLE	BB/UB	100MM		UNIFORM	12
B	FAGUS GRANDIFOLIA	AMERICAN BEECH	BB/UB	100MM		UNIFORM	14
C	CARYA OVATA	SHAGBARK HICKORY	BB/UB	100MM		UNIFORM	14
D	JUGLANS NIGRA	BLACK WALNUT	BB/UB	100MM		UNIFORM	15
E	QUERCUS MACROCARPA	BUR OAK	BB/UB	100MM		UNIFORM	14
F	ULMUS X "PIONEER"	PIONEER ELM	BB/UB	100MM		UNIFORM	11
G	ACER X FREEMANII "AUTUM BLAZE"	AUTUMN BLAZE MAPLE	BB/UB	100MM		UNIFORM	5
H	GLEDITSIA TRIACANTHOS VAR. INERMIS "HALKA"	HALKA HONEYLOCUST	BB/UB	100MM		UNIFORM	6
O	ACER SACCHARINUM	SILVER MAPLE	BB/UB	100MM		UNIFORM	6
I	ACER RUBRUM	RED MAPLE	BB/UB	100MM		UNIFORM	9
J	CARPINUS CAROLINIANA	BLUE BEECH	BB/UB	100MM		UNIFORM	9
K	TILIA CORDATA	LITTLE LEAF LINDEN	BB/UB	100MM		UNIFORM	3
L	Ostrya virginiana	IRONWOOD	BB/UB	60MM		UNIFORM	11
M	Syringa reticulata "IVORY SILK"	IVORY SILK TREE LILAC	BB/UB	60MM		UNIFORM	9
N	AMELANCHIER GRANDIFLORA "AUTUMN BRILLIANCE"	AUTUMN BRILLIANCE SERVICEBERRY	BB/UB	60MM		UNIFORM	9
DECIDUOUS SHRUBS							
a	RIBES ALPINUM	ALPINE CURRANT	POT		60CM	EVENLY SPACED	98
b	SPIREA BUMALDA "GOLDFLAME"	GOLDFLAME SPIREA	POT		60CM	EVENLY SPACED	98
c	ROSA RUGOSA	SHRUB ROSE	POT		60CM	EVENLY SPACED	76
d	CARAGAN AURANTIACA	PYGMY PEASHRUB	POT		60CM	EVENLY SPACED	76
e	PHYSOCARPUS OPULIFOLIUS	COMMON NINEBARK	POT		60CM	EVENLY SPACED	60
f	POTENTILLA FRUTICOSA "ANNETTE"	ANNETTE CINQUEFOIL	POT		60CM	EVENLY SPACED	60
g	HYDRANGEA ARBORESCENS "ANNABELLE"	ANNABELLE HYDRANGEA	POT		60CM	EVENLY SPACED	91
CONIFEROUS SHRUBS							
n	EUONYMUS FORTUNEI "EMERALD GAIEY"	EMERALD GAIEY EUONYMUS	POT		60CM	EVENLY SPACED	40
m	TAXUS CUSPIDATA	SPREADING JAPANESE YEW	POT		60CM	EVENLY SPACED	92
o	THUJA OCCIDENTALIS	EASTERN WHITE CEDAR	POT		100CM	EVENLY SPACED	140
GRASSES AND PERENNIALS							
aa	CALAMAGROSTIS ACUTIFLORA "KARL FORSTER"	FEATHER REED GRASS	POT		1 GAL.	EVENLY SPACED	96
bb	HELIOPSIS HELIANTHOIDES "SUNSTRUCK"	SUNSTRUCK FALSE SUNFLOWER	POT		1 GAL.	EVENLY SPACED	8
cc	RUDBECKIA HIRTA	BLACK EYED SUSAN	POT		1 GAL.	EVENLY SPACED	15

ALL WORK SHALL BE CARRIED OUT IN STRICT ACCORDANCE WITH THE REQUIREMENTS OF THE LATEST EDITION OF THE ONTARIO BUILDING CODE AND ANY OTHER AUTHORITY HAVING JURISDICTION. ALL DIMENSIONS TO BE CHECKED AND VERIFIED AT THE SITE BY EACH CONTRACTOR. ANY DISCREPANCIES AND/OR ERRORS SHALL BE REPORTED IN WRITING TO THE CONSULTANT BEFORE COMMENCING ANY WORK. ALL DRAWINGS ARE THE COPYRIGHT OF THE CONSULTANT AND REMAIN THE PROPERTY OF THE CONSULTANT.

THIS DRAWING IS THE PROPERTY OF INSITE LANDSCAPE ARCHITECTS INC. AND MAY NOT BE COPIED IN WHOLE OR PART. NOR MAY ANY INFORMATION CONTAINED THEREIN BE USED WITHOUT WRITTEN PERMISSION OF INSITE LANDSCAPE ARCHITECTS INC.

SITE PLAN INFORMATION PROVIDED BY:
 BALDASSARRA ARCHITECTS INC.
 38 GREAT GULF DRIVE UNIT 20
 CONCORD, ONTARIO L4K 9K7
 905-660-0722
 WWW.BALDASSARRA.CA

- DEC13-22 PROJECT ADDRESS CHANGE, NOTES ADDED. ISSUED FOR CLIENT USE
- DEC6-22 REVISED AS PER NEW SITE PLAN REC'D. DEC5-22 ISSUED FOR CLIENT USE
- DEC5-21 ISSUED FOR CLIENT USE
- DEC3-21 REVISED AS PER NEW SITE PLAN REC'D. DEC3-21 ISSUED FOR CLIENT USE
- DEC3-21 REVISED AS PER MUNICIPAL REQUEST # COORD. ISSUED FOR CLIENT USE
- DEC1-21 REVISED AS PER NEW SITE PLAN REC'D NOV30-21 ISSUED FOR CLIENT USE
- APR1-21 COORDINATION ISSUED FOR CLIENT USE
- APR1-21 ISSUED FOR CLIENT REVIEW

INSITE LANDSCAPE ARCHITECTS INC.
 LANDSCAPE ARCHITECTURE URBAN DESIGN MASTER PLANNING
 info@insiteinc.net

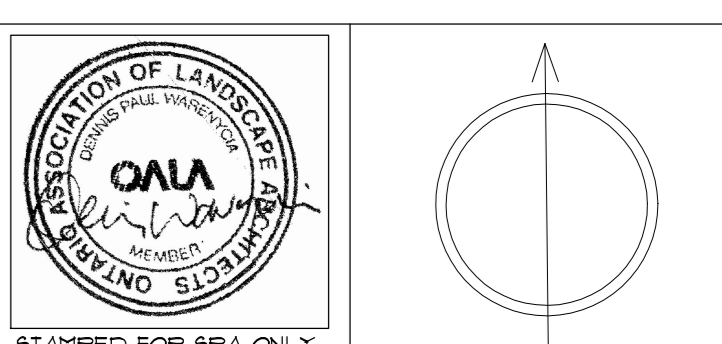

STAMPED FOR SPA ONLY

PROJECT:
 BUILDING A 700 WINSTON CHURCHILL BLVD.
 BUILDING B 750 WINSTON CHURCHILL BLVD.
 OAKVILLE ONTARIO

NOTES AND DETAILS

DATE: MAR.31-21	PROJECT NO: 200907
SCALE: NTS	SHEET: L-4