

**STORMWATER MANAGEMENT
AND FUNCTIONAL SERVICING REPORT**

FOR

**772 WINSTON CHURCHILL BLVD
FENGATE ASSET MANAGEMENT**

TOWN OF OAKVILLE

Project No. 2256

Revision 3: December 19, 2022

Revision 2: December 15, 2021

Revision 1: April 9, 2021

**a.m. candaras associates inc.
8551 Weston Rd, Suite 203
Woodbridge, Ontario
L4L 9R4**



a.m. candaras associates inc.
consulting engineers

TABLE OF CONTENTS

1.	INTRODUCTION.....	1
2.	DESIGN CRITERIA.....	2
3.	SITE DEVELOPMENT STATISTICS	2
4.	PRE-DEVELOPMENT STORMWATER FLOWS	3
5.	STORMWATER MANAGEMENT	4
5.1.	QUANTITY CONTROLS.....	4
5.2.	EXTENDED DETENTION.....	7
5.3.	QUALITY CONTROLS	8
5.4.	STORMWATER MANAGEMENT METHODOLOGY	8
5.5.	GEOTECHNICAL ANALYSIS	9
6.	ROOF TOP CONTROLS.....	10
7.	STORM OUTLET AND PUMPING	12
	Emergency Overland Spillway	13
8.	SANITARY DESIGN.....	14
8.1.	SANITARY DESIGN FLOWS.....	14
9.	WATERMAIN DESIGN	15
9.1.	DOMESTIC AND FIREFLOW DEMAND.....	15
10.	EROSION AND SEDIMENT CONTROLS.....	19
10.1.	EROSION CONTROL AND SEDIMENT CONTROL REQUIREMENTS	19
10.2.	TEMPORARY ESC BASIN DESIGN	19
10.3.	MONITORING PLAN.....	23

LIST OF FIGURES

Figure 1 – Site Location Plan.....	Following Page 1
Figure 2 – Existing Land Use.....	Following Page 1
Figure 3 – Post Development Drainage Areas	Following Page 4

LIST OF APPENDICES

APPENDIX A – BACKGROUND REFERENCE DOCUMENTS

APPENDIX B – STORMWATER MANAGEMENT CALCULATIONS

APPENDIX C – SWMHYMO SIMULATION OUTPUT

APPENDIX D – JELLYFISH DESIGN BRIEF

APPENDIX E – STORM PUMP SPECIFICATIONS

APPENDIX F – GEOTECHNICAL REPORT EXCERPTS

APPENDIX G – SANITARY PUMP SPECIFICATIONS

LIST OF PLANS

G-1..... Grading Plan - North
G-2.....Grading Plan - South
G-3..... Site Servicing and Stormwater Management Plan - North
G-4.....Site Servicing and Stormwater Management Plan - South
ESC-1Sediment and Erosion Control Plan- Stage 1
ESC-2Sediment and Erosion Control Plan-Stage 2

1. INTRODUCTION

This report presents the site servicing and stormwater management analysis for the Fengate industrial development located at 772 Winston Churchill Boulevard, south of Beryl Road in the Town of Oakville, as shown on Figure 1. The total site area is 15.59 ha, in which 11.92 ha will be developed with two Industrial warehouse buildings and associated paved and landscaped areas. The subject property is located in the Clearview Creek subwatershed, in which a portion of the existing watercourse is located within a 40.0m easement block along the west and south property limits.

A Subwatershed Study was completed by McCormick Rankin Corporation (MRC) for the Clearview Creek in May 2007 which established pre-development flow rates. In the 2007 Clearview Creek Subwatershed Study the site area was identified as being part of Subcatchment 5, which had a total area of 24.2 ha. The drainage limits of Subcatchment 5, as delineated in the 2007 Clearview Creek Subwatershed Study, is referenced in Figure 2, with further details of Subcatchment 5 and the related pre-development flow rates provided in Appendix A.

Stormwater management will be provided by a combination of surface stormwater storage and a below ground stormwater storage facility providing quantity control, located within the loading dock areas between Building A and Building B, as shown on Plan G-1. A dry pond area will also provide stormwater storage, located at the southeast corner of the site. The site area will be controlled to the allowable flows protata from the sub-watershed study for the total development area of 11.92 ha and will drain to the southeast and discharge to the realigned channel on the west side of Winston Churchill Boulevard. Quality control will be provided by a series of JellyFish OGS units. Due to various grading constraints, including the floodline elevation in the watercourse and architectural requirements for the building height, the stormwater outlet will be pumped.

The sanitary and water services will connect to municipal mains which are simultaneously being submitted as external works. The sanitary connection will be made through the rear of the site, ultimately discharging to the sanitary sewer on Acacia Court. The watermain connection will be made to the proposed watermain on Winston Churchill Blvd.





LOCATION PLAN

FIGURE 1





a.m.candaras associates inc.
 consulting engineers
 8551 Weston Rd., suite 203, woodbridge ont. L4L 9R4
 (905)850-8020 Fax (905)850-8099
 E-mail: civil@amcai.com

PROJECT:	772 WINSTON CHURCHILL TOWN OF OAKVILLE
SCALE :	N.T.S
DATE:	DECEMBER 2021
PROJ No.	2060



LEGEND

-  SUBCATCHMENT NUMBER
STORMWATER DRAINAGE AREA
-  MAJOR CROSSINGS
-  OVERLAND FLOW

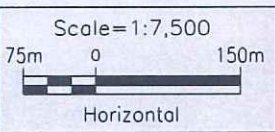
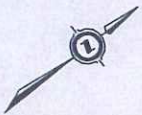

MODIFIED: 07/03/15 16:07:54 DRAWING NAME: K5470-EXISTING LANDUSE.DWG



EXISTING LAND USE

CLEARVIEW CREEK SUBWATERSHED STUDY

EXHIBIT

2

MODIFIED BY A.M. CANDARAS & ASSOCIATES INC.
DATE: DECEMBER 2021

FIGURE 2

2. DESIGN CRITERIA

1. Maximum allowable stormwater discharge to be limited to pre-development flows.
2. On-site detention must be provided to attenuate post development peak flows to the pre-development rates for storms up to and including the 100-year storm.
3. Stormwater quality controls to be based on Type 1 Enhanced Level (80% TSS Removal).

3. SITE DEVELOPMENT STATISTICS

The site will consist of two industrial warehouse buildings and associated paved and landscaped areas. The existing watercourse area and road widening will be excluded from the stormwater management calculations, as the drainage from these areas will not be directed within the site. The site statistics are provided below:

Building A	=	30,905.87m ²	
Building B	=	29,202.56m ²	
Paved	=	45,400.97m ²	
Landscaped:	=	12,641.39m ²	
Development Area:	=		<u>119,150.78m²</u>
Widening:	=	3,703.27m ²	
Watercourse Easement:	=	<u>33,090.99m²</u>	
Site Area	=		<u>155,945.04m²</u>



4. PRE-DEVELOPMENT STORMWATER FLOWS

The site is located in the Clearview Creek watershed, in which pre-development stormwater flow rates for the sub-catchment areas were determined in the 2007 Clearview Creek Subwatershed Study, refer to Appendix A for excerpts.

The development area is located in Catchment 5, as indicated on Figure 2. The pre-development rates for the site area of 11.92ha have been pro-rated based on the total subcatchment area (24.2 ha) discharging to the Clearview Creek realignment. The allowable discharge rates for the development are summarized in Table 1, based on the Chicago Storm (Bloor St. Data).

Table 1 – Calculated Pre-Development Flow Rates Based On Total Area

Storm Event	Pre-Development Pro-Rated Target Rate [m ³ /s]	
	Area (24.2 ha) ⁽⁴⁾	Site Development Area (11.92 ha) ⁽²⁾
25mm Storm ³	-	0.014
2 Year	0.155	0.076
5 Year	0.300	0.148
10 Year	0.413	0.203
25 Year	0.540	0.266
50 Year	0.706	0.348
100 Year	0.869	0.428

1. Pre-development flow rates from Clearview Creek sub-watershed Catchment 5, SWMHYMO model updated by a.m. Candaras & associates, refer to Appendix A.
2. Target flow rates for 772 Winston Churchill Site, prorated based on development area of 11.92 ha.
3. The target discharge rate for the 25mm storm event is based on the average discharge of the 25mm rainfall volume, for the tributary area, over a 48 hour period.



5. STORMWATER MANAGEMENT

Stormwater management for the development will be provided by a combination of below ground storage chambers and surface stormwater ponding, to address quantity control requirements. Extended detention will be provided by detaining the 25mm stormwater volume and releasing this volume over a 48 hour period. Quality control will be provided through the specification of JellyFish units. The stormwater outlet is subject to the floodwater elevations in the adjacent Clearview Creek, and other constraints, which require a pumped stormwater outlet for all storm events. Refer to Plans G-1 to G-4 for the design layout and details of the storage chambers and surface ponding, quality control structures and pumped outlet. The stormwater design is further detailed in the following sections.

5.1. QUANTITY CONTROLS

In order to achieve the required target flow rates, stormwater storage will be provided below ground in StormTech Chambers MC-4500 (1,837m³), through surface ponding in the loading dock area (820m³) and through surface storage in a dry pond area (3,405m³). The proposed stage storage relationship for this facility is shown in Table 2. An extended detention volume of 2,496.0m³ will be provided between the 90.00m and 91.80m elevations, satisfying the required volume of 2,479.7m³. The calculations for the required extended detention volume and release rate are provided below in Section 5.2. Refer to Appendix B for StormTech chamber volume details and Plan G-1 and G-2 for the surface ponding details.

Outlet controls will be provided in MH#4 OCS and will consist of a 63mm orifice at an elevation of 89.15, in order to provide extended/erosion control discharge to satisfy the 25mm storm event. There will also be a 260mm orifice at the elevation 91.80, controlling the remaining storm events to their respective storm target flow rate, up to a maximum discharge of 221l/s. Refer to Table 3 for the Stormwater Management System performance. As demonstrated in Table 3, all storm events satisfy the target flow rates, controlling all storms up to the 100year to the established target flow rate for each respective storm, to a maximum discharge rate of 208 l/s. The surface ponding levels do not exceed 93.58, occurring during the 100year 24h SCS storm event, resulting in a maximum ponding depth of 0.08m in the loading dock area.

Based on the SWMHYMO output results, the erosion control volume of 2,028m³ will be released over a period of 44.2 hours, at a peak release rate not exceeding 0.014m³/s. The time period exceeds 48 hours due to the orifice size required to satisfy the 25mm storm target flow rate.



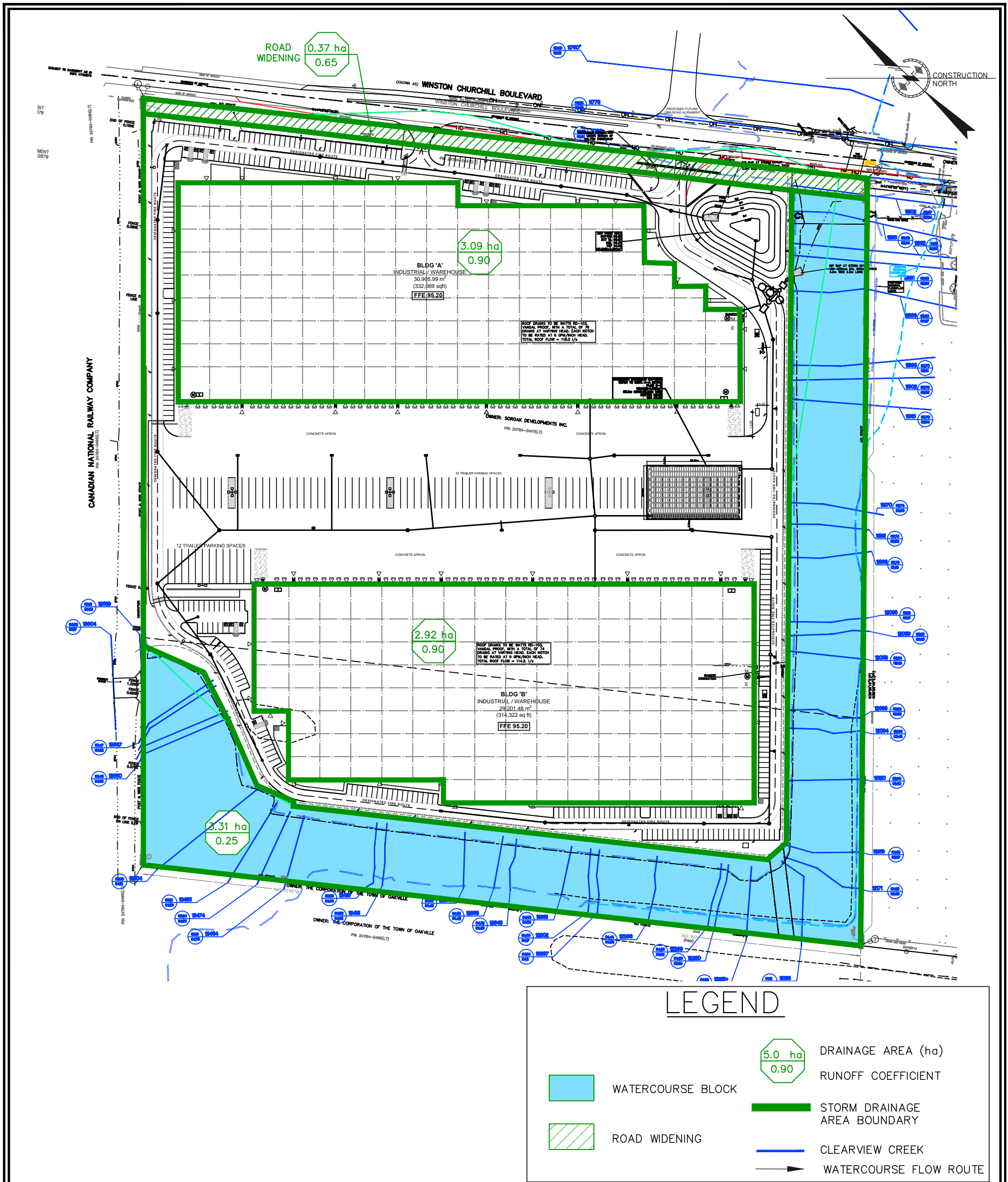

FIGURE 3
POST DEVELOPMENT STORM
DRAINAGE AREA PLAN



a.m.candaras associates inc.
consulting engineers
8551 Weston rd., suite 203
Woodbridge ont. L4L 9R4
905-850-8020 Fax 905-850-8099
Email: civil@amcai.com

772 WINSTON CHURCHILL BLVD
TOWN OF OAKVILLE
ONE PROPERTIES
SCALE 1:2000
DATE: DECEMBER 2022
JOB No. 2256

Table 2 – Below Ground and Surface Stormwater Stage Storage Discharge Relationship

Elevation	VOLUME (m ³)					DISCHARGE (m ³ /s) AND HEAD (m)				SWMHYMO INPUT	
	Dry Pond Area m ²	Dry Pond Volume	MC-4500 Chambers	Surface Ponding	Total	Orifice 1 ⁽¹⁾	Orifice 2 ⁽²⁾	Emergency Overflow ⁽³⁾	Total Flows	Discharge (m ³ /s)	Storage (ha*m)
90.00	110.00	0.00	0.0	0.0	0.0	0.0000			0.0000	0.0000	0.0000
90.10	149.00	12.95	56.8	0.0	69.8	0.0083			0.0083	0.0083	0.0070
90.20	188.00	29.80	113.7	0.0	143.5	0.0088			0.0088	0.0088	0.0143
90.30	227.00	50.55	219.3	0.0	269.9	0.0092			0.0092	0.0092	0.0270
90.40	266.00	75.20	340.3	0.0	415.5	0.0096			0.0096	0.0096	0.0416
90.50	305.00	103.75	460.2	0.0	564.0	0.0100			0.0100	0.0100	0.0564
90.60	344.00	136.20	578.6	0.0	714.8	0.0104			0.0104	0.0104	0.0715
90.70	383.00	172.55	695.3	0.0	867.9	0.0107			0.0107	0.0107	0.0868
90.80	422.00	212.80	809.9	0.0	1,022.7	0.0111			0.0111	0.0111	0.1023
90.90	461.00	256.95	922.1	0.0	1,179.1	0.0114			0.0114	0.0114	0.1179
91.00	500.00	305.00	1,004.5	0.0	1,309.5	0.0117			0.0117	0.0117	0.1309
91.10	530.00	356.50	1,111.5	0.0	1,468.0	0.0120	0.0000		0.0120	0.0120	0.1468
91.20	560.00	411.00	1,214.8	0.0	1,625.8	0.0124	0.0000		0.0124	0.0124	0.1626
91.30	590.00	468.50	1,313.8	0.0	1,782.3	0.0127	0.0000		0.0127	0.0127	0.1782
91.40	620.00	529.00	1,407.7	0.0	1,936.7	0.0130	0.0000		0.0130	0.0130	0.1937
91.50	650.00	592.50	1,495.2	0.0	2,087.7	0.0132	0.0000		0.0132	0.0132	0.2088
91.60	680.00	659.00	1,573.6	0.0	2,232.6	0.0135	0.0000		0.0135	0.0135	0.2233
91.70	710.00	728.50	1,637.4	0.0	2,365.9	0.0138	0.0000		0.0138	0.0138	0.2366
91.80 ⁴	740.00	801.00	1,695.3	0.0	2,496.3	0.0141	0.0000		0.0141	0.0141	0.2496
91.90	770.00	876.50	1,752.1	0.0	2,628.6	0.0143	0.0000		0.0143	0.0143	0.2629
92.00	800.00	955.00	1,808.9	0.0	2,763.9	0.0146	0.0392		0.0538	0.0538	0.2764
92.06	824.00	1,003.72	1,837.3	0.0	2,841.1	0.0148	0.0534		0.0682	0.0682	0.2841
92.20	880.00	1,123.00	1,837.3	0.0	2,960.3	0.0151	0.0770		0.0921	0.0921	0.2960
92.40	960.00	1,307.00	1,837.3	0.0	3,144.3	0.0156	0.1016		0.1172	0.1172	0.3144
92.50	1,000.00	1,405.00	1,837.3	0.0	3,242.3	0.0158	0.1119		0.1277	0.1277	0.3242
92.80	1,120.00	1,723.00	1,837.3	0.0	3,560.3	0.0165	0.1382		0.1547	0.1547	0.3560
93.00	1200.00	1,955.00	1,837.3	0.0	3,792.3	0.0170	0.1533		0.1703	0.1703	0.3792
93.50	1,450.00	2,617.50	1,837.3	0.0	4,454.8	0.0181	0.1856		0.2037	0.2037	0.4455
93.75	1,575.00	2,995.63	1,837.3	820.0	5,653.0	0.0186	0.1999	0.00	0.2185	0.2185	0.5653
94.00	1700.00	3,405.00	1,837.3	5,074.3	10,316.7	0.0191	0.2132	3.20	0.2323	0.2323	1.0317

1. Based on an 63mm orifice set at = 89.15, $Q=CA\sqrt{2gh}$
2. Based on a 260mm orifice set at = 91.80, $Q=CA\sqrt{2gh}$
3. Emergency overflow based on 21.0m wide weir spillway from dry pond to watercourse, at elevation 93.80, $Q=CLH^{3/2}$.
4. Extended detention volume 2,512m³ provided between elevations 90.00 and 91.80.

Table 3 – Below and Above Ground Stormwater Storage Performance

Storm	Pre-Development Flow Rates (m ³ /s)	Inflow (m ³ /s)	Outflow (m ³ /s)	Storage Volume (m ³)	HWL
25mm Storm	0.014	0.923	0.013	2,028	91.46
Chicago Storm 4 hour					
2 Year	0.076	1.297	0.043	2,728	91.97
5 Year	0.148	1.800	0.105	3,087	92.34
10 Year	0.203	2.162	0.138	3,376	92.63
25 Year	0.266	2.544	0.162	3,680	92.90
50 Year	0.348	2.929	0.180	3,977	93.14
100 Year	0.428	3.277	0.196	4,307	93.39
SCS Distribution 24 hour					
2 Year	0.135	0.971	0.088	2,973	92.21
5 Year	0.209	1.220	0.129	3,262	92.52
10 Year	0.269	1.384	0.152	3,557	92.80
25 Year	0.358	1.609	0.182	4,018	93.17
50 Year	0.415	1.748	0.197	4,327	93.40
100 Year	0.500	1.944	0.208	4,827	93.58
Regional ¹	-	1.744	1.602	7,817	93.87

1. Regional storm does not incorporate rooftop storage and control flow. The routing of the Regional storm is based on the outlet pumps being inoperable and the overland spillway occurring at 93.80.



5.2. EXTENDED DETENTION

The proposed below ground stormwater storage system has been designed to provide extended detention for the 25mm storm event, in accordance with MOE stormwater management facility requirements. The target discharge rate has been calculated based on the 25mm runoff volume for the tributary area over a 48 hour period. The 25mm storage volume and target flow calculations are provided below.

25mm Storm Target Flow Rate Calculation

Unit Area	=	1.0 ha
Runoff Coeff	=	0.83
Rainfall Depth	=	25mm
Drain Time	=	48 hours
Volume	=	$1.0\text{ha} \times 0.025\text{m} \times 0.83 \times 10,000 \text{ m}^2/\text{ha}$
	=	$210 \text{ m}^3/\text{ha}$
Average Discharge	=	$210 \text{ m}^3/\text{ha} / 48 \text{ hrs} \times 60 \text{ min}/\text{hr} \times 60 \text{ sec}/\text{min}$
Avg Unit Discharge	=	$0.0012 \text{ m}^3/\text{sec}/\text{ha}$
Site Area	=	11.92 ha
$Q_{25\text{mm}}$ Allow	=	$11.92 \text{ ha} \times 0.0012 \text{ m}^3/\text{sec}/\text{ha}$
	=	$0.014 \text{ m}^3/\text{s}$

25mm Storm Extended Detention Volume Calculation

Site Area	=	11.915ha
Runoff Coeff	=	0.83
Rainfall Depth	=	0.025m
Ext. Detention Vol	=	$11.915 \text{ ha} \times 0.84 \times 0.025\text{m} \times 10,000\text{m}^2/\text{ha}$
	=	$2,4797 \text{ m}^3$



5.3. QUALITY CONTROLS

Stormwater quality controls are required to provide Type 1 Enhanced Level (80% TSS Removal), as indicated in The Clearview Creek subwatershed study prepared by MRC. Quality control for the site area will be provided by three Jellyfish JF12-20-5 units, in parallel, in order to provide 80% TSS removal in accordance with the ETV certification. The design brief for the proposed structures has been included in Appendix C, including the ETV certification. The Jellyfish units will provide 80% TSS removal, sized based on the total development area of 11.92ha at an imperviousness of 85%. Refer to plan G-3 for the JellyFish configuration located immediately upstream of the storm outlet.

5.4. STORMWATER MANAGEMENT METHODOLOGY

The Clearview Creek sub-watershed study, prepared by MRC, proposed a SWM facility be provided for Catchment 5. In order to provide the most efficient use of the site area, a below ground stormwater storage chamber system and quality control unit have been proposed. The alternative SWM strategy was presented to the CVC prior to the SPA submission. The CVC has reviewed to alternative proposal and provide approval to replace a conventional open pond design with a below ground storage system and quality control structures in the form of parallel JellyFish units. Refer to the email correspondence from the CVC planner dated April 22, 2020, provided in Appendix A.

The below ground storage systems, with the design calculations provided in Section 5.1, are intended to function in the same manner as an open pond. Extended detention will be provided by releasing the 25mm storm event over an extend period of time, with a target of 48hours. Quality control will be provided in three parallel Jellyfish units to achieved he required 80% TSS removal.

The below ground storage chambers will not provide an additional risk to the private or public, as the storm water will be stored below ground and will only be accessible through manholes and access chambers, located on private property. An emergency overflow route is provided to the adjacent channel. Should the outlet become completely inoperable, the stormwater will backup within the site up to the overflow elevation of 94.00, which is far below the proposed building finished first floor elevations of 95.20. The proposed buildings will have no basements and will have no openings below the FFE.



5.5. GEOTECHNICAL ANALYSIS

Geotechnical investigation for the subject property have been completed and re-visited based on the evolution of the development plans. Ground water level reading have been summarized for groundwater measurements take in 2016 and 2020 by EXP Services Inc, dated October 23, 2020, refer to Appendix F. In order to evaluate the existing ground water conditions in the vicinity of the proposed dry pond, BH/MH 110, which is located at the downstream portion of the channel, was reviewed. The ground water levels were recorded at 0.90m to 2.17m below the ground surface elevation of 93.65, resulting in groundwater levels of 91.48 and 92.75. The proposed pond bottom of 90.00 would therefore be below the ground water levels. An impermeable based consisting of compacted native clay material is suggested, however additional geotechnical recommendations are being pursued to determine the appropriate course of action in order to prevent the ground water from impacting the dry pond function.



6. ROOF TOP CONTROLS

The proposed industrial buildings will be equipped with control flow roof drains. The design details of the roof slope, roof drain locations, depth of ponding and roof drain model is currently being coordinated with the architectural, mechanical and structural consultants, which are currently in the process of preparing detailed Building Permit submission materials. Excerpts of the architectural drawings, prepared by Baldassarra Architects, and the preliminary mechanical drawings, prepared by GMC Engineering, are provided in Appendix B. The structural design, being completed by J.R Jones Engineering, has accounted for 150mm of stormwater ponding on the roof. The detailed architectural, mechanical, and structural design will be submitted as part of the Building Permit application process.

The roof drains will consist of Watts RD-103 Vandal Proof control flow drains, each with one weir, with a total flow capacity of 5 GPM per inch of water rise. Based on the mechanical plans, a portion of the roof drains will be placed at the low points (6" depth) and some will be located within the slope (4" depth). Canopy drains will also be provided, with a depth of 1". The total flow summary from all roof drains, based on the preliminary mechanical design, are summarized in Table 4 and Table 5 below.

Table 4 - Building A Rooftop Controls

Roof Drain Type	No. of Notches	Flow per Notch ⁽¹⁾	Total Flow (GPM)	Total Flow (l/s)
Low Pt - 6"	38	30 GPM	1,140	71.9
Slope - 4"	36	20 GPM	720	45.4
Canopy - 1"	2	5 GPM	10	0.6
Total Building A Roof Drain Flow			1,870 GPM	118.0 l/s

⁽¹⁾ Based on 5 GPM per one inch of water.

The available roof top storage volume for Building A is 2,575.5m³, based on a maximum ponding depth of 150mm, as indicated in the Rooftop Available Storage calculations located in **Appendix B**.



Table 5 - Building B Rooftop Controls

Roof Drain Depth	No. of Notches	Flow per Notch ⁽¹⁾	Total Flows (GPM)	Total Flows (l/s)
Low Pt - 6"	36	30 GPM	1,080	68.1
Slope - 4"	36	20 GPM	720	45.4
Canopy - 1"	2	5 GPM	10	0.6
Total Building B Roof Drain Flow			1,810 GPM	114.2 l/s

⁽¹⁾ Based on 5 GPM per one inch of water.

The available roof top storage volume for Building B is 2,433.5m³, based on a maximum ponding depth of 150mm, as indicated in the Rooftop Available Storage calculations located in **Appendix B**.

The resulting roof top storage and discharge was calculated using the SWMHYMO model, based on the combined flow rates and available storage volume for both Building A and B. The combined storage-discharge relationship utilized in the SWMHYMO model is summarized in Appendix B. The resulting modelled 100 year volume for roof top storage is 3,294m³ and 3,176m³, for the 4 hour Chicago storm and 24 hour SCS storms respectively. Therefore, based on both analyses, the required stormwater ponding volume can be accommodated on the roof, at a depth of approximately 115mm.



7. STORM OUTLET AND PUMPING

The site area includes a portion of the Clearview Creek Watercourse, which was previously realigned along the west and south perimeter of the property. The realignment design was completed to contain the Regional and 100year flows within the 40m wide channel corridor, as shown on Drawing 10, based on the realignment design prepared by MRC and MMM Group. Refer to Appendix A for a reduced scale plan of Drawing 10.

The Clearview Creek Watershed floodline elevations have been further analysed and updated by the Credit Valley Conservation Authority. The updated Regional and 100 year floodline elevations of the realigned watercourse are provided based on the CVC Flood Hazard Map for the Clearview Creek Watershed, Sheets 2 and 3, refer to plans in Appendix A. The updated Regional and 100year floodline elevations of the watercourse have been shown on the grading plans G-1 and G-2, with the 100year water levels indicated on cross sections along the perimeter of the adjacent development area.

The stormwater outlet for the site will be at the southeast limit of the watercourse, near Winston Churchill Blvd. Due to various constraints on the site, further detailed below, it is proposed that the stormwater outlet be pumped.

The proposed outlet to the watercourse is located in the vicinity of Cross Section 11838, which has a Region highwater elevation of 93.68 and a 100yr water level of 92.86. The finished floor elevation of the proposed buildings is subject to Planning requirements from the Town of Oakville, that the maximum building height of 11.0m be established based on the elevation at the mid-point of the property frontage. The proposed elevation at the midpoint frontage is 95.20, based on the centreline of Winston Churchill Blvd of 94.45 as indicated on Cross Section 1, plan G-1. Therefore, this establishes the building FFE of 95.20, with resulting loading dock elevations of 94.00. In order to accommodate gravity storm sewers within the site area, the resulting storm sewer outlet elevation would be below the regional and 100year water elevations. Based on the grade differential between the proposed storm site sewer system and available outfall elevations, it is proposed that the stormwater outlet be pumped under normal operating conditions.

The proposed storm outlet and pump configuration has been detailed on plan G-3, including the orifice controls (under gravity conditions), the quality controls provided by the off-line parallel JellyFish units, and the stormwater pump chamber discharging to the watercourse. The proposed pump configuration will provide variable discharge rates, in order to achieve a traditional SWM Facility storage-discharge condition. The 25mm storm discharge of 14 l/s will function until the extended detention water level of 91.80 is reached. The total combined pump flow rate is designed to provide a maximum discharge rate of 221 l/s, which will occur



for the greater storm events up to the 100year storm. The maximum flow rate of 221 l/s is slightly greater than the target flow rate for the 10 year storm, based on the 4 hour Chicago storm distribution and the 5year storm based on the 24 hour SCS Distribution.

There will be a total of five (5) pumps provided in the storm pump chamber. Four pumps will operate under normal conditions, working alone or in tandem subject to floats being activated based on the water level in the upstream portion of Outlet Control Structure MH 4. The fifth pump will act as a back pump, should any of the four normal operation pumps become inoperable. A gas generator will also be provided, in the event of a power failure the generator will engage and allow the storm pumps to continue operate. The pumps and generator designs are being completed by John Brooks with preliminary design details provided in Appendix E.

Emergency Overland Spillway

An emergency overland spillway will be provided at southeast corner of the site, within the proposed dry pond area and will be directed to the Clearview Creek channel. In the event that the storm outlet becomes inoperable, stormwater will pond up to the elevation 94.00 and will spill to the south through the 21m spillway into the adjacent channel. The spillway has been designed to convey the uncontrolled 100 year storm and regional flows. Calculations for the flows and the spillway capacity are provided below. A secondary 5.0m wide emergency overflow has also been provided in the loading dock area, to provide an additional relief point. Refer to Plan G-1 for the overflow spillway details.

$$\begin{aligned} Q_{100\text{yr Uncont.}} &= 3.20 \text{ m}^3/\text{s} \\ Q_{\text{Regional}} &= 1.75 \text{ m}^3/\text{s} \end{aligned}$$

Dry Pond - Emergency Overflow Weir Calculation:

$$\begin{aligned} \text{Width} &= 21.0\text{m} \\ \text{Max. Depth} &= 93.95 - 93.75 = 0.20\text{m} \\ Q_{\text{CAP}} &= CLH^{3/2} \\ &= 1.705 \times (21.0\text{m}) \times (0.20\text{m})^{3/2} \\ &= 3.20 \text{ m}^3/\text{s} \end{aligned}$$

Loading Area - Emergency Overflow Weir Calculation:

$$\begin{aligned} \text{Width} &= 5.0\text{m} \\ \text{Max. Depth} &= 94.15 - 94.00 = 0.15\text{m} \\ Q_{\text{CAP}} &= CLH^{3/2} \\ &= 1.705 \times (5.0\text{m}) \times (0.15\text{m})^{3/2} \\ &= 0.50 \text{ m}^3/\text{s} \end{aligned}$$



8. SANITARY DESIGN

8.1. SANITARY DESIGN FLOWS

The combined sanitary flow from Building A and B will discharge to the southwest corner of the site and will drain to the sanitary lift station at MH 10A. The sanitary pumps have been designed by John Brooks, with design details provided in Appendix G. A forcemain will be installed through the existing 400mm dia sleeve previously constructed below the existing watercourse, from MH10A to convey the sanitary flows to MH 1A. The forcemain will discharge into to a proposed 250mm sanitary sewer which will be located in an easement to the west of the site and extended through the open space block, ultimately connecting to the existing 750mm trunk sewer at Acacia Court and Deer Run Avenue. For the external sanitary works downstream of this site a separate FSR for the Industrial Developments located at 772, 560, 568 and 824 Winston Churchill Boulevard dated August 31, 2020 has been completed and submitted to the Town of Oakville and Halton Region for approval.

The population for Building A and Building B is based on the Region of Halton population density for commercial/industrial developments. The total sanitary sewage flows from the site area 17.3 l/s, refer calculations below:

Site Development Area	=	11.92 ha
Population Density	=	125 persons/ha
Total Population	=	1,490 people
Sanitary Flow Rate	=	34.375 m ³ /ha/day
Peaking Factor M	=	$0.8 \cdot \left(1 + \frac{14}{4+P^{0.5}}\right)$ where P = Populations in thousands
	=	$0.8 \cdot \left(1 + \frac{14}{4+(1.490)^{0.5}}\right) = 2.95$
Peak Sewage Flow Q	=	$\frac{A \times q \times m}{86400} + IA$
	Q	= $\frac{11.92 \times 34.375 \text{ m}^3/\text{ha}/\text{day} \times 2.95}{86400}$
	=	14.0 l/s + IA
Infiltration	=	11.92 ha x 0.00028 m ³ /sec/ha
	=	0.0033 m ³ /sec
Total Peak Flow	=	14.0 l/s + 3.3 l/s
	=	17.3 l/s



9. WATERMAIN DESIGN

The proposed development will connect to a proposed 300mm watermain along Winston Churchill Boulevard. On site there will be a 100mm domestic and 200mm fireline that will service both buildings, as shown on Plan G-3 and G-4. The watermain connection for Building A and Building B will be on the south side of each building.

9.1. DOMESTIC AND FIREFLOW DEMAND

The domestic demands were based on the Water and Wastewater Linear Design Manual (October 2019) by Halton Region. The water demand for this site is outlined below:

Site Area	=	11.92 ha
Population Density	=	125 persons/ha (Light Industrial Area)
Total Population	=	1,490 people
Consumption	=	275 l/person/day
Max Day Factor	=	2.25
Peak Hour Factor	=	2.25

Water Demands

Average Daily Demand

$$\begin{aligned} &= 275 \text{ l/capita/day} \times 1,490 \text{ people} \\ &= 409,750 \text{ l/day} \\ &= 4.74 \text{ l/s} \end{aligned}$$

Maximum Daily Demand

$$\begin{aligned} &= 275 \text{ l/capita/day} \times 1,490 \text{ people} \times 2.25 \text{ (Max day factor)} \\ &= 921,937.5 \text{ l/day} \\ &= 10.7 \text{ l/s} \end{aligned}$$

Peak Hour Demand

$$\begin{aligned} &= 275 \text{ l/capita/day} \times 1,490 \text{ people} \times 2.25 \text{ (Peak Hour factor)} \\ &= 921,937.5 \text{ l/day} \\ &= 10.7 \text{ l/s} \end{aligned}$$



Fire Flow Calculation

Building A

1. An estimate of the fire flow required for a given area is determined by the formula:

$$F = 220C\sqrt{A}$$

Where, F = the required fire flow in litres per minute l/m
C = Construction type coefficient= 0.8 (Non-combustible construction)
A = Total area (based on construction type and protected openings)

Building Area = 32,490 m²

$$F = 220(0.80)\sqrt{32,490 \text{ m}^2}$$
$$F = 23,793 \text{ l/m (397 l/s)}$$

Therefore use: $F = 24,000 \text{ l/m (400 l/s)}$

2. Occupancy Reduction

Office Area = 0% Increase based on Commercial buildings

∴ Total Reduction = 0%

$$F_2 = 24,000 \text{ l/m} - (24,000 \text{ l/m} \times 0\%)$$

$$F_2 = 24,000 \text{ l/m (400 l/s)}$$

3. Sprinkler Reduction

30% Reduction for NFPA 13 System

4. Separation Charge

East Side (30.1 - 45m) = 0%

West Side (20.1 - 30m) = 0%

North Side (> 45m) = 0%

South Side (> 45m) = 0%

Total Separation Charge = 0%

$$F_{final} = F_2 - (F_2 \times 30\%) + (F_2 \times 0\%) + (F_2 \times 0\%)$$

$$F_{final} = 24,000 \text{ l/m} - (7,200 \text{ l/min}) + (0 \text{ l/min}) + (0 \text{ l/min})$$

$$F_{final} = 16,800 \text{ l/min (280 l/s)}$$

Therefore use: $F_{final} = 17,000 \text{ l/min (283 l/s)}$

$$F_{final} = 4,491 \text{ US gpm}$$



The water supply system will be designed to convey the greater of the fire flow plus maximum day demand or the peak hour demand. The greater flow results from the fire flow plus max day, as calculated below.

$$\begin{aligned}
 \text{Fire Flow + Max Day} &= 283 \text{ l/s} + 10.7 \text{ l/s} \\
 &= 393.7 \text{ l/s} \\
 &= 23,622 \text{ l/min (6,240 US gpm)}
 \end{aligned}$$

Building B:

Fire Flow Calculation (Based on Fire Underwriters Survey 1999)

1. An estimate of the fire flow required for a given area is determined by the formula:

$$F = 220C\sqrt{A}$$

Where, F = the required fire flow in litres per minute l/m
 C = Construction type coefficient= 0.8 (Fire resistive construction)
 A = Total area (based on construction type and protected openings)

$$\text{Building Area} = 28,972 \text{ m}^2$$

$$\begin{aligned}
 F &= 220(0.80)\sqrt{28,972 \text{ m}^2} \\
 F &= 22,468 \text{ l/m (374.5 l/s)}
 \end{aligned}$$

Therefore use: $F = 22,000 \text{ l/m (367 l/s)}$

2. Occupancy Reduction

Office Area = 0% Increase based on Commercial buildings

∴ Total Reduction = 0%

$$F_2 = 22,000 \text{ l/m} - (22,000 \text{ l/m} \times 0\%)$$

$$F_2 = 22,000 \text{ l/m (367 l/s)}$$

3. Sprinkler Reduction

30% Reduction for NFPA 13 System

4. Separation Charge

East Side (20.1 - 30m) = 0%

West Side (> 45m) = 0%

North Side (> 45m) = 0%

South Side (> 45m) = 0%

Total Separation Charge = 0%



$$F_{final} = F_2 - (F_2 \times 30\%) + (F_2 \times 0\%)$$

$$F_{final} = 22,000 \text{ l/m} - (6,600 \text{ l/min}) + (0 \text{ l/min})$$

$$F_{final} = 15,400 \text{ l/min (257 l/s)}$$

Therefore use: $F_{final} = 15,000 \text{ l/min (250 l/s)}$
 $F_{final} = 3,963 \text{ US gpm}$

The water supply system will be designed to convey the greater of the fire flow plus maximum day demand or the peak hour demand. The greater flow results from the fire flow plus max day, as calculated below.

$$\begin{aligned} \text{Fire Flow + Max Day} &= 250 \text{ l/s} + 10.7 \text{ l/s} \\ &= 260.7 \text{ l/s} \\ &= 15,642 \text{ l/min (4,132 US gpm)} \end{aligned}$$

A fire flow hydrant test will be undertaken once the proposed 300mm watermain is constructed on Winston Churchill Boulevard.



10. EROSION AND SEDIMENT CONTROLS

During construction, temporary erosion and sediment controls are to be provided in accordance with the “Erosion and Sediment Control Guidelines for Urban Construction” (2006), prepared by the Greater Golden Horseshoe Conservation Authorities. Erosion control measures will be provided through the use of silt fences, diversion swales, inlet protection devices, sediment traps and temporary sediment pond. The sediment basin and interceptor swales previously completed during the watercourse realignment works are still in place and will be maintained during the initial earthworks and construction as part of the Stage 1 erosion and sediment controls. Refer to Plans ESC-1 and ESC-2 for the stage 1 and stage 2 erosion and sediment control plans.

10.1. EROSION CONTROL AND SEDIMENT CONTROL REQUIREMENTS

The erosion and sediment control requirements for the proposed development are as follows:

1. The Contractor will provide temporary excavated sediment traps for sediment control. The sediment traps should be located at points of discharge from the area.
2. The Contractor will monitor the quality of stormwater discharging from the temporary ESC basin and sediment traps during the construction period.
3. The Contractor will construct temporary drainage systems, such as ditching, temporary culverts to facilitate drainage from exposed soils to the temporary ESC basin and sediment traps.
4. Silt fences will be installed around the exposed area of the temporary ESC basin.
5. The exposed soils will be vegetated as soon as possible. Erosion control blankets should be placed where applicable.
6. Straw bales and/or rock protection will be placed in temporary drainage conveyance channels on steep grades.
7. Rock protection will be placed at points of concentrated discharge, which includes the outlet of the sediment basin.
8. Stockpiled excavated material, and topsoil will be protected from wind and rain erosion.
9. The sediment basin will be cleaned of sediment upon completion of construction and decommissioned.

10.2. TEMPORARY ESC BASIN DESIGN

The temporary sediment basin sizing calculations have been provided below. Refer to the Erosion and Sediment Control Plan - Stage 1 Plan ESC-1 for additional details of the proposed ESC measures and staging notes.



Temporary Sediment Basin Calculations:

Tributary Site Area:	11.92 ha
Required Wet Volume:	125 m ³ /ha x 11.92 ha = 1,490 m ³
Required Dry Volume:	125 m ³ /ha x 11.92 ha = 1,490 m ³
Bottom Pond Elevation:	92.30 m
Bottom Pond Area:	1,915 m ²
Wet/Perm Water Elevation:	93.00 m
Wet/Perm Pond Area:	2,510 m ²
Permanent Volume Provided:	[(1,915 + 2,510)/2] x (93.00 - 92.30) = 1,548.75m ³
Dry Water Elevation:	93.60 m
Dry Pond Area:	3,070 m ²
Dry Volume Provided:	[(3,070m ² + 2,510m ²)/2] x (93.60 - 93.00) = 1,674m ³
Emergency Overflow Elevation:	93.70 m
Top of Pond:	94.00 m

Orifice Sizing Calculations

The dry storage volume is to drain over a 24 to 48 hour period. The orifice was sized to provide the required drain time, based on the MOE Drawdown time (Equation 4.10)

$$t = \frac{2A_p}{(CA_o)\sqrt{2g}} (\sqrt{h_1} - \sqrt{h_2})$$

t =	draw down time in seconds
A _p =	surface area of the pond (m ²)
C =	discharge coefficient (0.63)
A _o =	cross-sectional area of the orifice
g =	gravitational acceleration constant
h ₁ =	(9.81m/s ²)
h ₂ =	starting water elevation above the orifice ending water elevation above the orifice

$$t = \frac{2 \times 2,790.0}{(0.63 \times 0.0095)\sqrt{2 \times 9.81}} (\sqrt{0.60})$$

$$t = 171,133 \text{ sec}$$

$$t = 47.5 \text{ hr}$$

t = draw down time in seconds

A_p = 2,790.0 m² (average at elevations 93.60 m and 93.00 m)

C = discharge coefficient (0.63)

A_o = ((π x (0.110 m²) ÷ 4) x 3 = 0.0095 m²

g = gravitational acceleration constant (9.81m/s²)

h₁ = 93.60 m

h₂ = 93.00 m



Temporary ESC Basin Emergency Overflow Calculations

$$\begin{aligned}
 Q &= \text{CAIN} \\
 A_{\text{SITE}} &= 11.92 \text{ ha} \\
 C_{\text{SITE}} &= 0.25 \\
 I_{100\text{yr}} &= 160 \text{ mm/hr} \quad (\text{based on Oakville IDF, } T_c = 10.0\text{min}) \\
 Q_{100\text{yr}} &= [(0.25 \times 11.92\text{ha})] \times 160 \text{ mm/hr} \times 2.778 \\
 &= 1.325 \text{ m}^3/\text{s}
 \end{aligned}$$

Emergency overflow capacity has been calculated based on flow through a weir:

$$\begin{aligned}
 Q_{\text{WEIR}} &= CLH^{3/2} \\
 C &= 1.705 \\
 L &= 5.0 \text{ m} \\
 H &= 94.00 - 93.70 = 0.30\text{m} \\
 Q_{\text{WEIR}} &= 1.705 \times 5.0\text{m} \times (0.30)^{3/2} \\
 &= 1.40 \text{ m}^3/\text{s}
 \end{aligned}$$

Southwest Forebay Inlet:

Equation 4.5: Forebay Settling Length

$$\begin{aligned}
 \text{Dist} &= \sqrt{\frac{rQ_p}{V_s}} & \text{where: Dist} &= \text{sediment forebay length (m)} \\
 & & Q_p &= \text{peak flow rate from the pond during} \\
 & & & \text{design quality storm (0.020m}^3/\text{s @ 93.60)} \\
 \text{Dist} &= \sqrt{\frac{2(0.020)}{0.0003}} & V_s &= \text{settling velocity (0.0003m/s)} \\
 & & r &= \text{length-to-width ratio of forebay (2:1 min)} \\
 &= 11.40 \text{ m}
 \end{aligned}$$

Equation 4.6: Dispersion Length

$$\begin{aligned}
 \text{Dist} &= \frac{8Q}{dV_f} & \text{where: Dist} &= \text{sediment forebay length (m)} \\
 \text{Dist} &= \frac{8 \times 0.372}{0.70 \times 0.5} & Q &= \text{inlet flow rate (0.372 m}^3/\text{s, based on} \\
 & & & \text{the 5year storm event, 5.35ha area)} \\
 &= 8.5 \text{ m} & V_f &= \text{desired velocity in the forebay (0.5m/s)} \\
 & & d &= \text{depth of permanent pool (0.70m)}
 \end{aligned}$$



Equation 4.7: Minimum Forebay Deep Zone Bottom Width

$$\begin{aligned} \text{Width} &= \frac{\text{Dist}}{8} = \frac{11.42}{8} \\ &= 1.40\text{m} \end{aligned}$$

North Forebay Inlet:

Equation 4.5: Forebay Settling Length

$$\begin{aligned} \text{Dist} &= \sqrt{\frac{rQ_p}{V_s}} & \text{where: Dist} &= \text{sediment forebay length (m)} \\ & & Q_p &= \text{peak flow rate from the pond during} \\ & & & \text{design quality storm (0.020m}^3\text{/s @ 93.60)} \\ \text{Dist} &= \sqrt{\frac{2(0.020)}{0.0003}} & V_s &= \text{settling velocity (0.0003m/s)} \\ &= 11.42 \text{ m} & r &= \text{length-to-width ratio of forebay (2:1 min)} \end{aligned}$$

Equation 4.6: Dispersion Length

$$\begin{aligned} \text{Dist} &= \frac{8Q}{dV_f} & \text{where: Dist} &= \text{sediment forebay length (m)} \\ \text{Dist} &= \frac{8 \times 0.456}{0.70 \times 0.5} & Q &= \text{inlet flow rate (0.456 m}^3\text{/s, based on} \\ &= 10.4 \text{ m} & & \text{the 5year storm event, 6.57 ha area)} \\ & & V_f &= \text{desired velocity in the forebay (0.5m/s)} \\ & & d &= \text{depth of permanent pool (0.70m)} \end{aligned}$$

Equation 4.7: Minimum Forebay Deep Zone Bottom Width

$$\begin{aligned} \text{Width} &= \frac{\text{Dist}}{8} = \frac{11.42}{8} \\ &= 1.4\text{m} \end{aligned}$$

The south sediment forebay inlet will have a total flow length of 11.5 m and width of 11.5m. The north sediment forebay inlet will have a minimum flow length of 11.5m and a width of 13.8m. Therefore, the sediment forebay will promote localized settling of particulate matter during earthwork activities.



10.3. MONITORING PLAN

The monitoring plan for the development site will be implemented for three stages of development: pre-development, construction, and post-construction. The monitoring plan will be as recommended by the Clearview Creek subwatershed study. Excerpts of the recommended monitoring plan is provided in Appendix A.

As described in the subwatershed study:

The development / activity driven monitoring should follow three stages: the pre-development phase, the construction phase, and the post-construction phase. During the pre-development phase, monitoring should be undertaken to generate any additional baseline data that may be required to compile a more detailed understanding of existing conditions. In the construction phase, the purpose of monitoring will be to ensure that the environmental measures implemented during construction are performing as expected (i.e. sediment control by provision of silt fences and temporary sediment traps/basins). Monitoring during the post-construction phase will be conducted to confirm that the performance targets are being achieved and to ensure that no negative environmental changes are occurring because of development.

During Construction Monitoring Program:

During construction, the monitoring program of the SWM facilities, including the temporary sediment control facilities such as excavated sediment traps, should include the following:

- Weekly inspections of the facilities
- Inspections of the control facilities and the receiving water course (Clearview Creek), after rainfall events with at least 10mm of precipitation
- Measurement of suspended solids downstream of the control works

Weekly inspection reports should be submitted by the developer's engineer to the satisfaction of the Town of Oakville. The reports should summarize the state of the control works, their performance during rainfall events, any presence of downstream erosion or sediment accumulation, and any actions necessary to modify the works.



Post-Construction Monitoring Program:

A monitoring response and maintenance program (MRM Program) will be initiated upon completion of the 'During Construction Monitoring Program' and will extend for a 2-year period following substantial completion. Refer to Section 5.2 of the subwatershed study (also provided in Appendix A of this report) for details and requirements of the post-construction monitoring program.

Prepared by,
a.m. candaras associates inc.



A.M. Candaras, P. Eng.
Consulting Engineer



Fanche Petkovski, P.Eng
December 19, 2022



**APPENDIX A
BACKGROUND REFERENCE
DOCUMENTS**

FLOOD HAZARD MAP

CLEARVIEW CREEK WATERSHED

LEGEND

Bridges.....	Overhead Walkway.....	Municipal Boundary.....	Wall.....
Building.....	Parcel Fabric.....	Overhead Walkway.....	Watershed Boundary.....
Building Ruin.....	Parking Lot.....	Parcel Fabric.....	Waterbody Elevation.....
Building Under Construction.....	Pile.....	P/A.....	Wooded Area.....
Contour Index.....	Pipe.....	PLAY.....	Regulatory Floodline.....
Contour Intermediate.....	Pit.....	PLAY.....	Regulatory Floodplain (2D Model).....
Culvert to Scale.....	Playground.....	PLAY.....	1D-2D Model Limits.....
Culvert Symbol.....	Road.....	PLAY.....	Two-Zone Policy Area.....
Dam.....	Road Understruction (UC).....	UC.....	Section.....
Ditch.....	Sidewalk.....	UC.....	Overflow Section.....
Dock, Wharf, Pier.....	Spot Height.....	+123.45.....	Structure ID.....
Driveway.....	Trill.....	+123.45.....	Spill.....
Falls, Rapids.....	Trill.....	+123.45.....	Regional Flood Elevation.....
Flow Direction.....	Trill.....	+123.45.....	Section Number.....
Footbridge.....	Trill.....	+123.45.....	100 Year Flood Elevation.....
Guideroil.....	Trill.....	+123.45.....	
Headwall.....	Trill.....	+123.45.....	
Hedge.....	Trill.....	+123.45.....	
Marsh.....	Trill.....	+123.45.....	

Note: The Regulatory flood elevation and floodline is the greater of the Regional and 100 Year storms. See General Note 6 concerning Section Numbers marked with an *.

SHEET INDEX

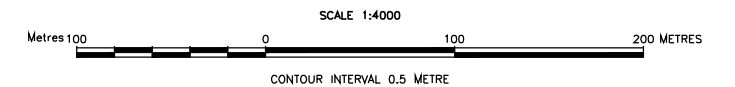
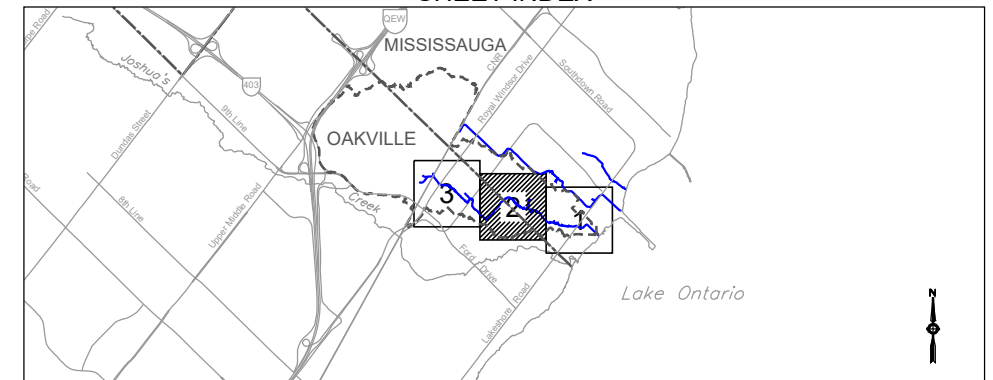

General Notes:

- Contourlines on this map were generated by Airborne Imaging using the Spring of 2015 LIDAR point cloud, breaklines and hydrologic enforcement of bridges. The vertical accuracy of the original points is 0.10 metres RMSE.
- The planimetric data was obtained from the City of Mississauga in 2017.
- The vertical datum is mean sea level established by the CGVD 28, 1978 Southern Ontario adjustment.
- The horizontal datum is North American Datum 1983 CSRS (Epoch 2010) UTM Zone 17.
- To obtain City of Mississauga datum, add 0.121 metres to elevation data.
- Where section numbers are marked with an * the Regulatory flood elevations drop moving upstream. The flood elevation for Regulatory purposes shall be calculated by linearly interpolating between the upstream and downstream sections that are adjacent to the sections marked with an *. In no case shall interpolation extend through a structure. For additional clarification please contact Credit Valley Conservation.



No	Amendment/Revision	By	Date

FLOOD HAZARD MAP

CLEARVIEW CREEK WATERSHED

LEGEND

Bridges.....	Municipal Boundary.....	Wall.....
Building.....	Overhead Walkway.....	Watershed Boundary.....
Building Ruin.....	Parcel Fabric.....	Waterbody Elevation.....	+97.5
Building Under Construction.....	UC	Parking Lot.....	P/A	Wooded Area.....
Contour Index.....	172	Pipe.....	P	Regulatory Floodline.....
Contour Intermediate.....	172.5	Pit.....	Regulatory Floodplain (2D Model).....
Culvert Symbol.....	Playground.....	PLAY	1D-2D Model Limits.....	1D <-> 2D
Culvert to Scale.....	Pole.....	Two-Zone Policy Area.....
Dam.....	Pool.....	Section.....
Ditch.....	Railway.....	Overflow Section.....
Dock, Wharf, Pier.....	Railway Abandoned.....	Structure ID.....	10
Driveway.....	Road.....	Spill.....
Falls, Rapids.....	Rapid Falls	Road Understruction (UC).....	UC	Regional Flood Elevation	15426
Flow Direction.....	Sidewalk.....	Section Number	98.75
Footbridge.....	Silo.....	100 Year Flood Elevation	98.25
Guideroil.....	Spot Height.....	+123.45		
Headwall.....	Trail.....		
Hedge.....				
Marsh.....				

Note: The Regulatory flood elevation and floodline is the greater of the Regional and 100 Year storms. See General Note 6 concerning Section Numbers marked with an *.

SHEET INDEX

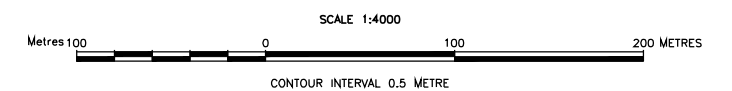
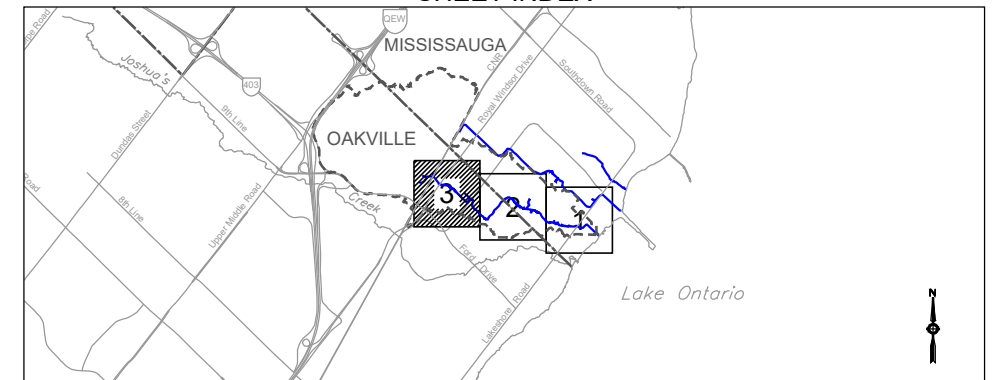

General Notes:

- Contourlines on this map were generated by Airborne Imaging using the Spring of 2015 LIDAR point cloud, breaklines and hydrologic enforcement of bridges. The vertical accuracy of the original points is 0.10 metres RMSE.
- The planimetric data was obtained from the City of Mississauga in 2017.
- The vertical datum is mean sea level established by the CGVD 28, 1978 Southern Ontario adjustment.
- The horizontal datum is North American Datum 1983 CSRS (Epoch 2010) UTM Zone 17.
- To obtain City of Mississauga datum, add 0.121 metres to elevation data.
- Where section numbers are marked with an * the Regulatory flood elevations drop moving upstream. The flood elevation for Regulatory purposes shall be calculated by linearly interpolating between the upstream and downstream sections that are adjacent to the sections marked with an *. In no case shall interpolation extend through a structure. For additional clarification please contact Credit Valley Conservation.



No	Amendment/Revision	By	Date

4.3 Stormwater Management for the Park Mount Development

4.3.1. Existing and Future Flows

Existing conditions and post-development flows, with and without a stormwater management pond were calculated for the study subcatchment containing the Park Mount Development. All flows were calculated using the 4-hour Chicago Storm distribution. The NASH Hydrograph method was used to calculate the existing conditions flows and the StandHyd method was used to calculate the future conditions flows.

Table 13 presents the pre-development and post-development flows and runoff volumes for Subcatchment 5 (total area 24.2 ha) that includes the Park Mount Property (approximately 14.5 ha development area not including the creek realignment corridor). Numbers in brackets show the flow contribution from the Park Mount Development area of 14.5 ha.

Table 13 Post-development and Pre-development Flows for Park Mount Development Subcatchment

Storm Recurrence (Years)	Pre-development Runoff		Uncontrolled Post-development Runoff		Post-development Runoff with Stormwater Management Pond in Park Mount Development	
	Flow (m ³ /s)	Volume (m ³)	Flow (m ³ /s)	Volume (m)	Flow (m ³ /s)	Volume (m ³)
2	0.15 (0.10)	1300 (780)	1.74 (1.73)	3840 (3470)	0.08 (0.04)	3840 (3470)
5	0.30 (0.19)	2390 (1430)	2.57 (2.56)	5540 (4830)	0.24 (0.17)	5540 (4830)
10	0.42 (0.27)	3250 (1950)	3.16 (3.15)	6740 (5780)	0.40 (0.31)	6740 (5780)
25	0.58 (0.37)	4460 (2680)	3.99 (3.99)	8360 (7010)	0.55 (0.37)	8360 (7010)
50	0.71 (0.45)	5350 (3200)	4.58 (4.57)	9480 (7850)	0.56 (0.45)	9480 (7850)
100	0.84 (0.54)	6320 (3790)	5.17 (5.16)	10680 (8730)	0.74 (0.54)	10680 (8730)

4.3.2. Stormwater Management Pond

The proposed extended detention SWM wet pond for the Park Mount Development will provide an Enhanced (Level 1) level of treatment, which exceeds the specified Normal (Level 2) target for water quality treatment in the study watershed. The Enhanced level of treatment will provide an added benefit to upstream and downstream users by releasing cleaner post-development flows to the creek thus enhancing the overall water quality in the creek.

The estimated preliminary parameters for the required stormwater pond are summarized in Table 14. The volumes of the permanent pool, the extended detention, and flood attenuation zones were calculated using the criteria discussed in Section 4.2.1, with the exception for water quality, where a higher standard was used. As summarized in Table 14, 202 m³/ha was used for water quality control, which is based on 80 % impervious area and the Enhanced level of protection, according to criteria in MOE guidelines. The extended detention volume of 210 m³/ha was calculated based on the volume of runoff generated by 25mm of precipitation and the weighted runoff coefficient of 0.84 for the development area. The combined extended detention and flood attenuation volume is the required detention storage to reduce the 2 year to 100-year post-

6.0 IMPLEMENTATION AND MONITORING PLAN

The implementation and monitoring plan encompasses two different components, specifically, the more detailed and intensive but shorter term monitoring associated with a development proposal or specific construction activity that will change the land use or landscape in one area of the watershed, and the more general long term monitoring undertaken across the watershed as a whole. The development or activity specific monitoring would be undertaken by the developer/proponent, with reporting and review requirements to the Town and CVC. The long term overall monitoring program would be undertaken by the Town and / or CVC.

6.1 Development / Activity Monitoring

The development / activity driven monitoring should follow three stages: the pre-development phase, the construction phase, and the post-construction phase. During the pre-development phase, monitoring should be undertaken to generate any additional baseline data that may be required to compile a more detailed understanding of existing conditions. In the construction phase the purpose of monitoring will be to ensure that the environmental measures implemented during construction are performing as expected (i.e. sediment control by provision of silt fences and temporary sediment traps/basins). Monitoring during the post-construction phase will be conducted to confirm that the performance targets are being achieved and to ensure that no negative environmental changes are occurring because of development.

For the study watershed, the areas of critical importance include impacts of development on water quality and peak flows, potential point soil contamination (on-going issue) and monitoring of the proposed channel re-location and associated stream and riparian corridor habitat elements. Soil contamination is an issue due to the industrial nature of the existing and proposed developments within the subwatershed.

6.2 Stormwater Management Implementation and Monitoring Plan

The preferred option for treatment of stormwater in the study subwatershed is based on the use of 'wet detention ponds'. Where ponds cannot be provided due to existing space/land purchase negotiations the use of flat bottom grassed swales is recommended. The approximate capital cost of construction of the three SWM extended detention wet ponds is approximately \$1,050,000. The cost of construction of grassed swales by modification of existing ditches and provision of sediment control BMPs would be in the order of \$400,000.

During Construction Monitoring Program

During construction, the monitoring program of the SWM facilities, including the temporary sediment control facilities such as excavated sediment traps, should include the following:

- Weekly inspections of the facilities.
- Inspections of the control facilities and the receiving watercourse, i.e. Clearview Creek, after rainfall events with at least 10 mm of precipitation.
- Measurement of suspended solids downstream of the control works.

Weekly inspection reports should be submitted by the developer's engineer to the satisfaction of the Town of Oakville. The reports should summarize the state of the control works, their performance during rainfall events, any presence of downstream erosion or sediment accumulation, and any actions necessary to modify the works.

Post-Construction Monitoring Program

The proponent will submit a Monitoring Response and Maintenance Program (MRM Program), which will be initiated upon completion of the 'During Construction Monitoring Program', and will extend for a 2 year period following substantial completion. A typical monitoring season should extend from mid-April to end of October, with specific monitoring during the off-construction season following major runoff events to ensure long term or over-wintering measures remain stable. The substantial completion requires that for a given development all roads and open spaces be completed and 90% of lots sodded. The program should focus on compliance with watershed targets as well as ecological health immediately downstream of the development. The program should identify the following:

- **Performance Targets.** The following specifies allowable targets for flood control, allowable sediment levels, temperature and other targets relating to water quality:
 - Flood Control Target - SWM pond outflows to be controlled to pre-development levels up to the 100 year event.
 - Sediment Control Target: Background Annual Average.
 - Temperature of SWM pond discharge to Clearview Creek: Background Maximum - Conditional on Air Temperature.
 - Dissolved Oxygen: Background Annual Average.
 - Other water quality parameters: Background Annual Average Levels
 - Total Phosphorous, Nitrate, Chlorides, E.coli, Aluminum, Copper, Total ammonia (unionized NH₃)

The exceedance of any of the identified target levels will represent triggers, which will immediately initiate the Response Plan.

- **Mitigation Measures.** If targets are not met mitigation measures should be implemented. Possible mitigation measures will be identified in the MRM Program, along with approximate costs and expected benefits.
- **Response Plan,** which will be implemented where the monitoring identifies that Performance Targets are not being met. The Response Plan may include more comprehensive monitoring program to determine the consequence of exceedance.
- **Maintenance Requirements.** Routine and occasional maintenance requirements will be identified for the SWM facilities.
- **Monitoring Program,** which at the minimum should include the items listed below. Recommendations for remediation should be made where required.

- a. Collect water level from SWM facilities during the monitoring season.
- b. Collect water quality data (suspended solids, dissolved oxygen, phosphorous) as per Section 6.2 during the same five significant rainfall events specified in Section 6.2.1.
- c. During the spring and fall, inspect all SWM facilities shortly after a rainfall event to determine whether the outlet works operate as designed. Make recommendations
- d. Groundwater elevation and quality monitoring
- e. Twice annually inspect the health of the vegetation at existing SWM facilities
- f. Inspect annually the boundary between developed areas and natural areas/buffers.
- g. Cleanup litter and notify the Town of Oakville of illicit dumping.

The Monitoring Reports should be submitted twice per year to the Town of Oakville and CVC. The reports will present the results of monitoring of the SWM facilities, note trends, exceedance of performance targets, comment on the effectiveness of the SWM facilities and recommend mitigation measures where required.

- **Erosion Control.** Two or more erosion monitoring stations should be established on Clearview Creek downstream of the proposed development to monitor the amount of erosion during construction and in the post-construction period. The selected sites should contain a section where erosion is evident as well as a section which does not show erosion but is prone to erosion (i.e. creek bend). Each station should be inspected annually and any changes in bed or banks should be noted. A photographic inventory should be maintained at selected sites, which should be updated after each inspection.

6.2.1. Water Quality Testing Frequency and Locations

A total of eight water quality sampling runs per year will be conducted at two locations over a three-year period. Five of these sampling runs will be conducted during significant rain events and three sampling runs will be conducted during dry weather conditions (negligible precipitation in the previous five days). The sampling frequency should be evenly distributed throughout the open water season from April to October. The recommended water chemistry sampling locations are:

1. Downstream of Royal Windsor Road
2. Upstream of Winston Churchill Blvd at the property boundary at the downstream end of stream re-alignment

The recommended water sampling program is as follows:

Year 1 - Baseline monitoring, prior to site development. Eight samples are to be taken at the two locations and the samples will be tested for the above-identified parameters.

Years 2 and 3 - Post-construction monitoring, to be conducted after completion of site development. Eight samples are to be taken during each year at the two locations and the samples will be tested for the above-identified parameters.

MODIFIED: Jun. 03, 2014 9:08 AM

DRAWING NAME: K:\DRAWINGS\6400-6556-6556-CLEARVIEW CREEK REALIGNMENT\DRAINAGE\CNR RELIEF DITCH\6556-CLEARVIEW CREEK-HEC-PAS SECTION LOCATIONS-INTERM WITH CNF RELIEF CHANNEL.DWG

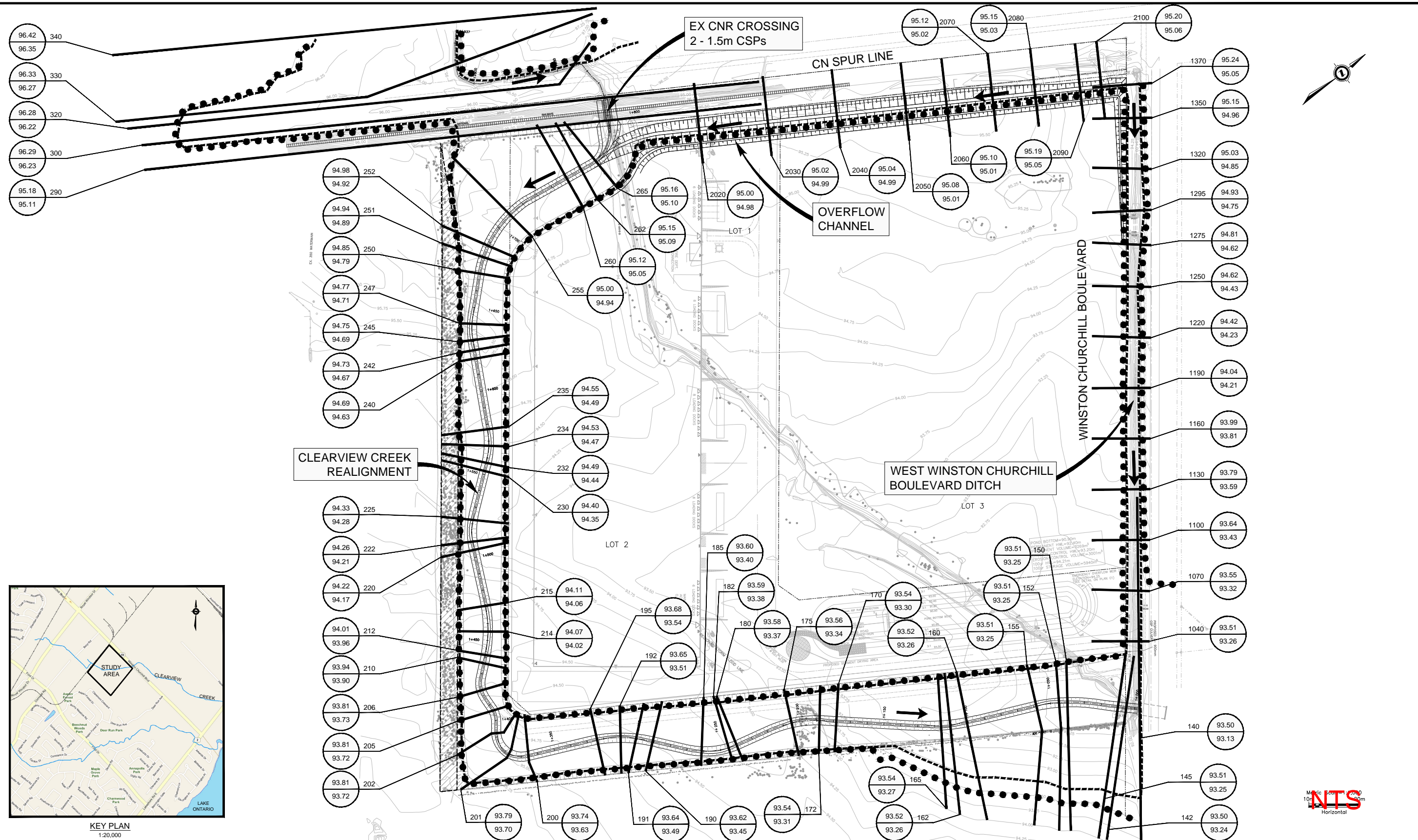

KEY PLAN
1:20,000

LEGEND

- INTERIM REGIONAL FLOODLINE
- INTERIM 100 YEAR FLOODLINE
- INTERIM REGIONAL STORM ELEVATION SECTION NUMBER
- 100 YEAR FLOOD ELEVATION

INTERIM CONDITIONS SECTION LOCATIONS AND REGIONAL STORM FLOODLINES

CLEARVIEW CREEK REALIGNMENT AND SITE WORK
772 WINSTON CHURCHILL BOULEVARD
OAKVILLE, ONTARIO

IGRI Advisors Inc.

8.	CN FLOOD RELIEF (OVERFLOW) CHANNEL	JUNE 14
7.	FOR CVC PERMIT	JUNE 12
6.	ADDRESSED CVC COMMENTS	APR. 12
5.	ADDRESSED CVC COMMENTS	NOV. 11
4.	ADDRESSED CVC COMMENTS	MAY 11
3.	ADDRESSED CVC COMMENTS	FEB. 11
2.	ADDRESSED CVC COMMENTS	APR. 09
1.	L.O.I.	JULY 08
No.	Revision/Issue	Date



Project No.:	6556-0100	Date:	JUNE 2014
Scale:	AS SHOWN	Revision	Drawing
Dwn. By.:	J.J./J.S.	8	10
Dsgn. By.:	J.B.		
Chkd. By.:	J.C.		



```

=====
SSSSS W W M M H H Y Y M M OOO          999 999 =====
S      W W W MM MM H H Y Y MM MM O O      9 9 9 9
SSSSS W W W M M M HHHHH Y M M M O O ## 9 9 9 9 Ver. 4.02
      S W W M M H H Y M M O O          9999 9999 July 1999
SSSSS W W M M H H Y M M OOO          9 9 =====
                                           9 9 9 9 # 3813174
StormWater Management HYdrologic Model    999 999 =====

```

```

*****
***** SWMHYMO-99 Ver/4.02 *****
***** A single event and continuous hydrologic simulation model *****
***** based on the principles of HYMO and its successors *****
***** OTTHYMO-83 and OTTHYMO-89. *****
***** Distributed by: J.F. Sabourin and Associates Inc. *****
***** Ottawa, Ontario: (613) 727-5199 *****
***** Gatineau, Quebec: (819) 243-6858 *****
***** E-Mail: swmhymo@jfsa.Com *****
*****

```

```

+++++++
+++++++ Licensed user: A.M. Candaras Associates Inc. ++++++
+++++++ Woodbridge SERIAL#:3813174 ++++++
+++++++

```

```

*****
***** +++++ PROGRAM ARRAY DIMENSIONS +++++ *****
***** Maximum value for ID numbers : 10 *****
***** Max. number of rainfall points: 15000 *****
***** Max. number of flow points : 15000 *****
*****

```

```

***** D E T A I L E D O U T P U T *****
*****
* DATE: 2021-01-22 TIME: 14:27:53 RUN COUNTER: 000203 *
* Input filename: C:\PROGRA-1\SWMHYMO\PROJECTS\2060\2060Pre.dat *
* Output filename: C:\PROGRA-1\SWMHYMO\PROJECTS\2060\2060Pre.out *
* Summary filename: C:\PROGRA-1\SWMHYMO\PROJECTS\2060\2060Pre.sum *
* User comments: *
* 1: _____ *
* 2: _____ *
* 3: _____ *
*****

```

```

-----
001:0001-----
## *****
## Project Name: 772 Winston Churchill Blvd., Oakville
## Project Number: 2060
## Date : 2021-01-22
## Modeller : F. Petkovski, P.Eng.
## Company : a.m. candaras associates inc.
## License # : 3813174
## *****

```

```

| START | Project dir.: C:\PROGRA-1\SWMHYMO\PROJECTS\2060\

```

```

----- Rainfall dir.: C:\PROGRA-1\SWMHYMO\PROJECTS\2060\
TZERO = .00 hrs on 0
METOUT= 2 (output = METRIC)
NRUN = 001
NSTORM= 1
# 1=CHIC2YR.STM

```

```

001:0002-----
*

```

```

| READ STORM | Filename: C:\PROGRA-1\SWMHYMO\PROJECTS\2060\CHIC2Y
| Ptotal= 34.80 mm | Comments: *BLOOR ST STAT DATA 10 MIN DISCRITIZATIO

```

TIME	RAIN	TIME	RAIN	TIME	RAIN	TIME	RAIN
hrs	mm/hr	hrs	mm/hr	hrs	mm/hr	hrs	mm/hr
.08	2.260	1.08	17.100	2.08	5.270	3.08	2.700
.17	2.260	1.17	17.100	2.17	5.270	3.17	2.700
.25	2.580	1.25	81.810	2.25	4.500	3.25	2.510
.33	2.580	1.33	81.810	2.33	4.500	3.33	2.510
.42	3.020	1.42	22.530	2.42	3.950	3.42	2.350
.50	3.020	1.50	22.530	2.50	3.950	3.50	2.350
.58	3.690	1.58	11.900	2.58	3.520	3.58	2.210
.67	3.690	1.67	11.900	2.67	3.520	3.67	2.210
.75	4.830	1.75	8.250	2.75	3.190	3.75	2.090
.83	4.830	1.83	8.250	2.83	3.190	3.83	2.090
.92	7.240	1.92	6.400	2.92	2.920	3.92	1.980
1.00	7.240	2.00	6.400	3.00	2.920	4.00	1.980

```

-----
001:0003-----
*****
* SUB-CATCHMENT 5 - PRE-DEVELOPMENT FLOW RATES
* BASED ON AREA OF 24.2 ha
*****

```

```

| CALIB NASHYD | Area (ha)= 24.20 Curve Number (CN)=70.00
| 01:000100 DT= 5.00 | Ia (mm)= 7.000 # of Linear Res.(N)= 3.00
----- U.H. Tp(hrs)= .820

```

```

Unit Hyd Qpeak (cms)= 1.127
PEAK FLOW (cms)= .155 (i)
TIME TO PEAK (hrs)= 2.417
RUNOFF VOLUME (mm)= 5.655
TOTAL RAINFALL (mm)= 34.800
RUNOFF COEFFICIENT = .163

```

```

(i) PEAK FLOW DOES NOT INCLUDE BASEFLOW IF ANY.

```

```

-----
001:0004-----
*****
** END OF RUN : 1

```

```

*****

```

START Project dir.: C:\PROGRA-1\SWMHYMO\PROJECTS\2060\
Rainfall dir.: C:\PROGRA-1\SWMHYMO\PROJECTS\2060\
TZERO = .00 hrs on 0
METOUT= 2 (output = METRIC)
NRUN = 002
NSTORM= 1
1=CHIC5YR.STM

002:0002-
Project Name: 772 Winston Churchill Blvd., Oakville
Project Number: 2060
Date : 2021-01-22
Modeller : F. Petkovski, P.Eng.
Company : a.m. candaras associates inc.
License # : 3813174

002:0002-
READ STORM Filename: C:\PROGRA-1\SWMHYMO\PROJECTS\2060\CHIC5Y
Pttotal= 46.25 mm| Comments: *BLOOR ST STAT DATA 10 MIN DISCRITIZATIO

Table with 8 columns: TIME, RAIN, TIME, RAIN, TIME, RAIN, TIME, RAIN. Rows show rainfall data in hrs and mm/hr for various time intervals.

002:0003-
SUB-CATCHMENT 5 - PRE-DEVELOPMENT FLOW RATES
BASED ON AREA OF 24.2 ha

CALIB NASHYD Area (ha)= 24.20 Curve Number (CN)=70.00
01:000100 DT= 5.00 Ia (mm)= 7.000 # of Linear Res.(N)= 3.00
U.H. Tp(hrs)= .820

Unit Hyd Qpeak (cms)= 1.127
PEAK FLOW (cms)= .300 (i)
TIME TO PEAK (hrs)= 2.417
RUNOFF VOLUME (mm)= 10.402
TOTAL RAINFALL (mm)= 46.250
RUNOFF COEFFICIENT = .225

(i) PEAK FLOW DOES NOT INCLUDE BASEFLOW IF ANY.

002:0004-
002:0002-
** END OF RUN : 2

START Project dir.: C:\PROGRA-1\SWMHYMO\PROJECTS\2060\
Rainfall dir.: C:\PROGRA-1\SWMHYMO\PROJECTS\2060\
TZERO = .00 hrs on 0
METOUT= 2 (output = METRIC)
NRUN = 003
NSTORM= 1
1=CHIC10YR.STM

003:0002-
Project Name: 772 Winston Churchill Blvd., Oakville
Project Number: 2060
Date : 2021-01-22
Modeller : F. Petkovski, P.Eng.
Company : a.m. candaras associates inc.
License # : 3813174

003:0002-
READ STORM Filename: C:\PROGRA-1\SWMHYMO\PROJECTS\2060\CHIC10
Pttotal= 54.14 mm| Comments: *BLOOR ST STAT DATA 10 MIN DISCRITIZATIO

Table with 8 columns: TIME, RAIN, TIME, RAIN, TIME, RAIN, TIME, RAIN. Rows show rainfall data in hrs and mm/hr for various time intervals.

003:0003-
SUB-CATCHMENT 5 - PRE-DEVELOPMENT FLOW RATES
BASED ON AREA OF 24.2 ha

CALIB NASHYD Area (ha)= 24.20 Curve Number (CN)=70.00
01:000100 DT= 5.00 Ia (mm)= 7.000 # of Linear Res.(N)= 3.00
U.H. Tp(hrs)= .820

Unit Hyd Qpeak (cms)= 1.127
PEAK FLOW (cms)= .413 (i)
TIME TO PEAK (hrs)= 2.333
RUNOFF VOLUME (mm)= 14.245
TOTAL RAINFALL (mm)= 54.140
RUNOFF COEFFICIENT = .263

(i) PEAK FLOW DOES NOT INCLUDE BASEFLOW IF ANY.

003:0004-----

003:0002-----

003:0002-----
** END OF RUN : 3

START Project dir.: C:\PROGRA~1\SWMHYMO\PROJECTS\2060\
Rainfall dir.: C:\PROGRA~1\SWMHYMO\PROJECTS\2060\
TZERO = .00 hrs on 0
METOUT= 2 (output = METRIC)
NRUN = 004
NSTORM= 1
1=CHIC25YR.STM

004:0002-----
##*****
Project Name: 772 Winston Churchill Blvd., Oakville
Project Number: 2060
Date : 2021-01-22
Modeller : F. Petkovski, P.Eng.
Company : a.m. candaras associates inc.
License # : 3813174
##*****

004:0002-----
*

READ STORM Filename: C:\PROGRA~1\SWMHYMO\PROJECTS\2060\CHIC25
Ptotal= 62.16 mm Comments: *BLOOR ST STAT DATA 10 MIN DISCRITIZATIO

Table with 8 columns: TIME, RAIN, TIME, RAIN, TIME, RAIN, TIME, RAIN. Rows show rainfall data at 0.08, 0.17, and 0.25 hour intervals.

Table with 8 columns: TIME, RAIN, TIME, RAIN, TIME, RAIN, TIME, RAIN. Rows show rainfall data at 0.33, 0.42, 0.50, 0.58, 0.67, 0.75, 0.83, 0.92, and 1.00 hour intervals.

004:0003-----

* SUB-CATCHMENT 5 - PRE-DEVELOPMENT FLOW RATES
* BASED ON AREA OF 24.2 ha

CALIB NASHYD Area (ha)= 24.20 Curve Number (CN)=70.00
01:000100 DT= 5.00 Ia (mm)= 7.000 # of Linear Res.(N)= 3.00
U.H. Tp(hrs)= .820

Unit Hyd Qpeak (cms)= 1.127

PEAK FLOW (cms)= .540 (i)
TIME TO PEAK (hrs)= 2.333
RUNOFF VOLUME (mm)= 18.550
TOTAL RAINFALL (mm)= 62.158
RUNOFF COEFFICIENT = .298

(i) PEAK FLOW DOES NOT INCLUDE BASEFLOW IF ANY.

004:0004-----

004:0002-----

004:0002-----

004:0002-----
** END OF RUN : 4

START Project dir.: C:\PROGRA~1\SWMHYMO\PROJECTS\2060\
Rainfall dir.: C:\PROGRA~1\SWMHYMO\PROJECTS\2060\
TZERO = .00 hrs on 0
METOUT= 2 (output = METRIC)
NRUN = 005
NSTORM= 1
1=CHIC50YR.STM

005:0002-----
##*****

Project Name: 772 Winston Churchill Blvd., Oakville

*# Project Number: 2060
*# Date : 2021-01-22
*# Modeller : F. Petkovski, P.Eng.
*# Company : a.m. candaras associates inc.
*# License # : 3813174

005:0002-----
*

READ STORM Filename: C:\PROGRA-1\SWMHYMO\PROJECTS\2060\CHIC50
Ptotal= 70.32 mm Comments: *BLOOR ST STAT DATA 10 MIN DISCRITIZATIO

Table with 8 columns: TIME hrs, RAIN mm/hr, TIME hrs, RAIN mm/hr, TIME hrs, RAIN mm/hr, TIME hrs, RAIN mm/hr. Rows show rainfall data from 0.08 to 1.00 hours.

005:0003-----

* SUB-CATCHMENT 5 - PRE-DEVELOPMENT FLOW RATES
* BASED ON AREA OF 24.2 ha

CALIB NASHYD Area (ha)= 24.20 Curve Number (CN)=70.00
01:000100 DT= 5.00 Ia (mm)= 7.000 # of Linear Res.(N)= 3.00
U.H. Tp(hrs)= .820

Unit Hyd Qpeak (cms)= 1.127
PEAK FLOW (cms)= .706 (i)
TIME TO PEAK (hrs)= 2.333
RUNOFF VOLUME (mm)= 23.284
TOTAL RAINFALL (mm)= 70.316
RUNOFF COEFFICIENT = .331

(i) PEAK FLOW DOES NOT INCLUDE BASEFLOW IF ANY.

005:0004-----

005:0002-----

005:0002-----

005:0002-----

005:0002-----

** END OF RUN : 5

START Project dir.: C:\PROGRA-1\SWMHYMO\PROJECTS\2060\
Rainfall dir.: C:\PROGRA-1\SWMHYMO\PROJECTS\2060\

TZERO = .00 hrs on 0
METOUT= 2 (output = METRIC)
NRUN = 006
NSTORM= 1
1=CH100YR.STM

006:0002-----

*# Project Name: 772 Winston Churchill Blvd., Oakville
*# Project Number: 2060
*# Date : 2021-01-22
*# Modeller : F. Petkovski, P.Eng.
*# Company : a.m. candaras associates inc.
*# License # : 3813174

006:0002-----
*

READ STORM Filename: C:\PROGRA-1\SWMHYMO\PROJECTS\2060\CH100Y
Ptotal= 78.03 mm Comments: *BLOOR ST STAT DATA 10 MIN DISCRITIZATIO

Table with 8 columns: TIME hrs, RAIN mm/hr, TIME hrs, RAIN mm/hr, TIME hrs, RAIN mm/hr, TIME hrs, RAIN mm/hr. Rows show rainfall data from 0.08 to 1.00 hours.

006:0003-----

* SUB-CATCHMENT 5 - PRE-DEVELOPMENT FLOW RATES
* BASED ON AREA OF 24.2 ha

CALIB NASHYD Area (ha)= 24.20 Curve Number (CN)=70.00
01:000100 DT= 5.00 Ia (mm)= 7.000 # of Linear Res.(N)= 3.00
U.H. Tp(hrs)= .820

Unit Hyd Qpeak (cms)= 1.127

PEAK FLOW (cms)= .869 (i)
TIME TO PEAK (hrs)= 2.333
RUNOFF VOLUME (mm)= 28.048
TOTAL RAINFALL (mm)= 78.032
RUNOFF COEFFICIENT = .359

(i) PEAK FLOW DOES NOT INCLUDE BASEFLOW IF ANY.

006:0004-----

006:0002-----
006:0002-----
006:0002-----
006:0002-----
006:0002-----
** END OF RUN : 6

START | Project dir.: C:\PROGRA~1\SWMHYMO\PROJECTS\2060\
Rainfall dir.: C:\PROGRA~1\SWMHYMO\PROJECTS\2060\
TZERO = .00 hrs on 0
METOUT= 2 (output = METRIC)
NRUN = 007
NSTORM= 1
1=CHIC25MM.STM

007:0002-----
##*****
Project Name: 772 Winston Churchill Blvd., Oakville
Project Number: 2060
Date : 2021-01-22
Modeller : F. Petkovski, P.Eng.
Company : a.m. candaras associates inc.
License # : 3813174
##*****

007:0002-----
*
READ STORM | Filename: C:\PROGRA~1\SWMHYMO\PROJECTS\2060\CHIC25
Ptotal= 25.00 mm | Comments: *BLOOR ST STAT DATA 10 MIN DISCRITIZATIO

Table with 8 columns: TIME, RAIN, TIME, RAIN, TIME, RAIN, TIME, RAIN. Values include .08, .17, .25 for time and 1.624, 1.853 for rain.

Table with 8 columns: .33, .42, .50, .58, .67, .75, .83, .92, 1.00 for time and 1.853, 2.170, 2.170, 2.651, 2.651, 3.470, 3.470, 5.201, 5.201 for rain.

007:0003-----

* SUB-CATCHMENT 5 - PRE-DEVELOPMENT FLOW RATES
* BASED ON AREA OF 24.2 ha

CALIB NASHYD | Area (ha)= 24.20 | Curve Number (CN)=70.00
01:000100 DT= 5.00 | Ia (mm)= 7.000 | # of Linear Res.(N)= 3.00
U.H. Tp(hrs)= .820
Unit Hyd Qpeak (cms)= 1.127
PEAK FLOW (cms)= .067 (i)
TIME TO PEAK (hrs)= 2.583
RUNOFF VOLUME (mm)= 2.554
TOTAL RAINFALL (mm)= 25.000
RUNOFF COEFFICIENT = .102

(i) PEAK FLOW DOES NOT INCLUDE BASEFLOW IF ANY.

007:0004-----

007:0002-----
007:0002-----
007:0002-----
007:0002-----
007:0002-----
FINISH

WARNINGS / ERRORS / NOTES
Simulation ended on 2021-01-22 at 14:27:53

**APPENDIX B
STORMWATER DESIGN
CALCULATIONS**

ROOFTOP STORAGE AVAILABLE CALCULATIONS

Table 1A – Building A Roof Storage Required for 100-Year Storm Event

TIME PERIOD (min)	INTENSITY (mm/hr)	RUNOFF (l/s)	STORAGE (m ³)
20-30	4.96	38.3	0.0
30-40	5.88	45.4	0.0
40-50	7.27	56.2	0.0
50-60	9.69	74.9	0.0
60-70	15.00	115.9	0.0
70-80	38.04	293.9	105.6
80-90	203.31	1571.0	871.8
90-100	51.04	394.4	165.8
100-110	25.59	197.7	47.8
110-120	17.24	133.2	9.1
120-130	13.11	101.3	0.0
130-140	10.64	82.2	0.0
140-150	8.99	69.5	0.0
150-160	7.81	60.3	0.0
160-170	6.92	53.5	0.0
			1,200.2

Building A Roof: = 30,906 m² @ C = 0.90

CAN = $\frac{[(30,906 \times 0.90) \times 2.778]}{10,000}$
 = 7.727

Runoff = CAN

Storage (m³): = $\frac{(\text{Runoff} - \text{Roof Outflow}) \times 5 \text{ min} \times 60 \text{ sec}}{1,000}$

Max. Outflow = 118.0 l/s @ 150mm Depth

Table 1B – Building B Roof Storage Required for 100-Year Storm Event

TIME PERIOD (min)	INTENSITY (mm/hr)	RUNOFF (l/s)	STORAGE (m ³)
30-40	5.88	42.9	0.0
40-50	7.27	53.1	0.0
50-60	9.69	70.7	98.1
60-70	15.00	109.5	822.1
70-80	38.04	277.7	155.1
80-90	203.31	1484.4	43.6
90-100	51.04	372.7	7.0
100-110	25.59	186.8	0.0
110-120	17.24	125.9	0.0
120-130	13.11	95.7	0.0
130-140	10.64	77.7	0.0
140-150	8.99	65.6	0.0
150-160	7.81	57.0	0.0
160-170	6.92	50.5	0.0
			1,125.9

Building B Roof: = 29,203 m² @ C = 0.90

CAN = $\frac{[(29,203 \times 0.90) \times 2.778]}{10,000}$
 = 7.301

Runoff = CAN

Storage (m³): = $\frac{(\text{Runoff} - \text{Roof Outflow}) \times 5 \text{ min} \times 60 \text{ sec}}{1,000}$

Max. Outflow = 114.2 l/s @ 150mm Depth

ROOF PONDING DETAILS: BUILDINGS A & B

Criteria:

Building A: Roof Area = 30,906 m²

Total No. of Low Points = 38

Building B: Roof Area = 29,203 m²

Total No. of Low Points = 36

100 mm Ponding Depth

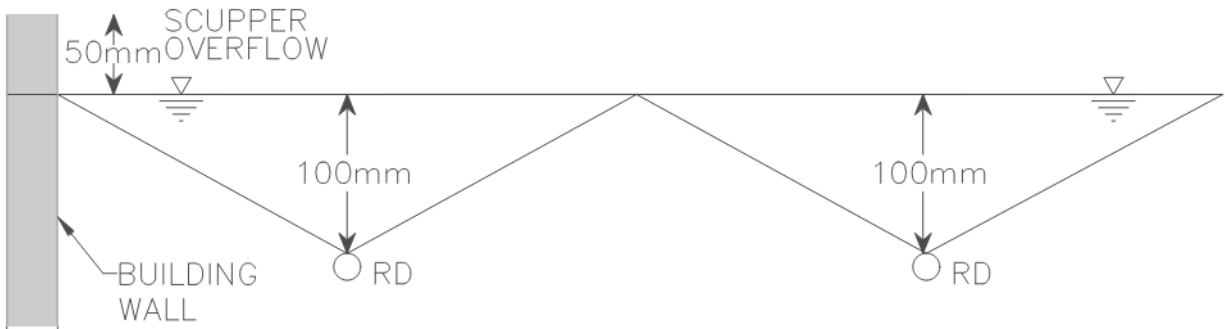

Building A Rooftop Ponding:

Refer to detailed calculations table and preliminary mechanical roof plan sketch.

$$\text{Available Ponding Volume per Low Point} = \frac{l \cdot w \cdot h}{3}$$

At 100mm Depth of Water

$$\text{Rooftop Volume Provided} = 1,053.6\text{m}^3$$

At 150mm Depth of Water

$$\text{Additional Volume} = 0.050\text{m} \times 30,900\text{m}^2 = 1,544.3 \text{ m}^3$$

$$\text{Total Rooftop Volume at 150mm Depth} = 1,053.6\text{m}^3 + 1,544.3\text{m}^3 = 2,597.9\text{m}^3$$

Building A - Stage-Storage-Discharge Relationship

Depth of Flow	Total Flows (l/s)	Total Volume (m ³)
0	0	0
100mm	71.3	1,053.6
125mm	94.6	1,825.8
150mm	118.0	2,597.9

Building B Rooftop Ponding:

Refer to detailed calculations table and preliminary mechanical roof plan sketch.

$$\text{Available Ponding Volume per Low Point} = \frac{l \cdot w \cdot h}{3}$$

At 100mm Depth of Water

$$\text{Rooftop Volume Provided} = 1,004.3\text{m}^3$$

At 150mm Depth of Water

$$\text{Additional Volume} = 0.050\text{m} \times 29,200\text{m}^2 = 1,460.0 \text{ m}^3$$

$$\text{Total Rooftop Volume at 150mm Depth} = 1,004.3\text{m}^3 + 1,460.0\text{m}^3 = 2,464.3\text{m}^3$$

Building B - Stage-Storage-Discharge Relationship

Depth of Flow	Total Flows (l/s)	Total Volume (m ³)
0	0	0
100mm	68.8	1,004.3
125mm	91.5	1,734.3
150mm	114.2	2,464.3

Combined Building A & B - Stage-Storage-Discharge Relationship ¹

Depth of Flow	Total Flows (l/s)	Total Volume (m ³)
0	0	0
100mm	140.1	2,057.9
125mm	186.1	3,560.1
150mm	232.2	5,062.2

1. Storage discharge relationship used as input in SWMHYMO route reservoir for roof top controls.

Engineering Specification

Job Name _____

Contractor _____

Job Location _____

Approval _____

Engineer _____

Contractor's P.O. No. _____

Approval _____

Representative _____

Tag _____

RD-100 Large Area Roof Drain Specification

Watts RD-100 epoxy coated cast iron roof drain with flashing clamp with integral gravel stop, self-locking polyethylene dome (standard), and no hub (standard) outlet.

Pipe Sizing		
Suffix	Description	
2	2"(51) Pipe Size (NH Only)	<input type="checkbox"/>
3	3"(76) Pipe Size	<input type="checkbox"/>
4	4"(102) Pipe Size	<input type="checkbox"/>
5	5"(127) Pipe Size (NH Only)	<input type="checkbox"/>
6	6"(152) Pipe Size	<input type="checkbox"/>



Outlet Type		
Suffix	Description	
NH	No Hub (MJ)	<input type="checkbox"/>
P	Push On	<input type="checkbox"/>
T	Threaded	<input type="checkbox"/>
X	Inside Caulk	<input type="checkbox"/>

Options		
Suffix	Description	
-13	Galvanized Body & Clamp	<input type="checkbox"/>
-A	Accutrol Flow Restrictor	<input type="checkbox"/>
-B	Sump Receiver	<input type="checkbox"/>
-D	Underdeck Clamp	<input type="checkbox"/>
-F	Deck Flange/Adj. Extension	<input type="checkbox"/>
-GSS	Stainless Steel Ballast Guard	<input type="checkbox"/>
-K	Ductile Iron Dome	<input type="checkbox"/>
-K13	Galvanized Dome	<input type="checkbox"/>
-K40	Ductile Iron Low Dome (4" High)	<input type="checkbox"/>
-K80	Aluminum Dome	<input type="checkbox"/>
-K81	Rough Bronze Dome	<input type="checkbox"/>
-K83	SS Mesh Covered Dome	<input type="checkbox"/>
-L	Vandal Proof Dome	<input type="checkbox"/>
-R	2" External Water Dam	<input type="checkbox"/>
-SO	Side Outlet (2", 3", 4" Only)	<input type="checkbox"/>
-V	Fixed Extension (2", 3", 4")	<input type="checkbox"/>
-W	Adjustable Internal Water Dam	<input type="checkbox"/>

Optional Body Material		
Suffix	Description	
-60	PVC Body w/Socket Outlet	<input type="checkbox"/>
-61	ABS Body w/Socket Outlet	<input type="checkbox"/>

**Deck Opening 10"(254)
with Sump Receiver 13 1/4"(337)**

Free Area
Sq. In.
137

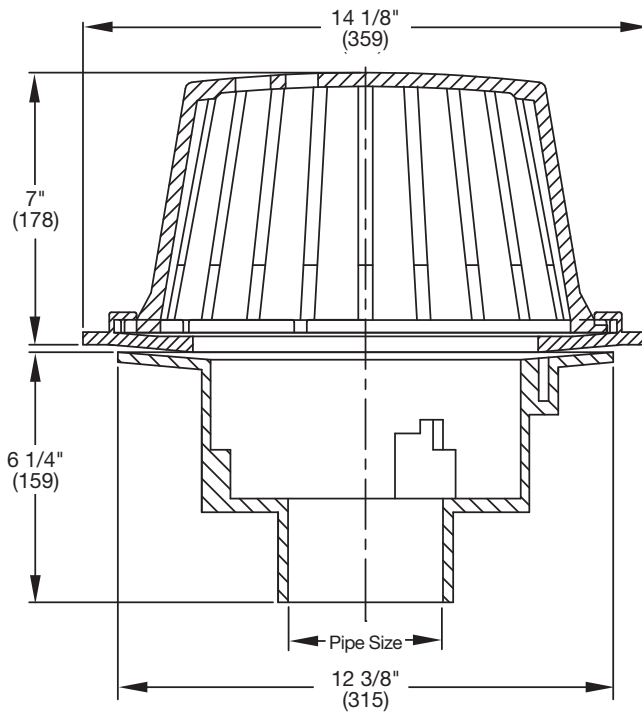

NOTICE

The information contained herein is not intended to replace the full product installation and safety information available or the experience of a trained product installer. You are required to thoroughly read all installation instructions and product safety information before beginning the installation of this product.

Watts product specifications in U.S. customary units and metric are approximate and are provided for reference only. For precise measurements, please contact Watts Technical Service. Watts reserves the right to change or modify product design, construction, specifications, or materials without prior notice and without incurring any obligation to make such changes and modifications on Watts products previously or subsequently sold.



USA: T: (800) 338-2581 • F: (828) 248-3929 • Watts.com

Canada: T: (888) 208-8927 • F: (905) 481-2316 • Watts.ca

Latin America: T: (52) 55-4122-0138 • Watts.com

NOTES:
 1. INTEGRAL SCREENING TO BE PROVIDED FOR ROOF TOP UNITS.
 2. RAIN WATER RELIEF SCUPPERS TO BE PLACED 50M APART MAX.
 3. ROOF DRAINS TO BE LOCATED 5M MAX. FROM EDGE OF ROOF AND 50M APART MAX. ON ROOF AREA FOR ROOF DRAIN TYPES SEE MECHANICAL DWGS.

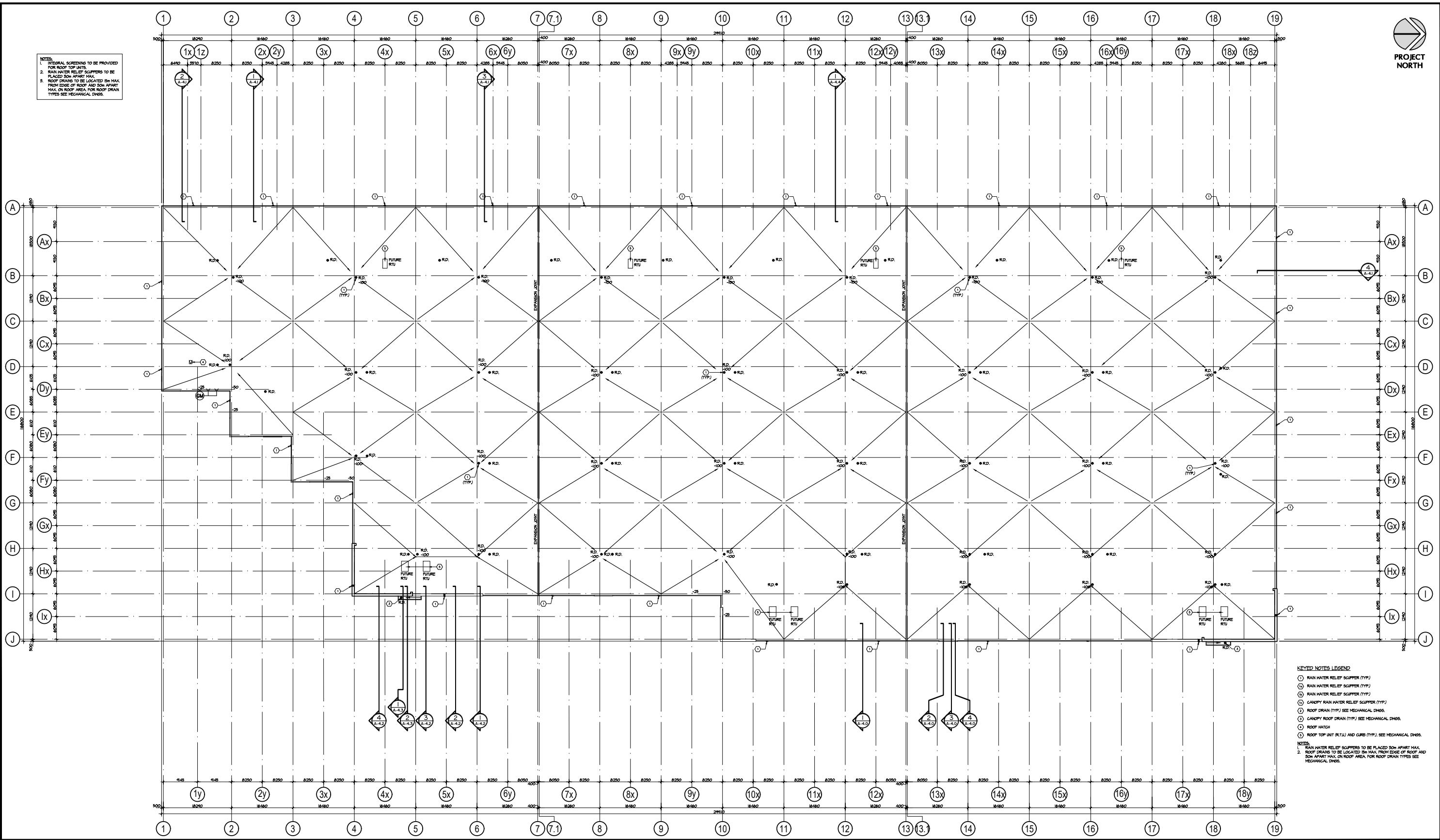

KEYED NOTES LEGEND

- ① RAIN WATER RELIEF SCUPPER (TYP)
- ② RAIN WATER RELIEF SCUPPER (TYP)
- ③ RAIN WATER RELIEF SCUPPER (TYP)
- ④ CANOPY RAIN WATER RELIEF SCUPPER (TYP)
- ⑤ ROOF DRAIN (TYP.) SEE MECHANICAL DWGS.
- ⑥ CANOPY ROOF DRAIN (TYP.) SEE MECHANICAL DWGS.
- ⑦ ROOF HATCH
- ⑧ ROOF TOP UNIT (RTU) AND CURB (TYP.), SEE MECHANICAL DWGS.

NOTES:
 1. RAIN WATER RELIEF SCUPPERS TO BE PLACED 50M APART MAX.
 2. ROOF DRAINS TO BE LOCATED 5M MAX. FROM EDGE OF ROOF AND 50M APART MAX. ON ROOF AREA FOR ROOF DRAIN TYPES SEE MECHANICAL DWGS.

03/27/21 772 Winston Churchill - Fengate/Design/01_Corner_Design/Building_A/277_A_A-2.1.dwg

No.	ISSUED	DATE
1	ISSUED FOR COORDINATION	MAR. 30, 2021
2	ISSUED FOR SPA	APR. 9, 2021
3	RE-ISSUED FOR SPA	DEC. 15, 2021

No.	REVISION	DATE

BALDASSARRA
 Architects Inc.

30 Great Gulf Drive, Unit 20 | Concord ON | L4K 0K7
 T. 905.660.0722 | www.baldassarra.ca

OWNERS INFORMATION:



FENGATE
 772 Winston Churchill Blvd.
 Oakville, Ontario

ROOF PLAN Building A

DATE: MAR. 2021 DRAWN BY: HP CHECKED: HP SCALE: NTS

PROJECT No. 22-77 A DRAWING No. **A-2.1**

NOTE: INTERNAL SCREENING TO BE PROVIDED FOR ROOF TOP UNITS.

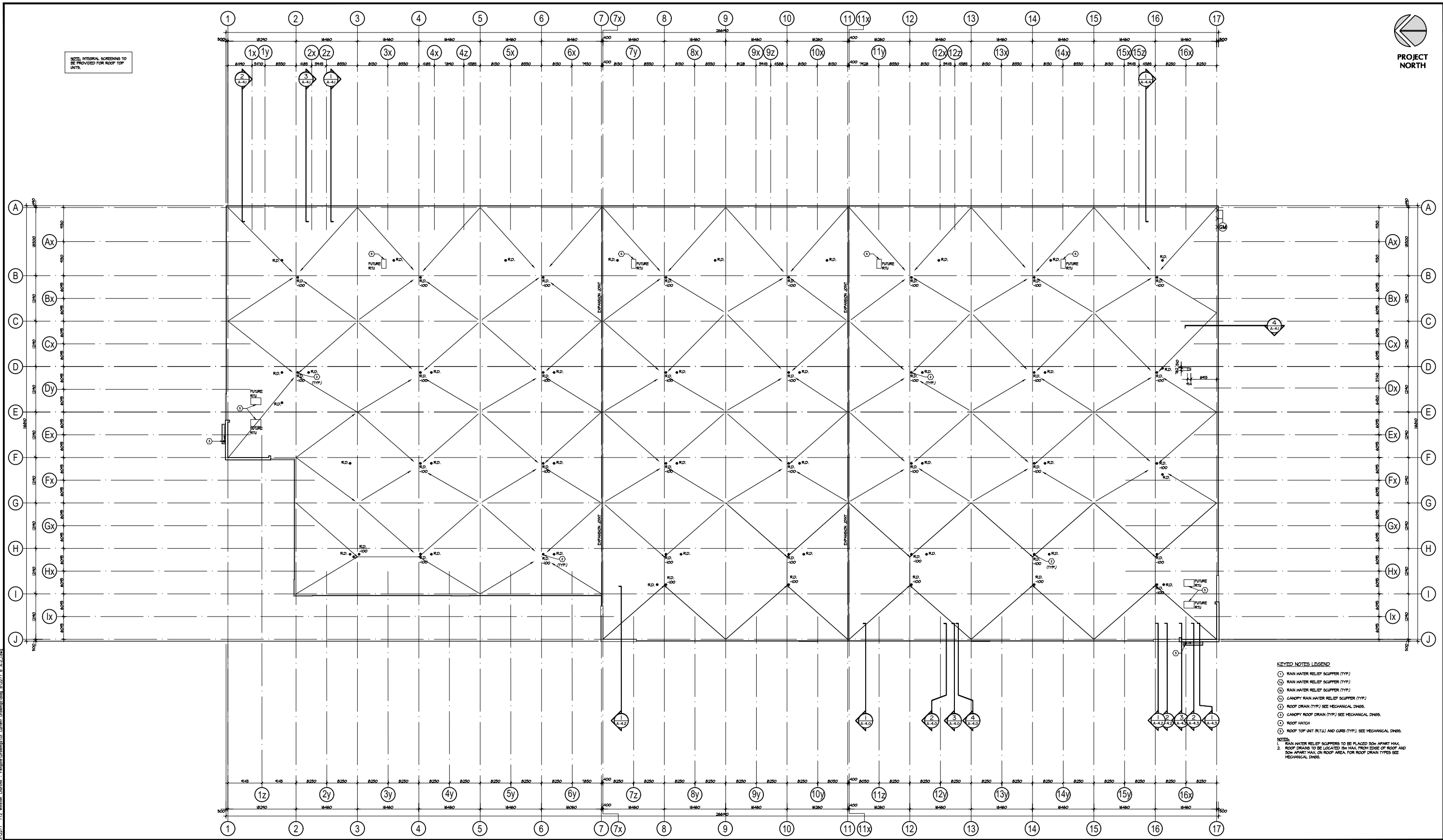

- KEYED NOTES LEGEND**
- ① RAIN WATER RELIEF SCUPPER (TYP)
 - ② RAIN WATER RELIEF SCUPPER (TYP)
 - ③ RAIN WATER RELIEF SCUPPER (TYP)
 - ④ CANOPY RAIN WATER RELIEF SCUPPER (TYP)
 - ⑤ ROOF DRAIN (TYP) SEE MECHANICAL DWGS.
 - ⑥ CANOPY ROOF DRAIN (TYP) SEE MECHANICAL DWGS.
 - ⑦ ROOF HATCH
 - ⑧ ROOF TOP UNIT (RTU) AND CURB (TYP) SEE MECHANICAL DWGS.
- NOTES**
1. RAIN WATER RELIEF SCUPPERS TO BE PLACED 50M APART MAX.
 2. ROOF DRAINS TO BE LOCATED 30M FROM EDGE OF ROOF AND 50M APART MAX. ON ROOF AREA. FOR ROOF DRAIN TYPES SEE MECHANICAL DWGS.

No.	ISSUED	DATE
1	ISSUED FOR COORDINATION	MAR. 30, 2021
2	ISSUED FOR SPA	APR. 9, 2021
3	RE-ISSUED FOR SPA	DEC. 10, 2021

No.	REVISION	DATE

BALDASSARRA
Architects Inc.

30 Great Gulf Drive, Unit 20 | Concord ON | L4K 0K7
T. 905.660.0722 | www.baldassarra.ca

OWNERS INFORMATION



FENGATE

772 Winston Churchill Blvd.

Oakville, Ontario

ROOF PLAN
Building B

DATE: MAR. 2021 | DRAWN BY: HP | CHECKED: | SCALE: NTS

PROJECT No. 22-77 B | DRAWING No. **A-2.1**

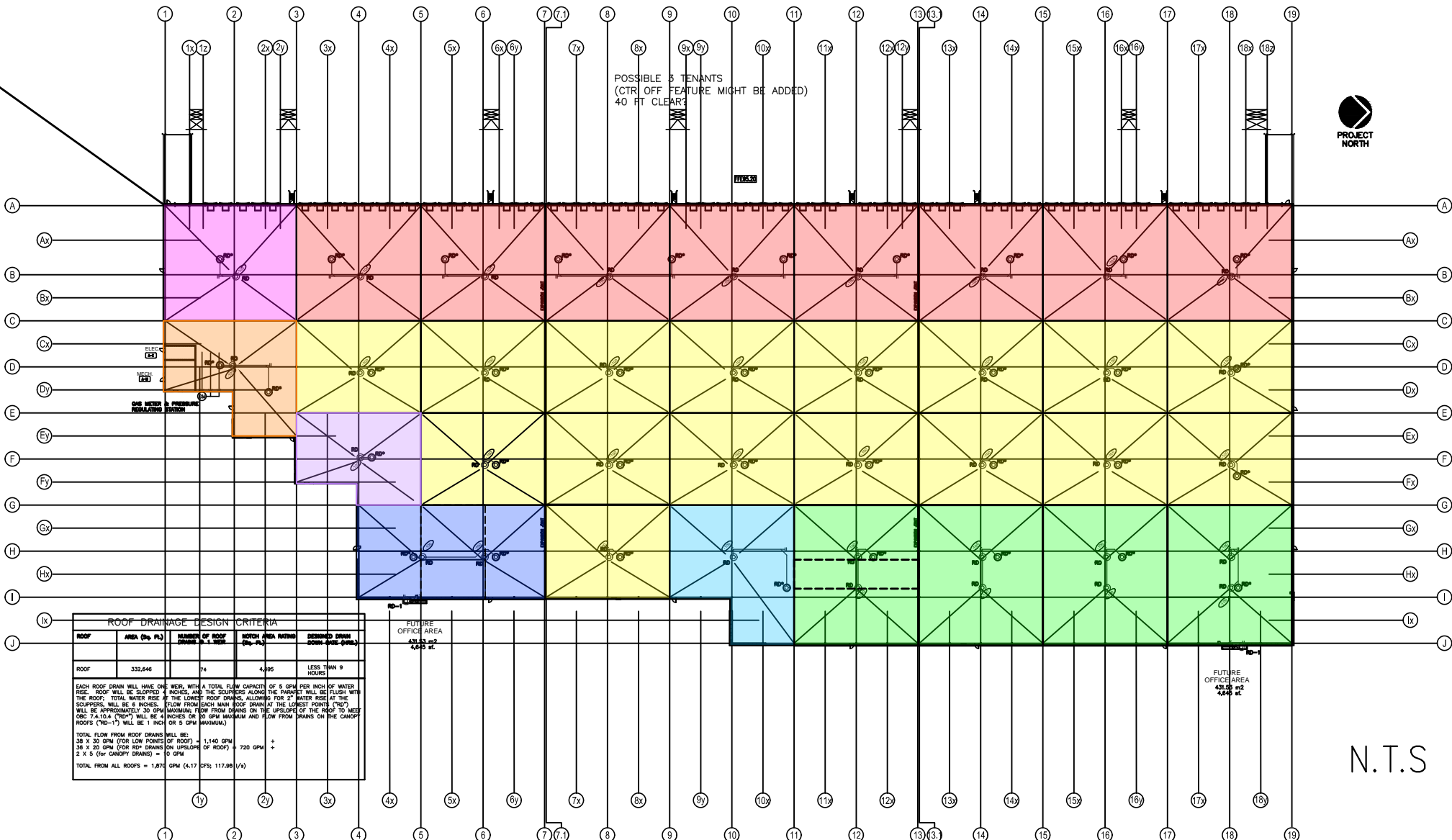

ROOF DRAINAGE DESIGN CRITERIA			
ROOF	AREA (sq. Ft.)	NUMBER OF ROOF DRAINS @ 1 WEIR	DESIGNED DRAIN DOWN (GPM) (GPM)
ROOF	332,646	74	LESS THAN 9 HOURS

EACH ROOF DRAIN WILL HAVE ONE WEIR, WITH A TOTAL FLOW CAPACITY OF 5 GPM PER INCH OF WATER RISE. ROOF WILL BE SLOPPED 1/8 INCHES, AND THE SCUPPERS ALONG THE PARAPET WILL BE FLUSH WITH THE ROOF. TOTAL WATER RISE AT THE LOWEST ROOF DRAINS, ALLOWING FOR 2" WATER RISE AT THE SCUPPERS, WILL BE 6 INCHES. FLOW FROM EACH MAIN ROOF DRAIN AT THE LOWEST POINTS ("RD") WILL BE APPROXIMATELY 30 GPM MAXIMUM, FLOW FROM DRAINS ON THE UPSLOPE OF THE ROOF TO MEET CBC 7.4.10.4 ("RD") WILL BE 4 INCHES OR 10 GPM MAXIMUM AND FLOW FROM DRAINS ON THE CANOPY ROOFS ("RD-1") WILL BE 1 INCH OR 5 GPM MAXIMUM.

TOTAL FLOW FROM ROOF DRAINS WILL BE:
 38 x 30 GPM (FOR LOW POINTS OF ROOF) = 1,140 GPM +
 36 x 20 GPM (FOR RD DRAINS ON UPSLOPE OF ROOF) = 720 GPM +
 2 x 5 (FOR CANOPY DRAINS) = 10 GPM

TOTAL FROM ALL ROOFS = 1,870 GPM (4.17 CFS; 117.98 l/s)

FLOW AT 4" WATER (100mm DEPTH)
 38 x 20 gpm (low points) = 760 gpm
 36 x 10 GPM (for RD*) = 360 GPM
 2 x 5 GPM (Canopy Drains)=10GPM
TOTAL FLOW = 1130 GPM (70.6 l/s)

FLOW AT 5" WATER (125mm DEPTH)
 38 x 25 gpm (low points) = 950 gpm
 36 x 15 GPM (for RD*) = 540 GPM
 2 x 5 GPM (Canopy Drains)=10GPM
TOTAL FLOW = 1500 GPM (94.6 l/s)

N.T.S

BUILDING A ROOF VOLUME SKETCH

BUILDING A: ROOF VOLUME CALCULATIONS

GRID	# BLKS	AREA (m2)	VOLUME AT 100mm DEPTH				VOLUME AT 125mm DEPTH		VOLUME AT 150mm DEPTH			
			DEPTH (m)	VOLUME /BLK (m3)	TOTAL VOLUME m3	TOTAL AREA m2	DEPTH (m)	VOLUME (m3)	DEPTH (m)	VOLUME (m3)		
A-C (3-19)	8	1020	0.10	34.0	272.0	8160	0.025	204.0	0.05	408.0		
A-C (1-3)	1	1090	0.10	36.3	36.3	1090	0.025	27.3	0.05	54.5		
C-E (3-19)	8	805	0.10	26.8	214.7	6440	0.025	161.0	0.05	322.0		
E-G (5-19)	7	805	0.10	26.8	187.8	5635	0.025	140.9	0.05	281.8		
C-Ey (1-3)	1	860	0.10	28.7	28.7	860	0.025	21.5	0.05	43.0		
E-G (3-5)	1	715	0.10	23.8	23.8	715	0.025	17.9	0.05	35.8		
G-I (7-9)	1	826	0.10	27.5	27.5	826	0.025	20.7	0.05	41.3		
G-J (9-12)	1	1030	0.10	34.3	34.3	1030	0.025	25.8	0.05	51.5		
VALLEY1	4	1220	0.10	44.92	179.7	4880	0.025	122.0	0.05	244.0		
VALLEY2	1	1250	0.10	48.75	48.8	1250	0.025	31.3	0.05	62.5		
TOTAL VOLUME AT 100mm DEPTH =							1053.6	30886.0	Incremental Volume =	772.2	Incremental Volume =	1544.3
									TOTAL VOLUME AT 125mm DEPTH =	1825.8		

VOLUME OF CONE = AREA x DEPTH / 3

TOTAL VOLUME AT 150mm DEPTH = 2597.9

VALLEY1 CALCS				GRIDS G-J (11-19)				VALLEY2 CALCS				GRID G-I (4-7)			
TOTAL AREA		1220 m2		TOTAL AREA		1250 m2		TOTAL AREA		1250 m2		TOTAL AREA		1250 m2	
VALLEY AREA		255 m2		VALLEY AREA		425 m2		VALLEY AREA		425 m2		VALLEY AREA		425 m2	
REMAINING "CONE"				VALLEY VOL				REMAINING "CONE"				VALLEY VOL			
CONE AREA		965 m2		VALL AREA		255 m2		CONE AREA		825 m2		VALL AREA		425 m2	
DEPTH		0.1 m		DEPTH		0.1 m		DEPTH		0.1 m		DEPTH		0.1 m	
VOL		32.17 m3		VOL		12.75 m3		VOL		27.5 m3		VOL		21.25 m3	
TOTAL VALLEY VOL =				44.917 m3/VALLEY				TOTAL VALLEY VOL =				48.75 m3/VALLEY			
# VALLEYS				4				# VALLEYS				1			
				179.67 m3								48.75 m3			

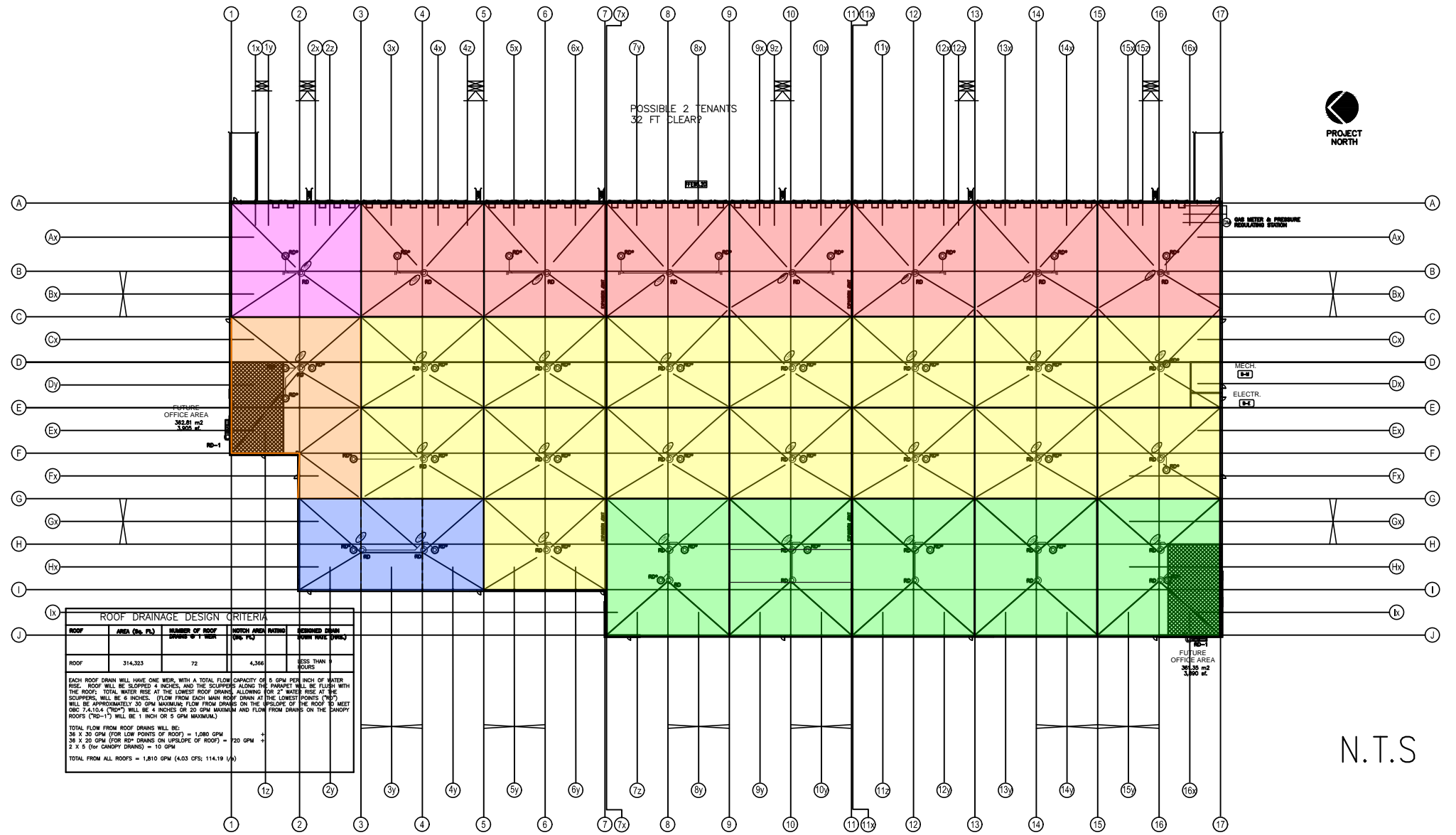

ROOF DRAINAGE DESIGN CRITERIA

ROOF	AREA (sq. ft.)	NUMBER OF ROOF DRAINS @ 1' SPAC	NOTCH AREA (sq. ft.)	DESIGNED DRAIN DOWN WALK (DRAIN)
ROOF	314,323	72	4,366	LESS THAN 1 INCH

EACH ROOF DRAIN WILL HAVE ONE WEIR, WITH A TOTAL FLOW CAPACITY OF 5 GPM PER INCH OF WATER RISE. ROOF WILL BE SLOPPED 4 INCHES, AND THE SCUPPERS ALONG THE PARAPET WILL BE FLOWING WITH THE ROOF. TOTAL WATER RISE AT THE LOWEST ROOF DRAINS ALLOWING FOR 2" WATER RISE AT THE SCUPPERS, WILL BE 6 INCHES. FLOW FROM EACH MAIN ROOF DRAIN AT THE LOWEST POINTS (RD*) WILL BE APPROXIMATELY 30 GPM MAXIMUM FLOW FROM DRAINS ON THE UPSLOPE OF THE ROOF TO MEET ORC (7.4.10.4 (RD*)) WILL BE 4 INCHES OR 20 GPM MAXIMUM AND FLOW FROM DRAINS ON THE DOWNSLOPE (RD-1) WILL BE 1 INCH OR 5 GPM MAXIMUM.

TOTAL FLOW FROM ROOF DRAINS WILL BE:
 36 x 30 GPM (FOR LOW POINTS OF ROOF) = 1,080 GPM +
 36 x 20 GPM (FOR RD* DRAINS ON UPSLOPE OF ROOF) = 720 GPM +
 2 x 5 GPM (FOR CANOPY DRAINS) = 10 GPM
 TOTAL FROM ALL ROOFS = 1,810 GPM (4.03 GFS; 114.19 l/s)

FLOW AT 4" WATER
 36 x 20 gpm (low points) = 720 gpm
 36 x 10 GPM (for RD*) = 360 GPM
 2 x 5 GPM (Canopy Drains)=10GPM
TOTAL FLOW = 1090 GPM (68.8 l/s)

FLOW AT 5" WATER (125mm DEPTH)
 36 x 25 gpm (low points) = 900 GPM
 36 x 15 GPM (for RD*) = 540 GPM
 2 x 5 GPM (Canopy Drains)=10 GPM
TOTAL FLOW = 1450 GPM (91.5 l/s)

N.T.S

**BUILDING B
 ROOF VOLUME SKETCH**

BUILDING B: ROOF VOLUME CALCULATIONS

GRID	# BLKS	AREA (m2)	VOLUME AT 100mm DEPTH				VOLUME AT 125mm DEPTH		VOLUME AT 150mm DEPTH	
			DEPTH (m)	VOLUME /BLK (m3)	TOTAL VOLUME m3	TOTAL AREA m2	DEPTH (m)	VOLUME (m3)	DEPTH (m)	VOLUME (m3)
A-C (3-17)	7	1015	0.10	33.8	236.8	7105	0.025	177.6	0.05	355.3
A-C (1-3)	1	1060	0.10	35.3	35.3	1060	0.025	26.5	0.05	53.0
C-E (3-17)	7	815	0.10	27.2	190.2	5705	0.025	142.6	0.05	285.3
E-G (3-17)	7	815	0.10	27.2	190.2	5705	0.025	142.6	0.05	285.3
C-F (1-3)	1	1470	0.10	49.0	49.0	1470	0.025	36.8	0.05	73.5
G-I (3-5)	1	815	0.10	27.2	27.2	815	0.025	20.4	0.05	40.8
VALLEY1	5	1220	0.10	45.50	227.5	6100	0.025	152.5	0.05	305.0
VALLEY2	1	1240.0	0.10	48.14	48.1	1240	0.025	31.0	0.05	62.0
							Incremental		Incremental	
TOTAL VOLUME AT 100mm DEPTH =					1004.3	29200.0	Volume =	730.0	Volume =	1460.0

TOTAL VOLUME AT 125mm DEPTH = 1734.3

TOTAL VOLUME AT 150mm DEPTH = 2464.3

VOLUME OF CONE = AREA x DEPTH / 3

VALLEY1 CALCS				GRIDS G-J (7-17)				VALLEY2 CALCS				GRID G-I (1-5)			
TOTAL AREA		1220 m2		TOTAL AREA		1240 m2		TOTAL AREA		831.5 m2		TOTAL AREA		408.5 m2	
VALLEY AREA		290		VALLEY AREA		290 m2		VALLEY AREA		408.5 m2		VALLEY AREA		408.5 m2	
REMAINING "CONE"				VALLEY VOL				REMAINING "CONE"				VALLEY VOL			
CONE AREA		930 m2		VALL AREA		290 m2		CONE AREA		831.5 m2		VALL AREA		408.5 m2	
DEPTH		0.1 m		DEPTH		0.1 m		DEPTH		0.1 m		DEPTH		0.1 m	
VOL		31 m3		VOL		14.5 m3		VOL		27.7 m3		VOL		20.425 m3	
TOTAL VALLEY VOL =				45.500				TOTAL VALLEY VOL =				48.14			
# VALLEYS				5				# VALLEYS				1			
				227.50 m3								48.14 m3			

STORM SEWER DESIGN SHEET



a.m. candaras associates inc.
consulting engineers

Project / Subdivision 772 WINSTON CHURCHILL BLVD., OAKVILLE

Consulting Engineer A.M. Candaras Associates Inc.

Project No.: #2256

Prepared by: F.P.

Checked by: A.M.C.

Last Revised: 14-Dec-22

Design Parameters				Design Equations	
A = drainage area (ha)	$5_{YR} T_{init} = 10$	$100_{YR} T_{init} = 10$		$I = \frac{A}{(t + B)^C}$	
C = runoff coefficient	A = 1170	A = 2150			
T_c = time of concentration	B = 5.800	B = 5.700		$Q = 2.78 \times A \times C \times I$	
	C = 0.843	C = 0.861			

Notes/Comments: 5 year sewers																		
Location			Drainage Area Characteristics				Rainfall / Runoff			Sewer Data							Remarks	
Street	From	To	Area (ha)	C	AC	Accum. AC	T_c (min)	I (mm/hr)	Flow (m ³ /s)	Diameter (mm)	Length (m)	Slope (%)	Cap. (m ³ /s)	Vel. (m/s)	Sect. Time	Accum. Time		
	MH.	MH.																
STM PIPE NETWORK TO HW 1																		
																	10.00	minimum entry time
Building A - East Side	CB 20	CBMH 28	0.1200	0.90	0.11	0.11	10.00	114.21	0.034	300	34.5	1.00	0.097	1.37	0.42	10.42		
Building A - East Side	CB 19	CBMH 28	0.0675	0.90	0.06	0.06	10.00	114.21	0.019	300	1.1	1.00	0.097	1.37	0.01	10.01		
Building A - East Side	CBMH 28	CBMH 27	0.1065	0.90	0.10	0.26	10.42	111.71	0.082	450	71.9	0.50	0.202	1.27	0.95	11.37		
Building A - East Side	CBMH 27	CBMH 26	0.1280	0.90	0.12	0.38	11.37	106.50	0.112	450	57.0	0.50	0.202	1.27	0.75	12.12		
Building A - East Side	CBMH 26	MH 86	0.1156	0.85	0.10	0.48	12.12	102.74	0.136	525	35.2	0.50	0.304	1.40	0.42	12.53		
Building A - East Side	MH 86	DCBMH 25	0.0000	0.85	0.00	0.48	12.53	100.76	0.134	525	24.9	0.50	0.304	1.40	0.30	12.83		
Building A - East Side	DCBMH 25	HW 2	0.1200	0.90	0.11	0.59	12.83	99.41	0.162	525	17.4	1.00	0.430	1.99	0.15	12.68		
Building A - South Side	HW 2	DDICB 18	0.0000	0.90	0.00	0.59	12.68	100.09	0.163	525	1.0	0.30	0.236	1.09	0.02	12.69		* FLOW THROUGH DRY POND *
Building A - South Side	DDICB 18	MH 29	0.2370	0.90	0.21	0.80	12.69	100.02	0.222	525	21.0	0.30	0.236	1.09	0.32	13.02		
Building A - South Side	DCB 7	MH 29	0.1050	0.90	0.09	0.09	10.00	114.21	0.030	300	20.4	1.00	0.097	1.37	0.25	10.25		
Building A - South Side	MH 29	MH 4	0.0000	0.90	0.00	0.89	13.02	98.57	0.245	600	15.6	0.25	0.307	1.09	0.24	13.26		
Building A - North Side	CB 11	CBMH 14	0.1080	0.90	0.10	0.10	10.00	114.21	0.031	300	40.1	0.50	0.068	0.97	0.69	10.69		
Building A - North Side	CBMH 14	CBMH 13	0.0720	0.90	0.06	0.16	10.69	110.17	0.050	375	49.6	0.50	0.124	1.12	0.74	11.43		
Building A - North Side	CBMH 13	CBMH 12	0.0820	0.80	0.07	0.23	10.00	114.21	0.072	375	73.5	0.50	0.124	1.12	1.09	11.09		
Building A - North Side	CBMH 12	DCBMH 11	0.0730	0.90	0.07	0.29	11.43	106.18	0.087	375	50.3	0.50	0.124	1.12	0.75	12.17		
Building B North Side	CB 17	CBMH 24	0.1015	0.90	0.09	0.09	10.00	114.21	0.029	300	62.6	1.00	0.097	1.37	0.76	10.76		minimum entry time
Building B North Side	CB 16	CBMH 24	0.0940	0.90	0.08	0.08	10.00	114.21	0.027	300	8.0	2.00	0.137	1.93	0.07	10.83		
Building B North Side	CBMH 24	DCBMH 11	0.0645	0.90	0.06	0.23	12.17	102.45	0.067	375	66.0	1.50	0.215	1.94	0.57	11.33		
North Loading Dock	DCB 10	DCBMH 11	0.0715	0.90	0.06	0.06	10.00	114.21	0.020	300	43.4	1.90	0.133	1.89	0.38	10.38		
Loading Dock	DCB 6	DCBMH 11	0.3820	0.90	0.34	0.34	10.00	114.21	0.109	375	39.7	0.75	0.152	1.37	0.48	10.86		

STORM SEWER DESIGN SHEET



a.m. candaras associates inc.
consulting engineers

Project / Subdivision 772 WINSTON CHURCHILL BLVD., OAKVILLE

Consulting Engineer A.M. Candaras Associates Inc.

Project No.: #2256

Prepared by: F.P.

Checked by: A.M.C.

Last Revised: 14-Dec-22

Design Parameters				Design Equations	
A = drainage area (ha)	$5_{YR} T_{init} = 10$	$100_{YR} T_{init} = 10$		$I = \frac{A}{(t + B)^C}$	
C = runoff coefficient	A = 1170	A = 2150			
T_c = time of concentration	B = 5.800	B = 5.700		$Q = 2.78 \times A \times C \times I$	
	C = 0.843	C = 0.861			

Notes/Comments: 5 year sewers																	
Location			Drainage Area Characteristics				Rainfall / Runoff			Sewer Data							Remarks
Street	From	To	Area (ha)	C	AC	Accum. AC	T_c (min)	I (mm/hr)	Flow (m ³ /s)	Diameter (mm)	Length (m)	Slope (%)	Cap. (m ³ /s)	Vel. (m/s)	Sect. Time	Accum. Time	
	MH.	MH.															
Loading Dock	DCB 9	DCBMH 11	0.2010	0.90	0.18	0.18	10.00	114.21	0.057	300	1.2	0.50	0.068	0.97	0.02	10.89	
Loading Dock	DCB 5	DCBMH 11	0.2825	0.90	0.25	0.25	10.00	114.21	0.081	375	39.7	0.50	0.124	1.12	0.59	11.35	
Loading Dock	DCBMH 11	DCBMH 10	0.2860	0.90	0.26	1.63	10.89	109.08	0.493	675	100.0	0.45	0.564	1.58	1.06	11.94	
Loading Dock	DCB 4	DCBMH 10	0.2835	0.90	0.26	0.26	10.00	114.21	0.081	375	38.9	1.00	0.175	1.59	0.41	10.41	
Loading Dock	DCB 8	DCBMH 10	0.2010	0.90	0.18	0.18	10.00	114.21	0.057	300	4.9	1.00	0.097	1.37	0.06	10.06	
Loading Dock	DCBMH 10	MH 9	0.2010	0.90	0.18	2.24	10.41	111.78	0.697	750	99.8	0.45	0.747	1.69	0.98	11.39	minimum entry time
South Loading Dock	DCB 3	MH 15	0.2830	0.90	0.25	0.25	10.00	114.21	0.081	300	37.2	1.00	0.097	1.37	0.45	12.63	
South Loading Dock	DCB 2	DCBMH 16	0.3420	0.90	0.31	0.31	10.00	114.21	0.098	375	49.3	0.85	0.162	1.46	0.56	10.56	
South Loading Dock	DCBMH 16	MH 15	0.2825	0.90	0.25	0.56	10.56	110.90	0.173	450	38.1	1.00	0.285	1.79	0.35	10.92	
Building A Roof	BLDG A	MH 15 *	3.091	0.90	2.78	2.78	10.92	108.92	0.118	375	28.5	0.45	0.118	1.06	0.45	11.36	* Controlled roof flow = 118.0 l/s
South Loading Dock	MH 15	MH 9	0.0000	0.90	0.00	0.82	11.36	106.53	0.360	600	30.5	0.50	0.434	1.54	0.33	11.69	
																10.00	minimum entry time
West Site Area	DCB 15	CBMH 23	0.1880	0.90	0.17	0.17	10.00	114.21	0.054	300	55.6	0.50	0.068	0.97	0.96	10.96	
West Site Area	CB 14	CBMH 23	0.0865	0.90	0.08	0.08	10.00	114.21	0.025	300	0.9	1.00	0.097	1.37	0.01	10.97	
West Site Area	CBMH 23	CBMH 22	0.0830	0.90	0.07	0.32	10.96	108.68	0.097	375	84.3	0.50	0.124	1.12	1.25	12.21	
West Site Area	CBMH 22	CBMH 21	0.1045	0.90	0.09	0.42	12.21	102.28	0.118	450	34.6	0.50	0.202	1.27	0.45	12.66	
South Bldg B Site Area	CB 13	CBMH 21	0.0720	0.90	0.06	0.06	12.66	100.15	0.018	300	2.5	1.00	0.097	1.37	0.03	12.69	
South Bldg B Site Area	CBMH 21	MH 20	0.0540	0.90	0.05	0.53	12.69	100.01	0.147	450	88.5	0.45	0.191	1.20	1.23	13.92	
South Bldg B Site Area	CB 12	MH 20	0.0740	0.90	0.07	0.07	10.00	114.21	0.021	300	2.4	2.00	0.137	1.93	0.02	10.02	
South Bldg B Site Area	MH 20	MH 19	0.0000	0.90	0.00	0.60	13.92	94.74	0.157	450	63.7	0.50	0.202	1.27	0.84	14.76	
South Loading Dock	MH 19	DCBMH 18	0.0000	0.90	0.00	0.60	14.76	91.48	0.151	450	42.2	0.45	0.191	1.20	0.58	15.34	
South Loading Dock	DCBMH 18	DCBMH 17	0.2805	0.90	0.25	0.85	15.34	89.34	0.211	600	73.0	0.45	0.412	1.46	0.84	16.18	
Building B Roof	BLDG B	DCBMH 17 *	2.8970	0.90	2.61	2.61	10.00	114.21	0.1142	375	26.8	0.45	0.118	1.06	0.42	10.42	* Controlled roof flow = 114.28 l/s
Site	DCBMH 17	MH 9	0.2415	0.90	0.22	1.07	16.18	86.47	0.370	600	7.6	0.65	0.495	1.75	0.07	16.25	
Site	MH 9	MH 8	0.00	0.90	0.00	4.13	16.25	86.23	1.221	975	28.1	0.45	1.503	2.01	0.23	16.48	

STORM SEWER DESIGN SHEET



a.m. candaras associates inc.
consulting engineers

Project / Subdivision 772 WINSTON CHURCHILL BLVD., OAKVILLE

Consulting Engineer A.M. Candaras Associates Inc.

Project No.: #2256

Prepared by: F.P.

Checked by: A.M.C.

Last Revised: 14-Dec-22

Design Parameters				Design Equations	
A = drainage area (ha)	$5_{yr} T_{init} = 10$	$100_{yr} T_{init} = 10$		$I = \frac{A}{(t + B)^C}$	
C = runoff coefficient	A= 1170	A= 2150			
T_c = time of concentration	B= 5.800	B= 5.700		$Q = 2.78 \times A \times C \times I$	
	C= 0.843	C= 0.861			

Notes/Comments: 5 year sewers																	
Location			Drainage Area Characteristics				Rainfall / Runoff			Sewer Data							Remarks
Street	From	To	Area	C	AC	Accum.	T_c	I	Flow	Diameter	Length	Slope	Cap.	Vel.	Sect.	Accum.	
	MH.	MH.	(ha)			AC	(min)	(mm/hr)	(m ³ /s)	(mm)	(m)	(%)	(m ³ /s)	(m/s)	Time	Time	
** STORMTECH CHAMBERS **																	
Site	MH 8	MH 7	0.00	0.90	0.00	4.13	16.48	85.47	1.212	975	1.0	0.50	1.585	2.12	0.01	16.49	
Site	MH 7	MH 6	0.00	0.90	0.00	4.13	16.49	85.45	1.212	975	16.7	0.50	1.585	2.12	0.13	16.62	
Site	CB 1	MH 6	0.0750	0.90	0.07	0.07	11.69	104.82	0.020	300	2.0	1.00	0.097	1.37	0.02	11.72	
Site	MH 6	DCBMH 5	0.00	0.90	0.00	4.19	16.62	85.03	1.223	975	88.4	0.35	1.326	1.78	0.83	17.45	

SIZE OF RIPRAP

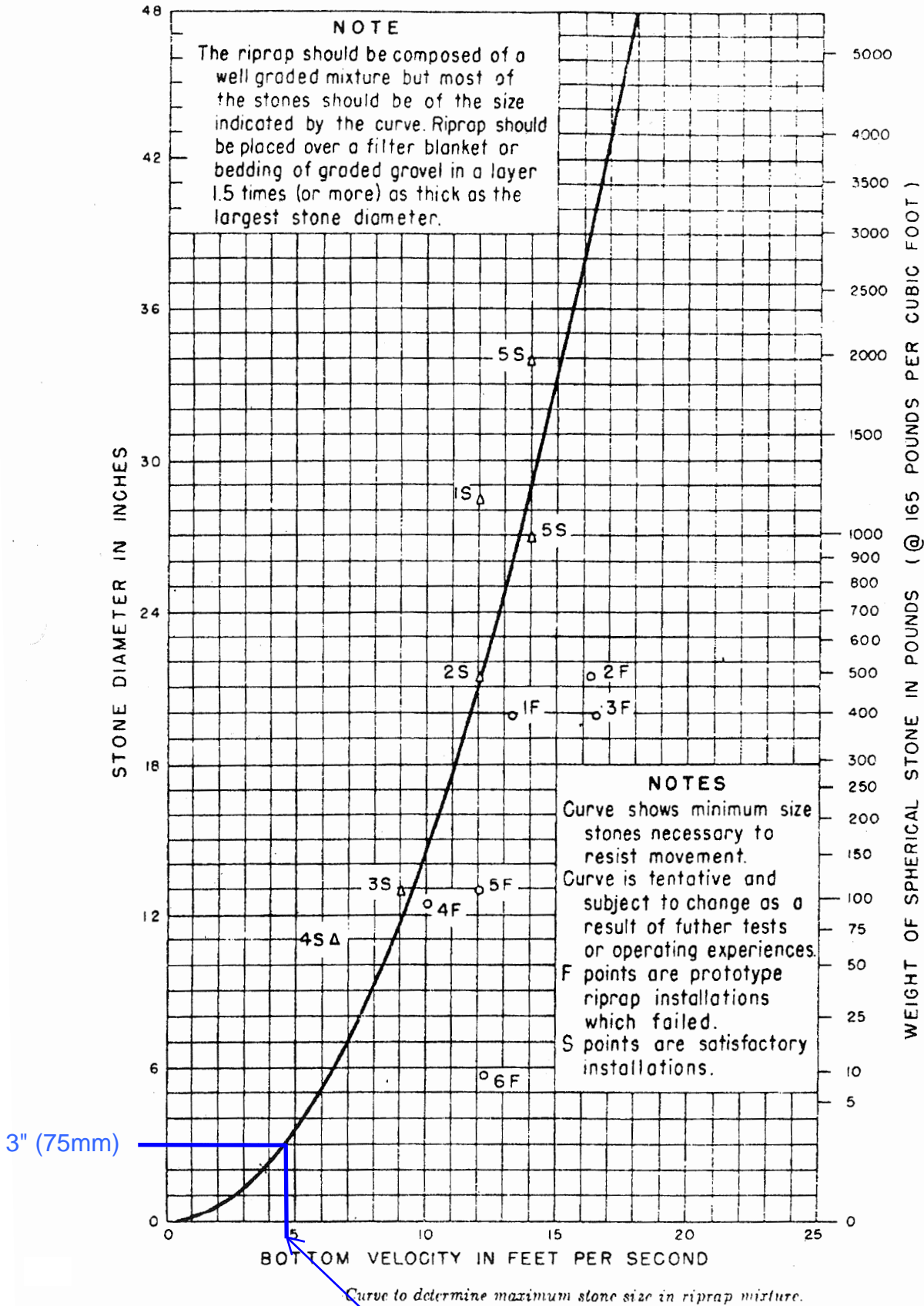

4.6 ft/s (1.42 m/s)
 525mm DIA. @ 0.50%
 HEADWALL#1
 $Q_{FULL} = 0.317m^3/s$

FIGURE 1.67

Project: _____

Chamber Model -
Units -
Number of Chambers -
Number of End Caps -
Voids in the stone (porosity) -
Base of Stone Elevation -
Amount of Stone Above Chambers -
Amount of Stone Below Chambers -

MC-4500
Metric
372
20
40
90.00
305
229

 Include Perimeter Stone in Calculations

1399 sq.meters Min. Area - 1326.916 sq.meters

Height of System (mm)	Incremental Single Chamber (cubic meters)	Incremental Single End Cap (cubic meters)	Incremental Chambers (cubic meters)	Incremental End Cap (cubic meters)	Incremental Stone (cubic meters)	Incremental Chamber, End Cap and Stone (cubic meters)	Cumulative System (cubic meters)	Elevation (meters)
2057	0.00	0.00	0.00	0.00	14.207	14.21	1837.34	92.06
2032	0.00	0.00	0.00	0.00	14.207	14.21	1823.13	92.03
2007	0.00	0.00	0.00	0.00	14.207	14.21	1808.93	92.01
1981	0.00	0.00	0.00	0.00	14.207	14.21	1794.72	91.98
1956	0.00	0.00	0.00	0.00	14.207	14.21	1780.51	91.96
1930	0.00	0.00	0.00	0.00	14.207	14.21	1766.31	91.93
1905	0.00	0.00	0.00	0.00	14.207	14.21	1752.10	91.91
1880	0.00	0.00	0.00	0.00	14.207	14.21	1737.89	91.88
1854	0.00	0.00	0.00	0.00	14.207	14.21	1723.69	91.85
1829	0.00	0.00	0.00	0.00	14.207	14.21	1709.48	91.83
1803	0.00	0.00	0.00	0.00	14.207	14.21	1695.27	91.80
1778	0.00	0.00	0.00	0.00	14.207	14.21	1681.07	91.78
1753	0.00	0.00	0.43	0.01	14.031	14.47	1666.86	91.75
1727	0.00	0.00	1.22	0.02	13.710	14.95	1652.39	91.73
1702	0.00	0.00	1.74	0.03	13.501	15.27	1637.44	91.70
1676	0.01	0.00	2.20	0.04	13.312	15.55	1622.17	91.68
1651	0.01	0.00	2.83	0.05	13.057	15.93	1606.63	91.65
1626	0.01	0.00	4.77	0.06	12.275	17.10	1590.69	91.63
1600	0.02	0.00	7.01	0.07	11.374	18.46	1573.59	91.60
1575	0.02	0.00	8.42	0.09	10.804	19.31	1555.13	91.57
1549	0.03	0.01	9.57	0.11	10.337	20.01	1535.82	91.55
1524	0.03	0.01	10.56	0.12	9.931	20.62	1515.81	91.52
1499	0.03	0.01	11.45	0.14	9.569	21.16	1495.19	91.50
1473	0.03	0.01	12.26	0.16	9.242	21.65	1474.03	91.47
1448	0.03	0.01	13.00	0.17	8.939	22.11	1452.38	91.45
1422	0.04	0.01	13.69	0.19	8.656	22.53	1430.27	91.42
1397	0.04	0.01	14.34	0.20	8.392	22.93	1407.73	91.40
1372	0.04	0.01	14.94	0.22	8.142	23.30	1384.80	91.37
1346	0.04	0.01	15.52	0.23	7.906	23.66	1361.50	91.35
1321	0.04	0.01	16.07	0.25	7.680	24.00	1337.84	91.32
1295	0.04	0.01	16.59	0.27	7.466	24.32	1313.85	91.30
1270	0.05	0.01	17.08	0.28	7.263	24.62	1289.53	91.27
1245	0.05	0.01	17.55	0.29	7.068	24.91	1264.91	91.24
1219	0.05	0.02	18.00	0.31	6.882	25.19	1239.99	91.22
1194	0.05	0.02	18.44	0.32	6.704	25.46	1214.80	91.19
1168	0.05	0.02	18.85	0.33	6.534	25.72	1189.34	91.17
1143	0.05	0.02	19.25	0.35	6.369	25.96	1163.62	91.14
1118	0.05	0.02	19.63	0.36	6.212	26.20	1137.66	91.12
1092	0.05	0.02	20.00	0.36	6.062	26.42	1111.46	91.09
1067	0.05	0.02	20.35	0.38	5.913	26.65	1085.04	91.07
1041	0.06	0.02	20.69	0.40	5.772	26.86	1058.39	91.04
1016	0.06	0.02	21.02	0.41	5.636	27.06	1031.53	91.02
991	0.06	0.02	21.33	0.42	5.506	27.26	1004.47	90.99
965	0.06	0.02	21.63	0.43	5.380	27.45	977.21	90.97
940	0.06	0.02	21.93	0.44	5.258	27.63	949.76	90.94
914	0.06	0.02	22.21	0.45	5.142	27.80	922.13	90.91
889	0.06	0.02	22.48	0.46	5.030	27.97	894.33	90.89
864	0.06	0.02	22.74	0.47	4.921	28.14	866.36	90.86
838	0.06	0.02	22.99	0.48	4.818	28.29	838.22	90.84
813	0.06	0.02	23.23	0.49	4.719	28.44	809.93	90.81
787	0.06	0.03	23.47	0.50	4.619	28.59	781.50	90.79
762	0.06	0.03	23.69	0.51	4.526	28.73	752.91	90.76
737	0.06	0.03	23.91	0.52	4.437	28.86	724.18	90.74
711	0.06	0.03	24.11	0.52	4.353	28.99	695.32	90.71
686	0.07	0.03	24.31	0.53	4.269	29.11	666.33	90.69
660	0.07	0.03	24.50	0.54	4.189	29.23	637.22	90.66
635	0.07	0.03	24.68	0.55	4.114	29.35	607.98	90.64
610	0.07	0.03	24.86	0.56	4.041	29.46	578.64	90.61
584	0.07	0.03	25.03	0.55	3.976	29.55	549.18	90.58
559	0.07	0.03	25.19	0.57	3.905	29.66	519.63	90.56
533	0.07	0.03	25.34	0.57	3.842	29.75	489.97	90.53
508	0.07	0.03	25.48	0.58	3.782	29.84	460.22	90.51
483	0.07	0.03	25.62	0.58	3.724	29.93	430.37	90.48
457	0.07	0.03	25.75	0.59	3.670	30.01	400.44	90.46
432	0.07	0.03	25.88	0.59	3.618	30.09	370.43	90.43
406	0.07	0.03	26.00	0.60	3.570	30.16	340.34	90.41
381	0.07	0.03	26.11	0.59	3.526	30.23	310.18	90.38
356	0.07	0.03	26.21	0.60	3.483	30.29	279.95	90.36
330	0.07	0.03	26.31	0.61	3.439	30.36	249.66	90.33
305	0.07	0.03	26.40	0.61	3.400	30.42	219.30	90.30
279	0.07	0.03	26.49	0.62	3.364	30.47	188.88	90.28
254	0.07	0.03	26.62	0.63	3.309	30.55	158.41	90.25
229	0.00	0.00	0.00	0.00	14.207	14.21	127.86	90.23
203	0.00	0.00	0.00	0.00	14.207	14.21	113.65	90.20
178	0.00	0.00	0.00	0.00	14.207	14.21	99.45	90.18
152	0.00	0.00	0.00	0.00	14.207	14.21	85.24	90.15
127	0.00	0.00	0.00	0.00	14.207	14.21	71.03	90.13
102	0.00	0.00	0.00	0.00	14.207	14.21	56.83	90.10
76	0.00	0.00	0.00	0.00	14.207	14.21	42.62	90.08
51	0.00	0.00	0.00	0.00	14.207	14.21	28.41	90.05
25	0.00	0.00	0.00	0.00	14.207	14.21	14.21	90.03

MC-4500 TECHNICAL SPECIFICATION

NTS

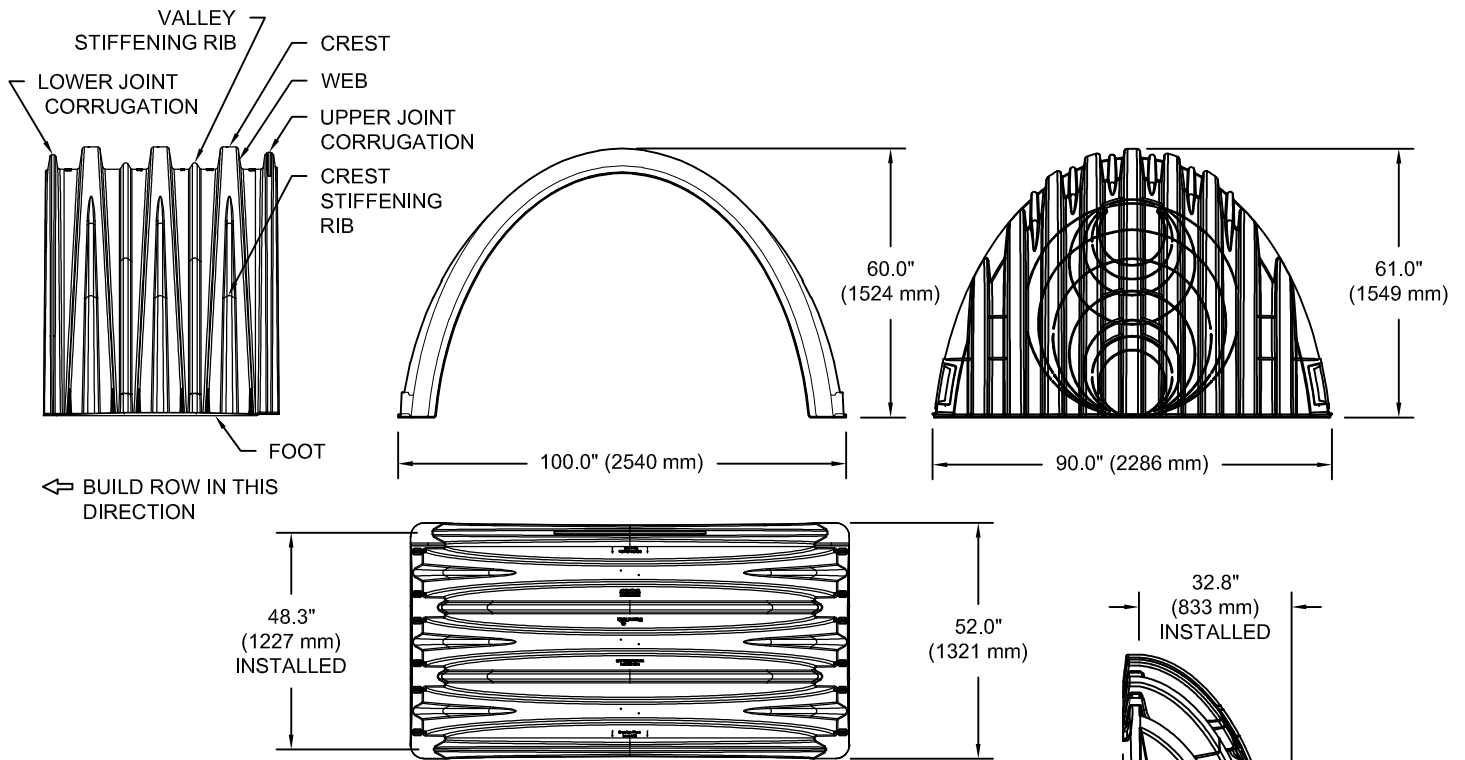

NOMINAL CHAMBER SPECIFICATIONS

SIZE (W X H X INSTALLED LENGTH)	100.0" X 60.0" X 48.3"	(2540 mm X 1524 mm X 1227 mm)
CHAMBER STORAGE	106.5 CUBIC FEET	(3.01 m ³)
MINIMUM INSTALLED STORAGE*	162.6 CUBIC FEET	(4.60 m ³)
WEIGHT (NOMINAL)	125.0 lbs.	(56.7 kg)

NOMINAL END CAP SPECIFICATIONS

SIZE (W X H X INSTALLED LENGTH)	90.0" X 61.0" X 32.8"	(2286 mm X 1549 mm X 833 mm)
END CAP STORAGE	39.5 CUBIC FEET	(1.12 m ³)
MINIMUM INSTALLED STORAGE*	115.3 CUBIC FEET	(3.26 m ³)
WEIGHT (NOMINAL)	90 lbs.	(40.8 kg)

*ASSUMES 12" (305 mm) STONE ABOVE, 9" (229 mm) STONE FOUNDATION AND BETWEEN CHAMBERS, 12" (305 mm) STONE PERIMETER IN FRONT OF END CAPS AND 40% STONE POROSITY.

PARTIAL CUT HOLES AT BOTTOM OF END CAP FOR PART NUMBERS ENDING WITH "B"
 PARTIAL CUT HOLES AT TOP OF END CAP FOR PART NUMBERS ENDING WITH "T"
 END CAPS WITH A PREFABRICATED WELDED STUB END WITH "W"

PART #	STUB	B	C
MC4500IEPP06T	6" (150 mm)	42.54" (1081 mm)	---
MC4500IEPP06B		---	0.86" (22 mm)
MC4500IEPP08T	8" (200 mm)	40.50" (1029 mm)	---
MC4500IEPP08B		---	1.01" (26 mm)
MC4500IEPP10T	10" (250 mm)	38.37" (975 mm)	---
MC4500IEPP10B		---	1.33" (34 mm)
MC4500IEPP12T	12" (300 mm)	35.69" (907 mm)	---
MC4500IEPP12B		---	1.55" (39 mm)
MC4500IEPP15T	15" (375 mm)	32.72" (831 mm)	---
MC4500IEPP15B		---	1.70" (43 mm)
MC4500IEPP18T	18" (450 mm)	29.36" (746 mm)	---
MC4500IEPP18TW		---	---
MC4500IEPP18B		---	1.97" (50 mm)
MC4500IEPP18BW		---	---
MC4500IEPP24T	24" (600 mm)	23.05" (585 mm)	---
MC4500IEPP24TW		---	---
MC4500IEPP24B		---	2.26" (57 mm)
MC4500IEPP24BW		---	---
MC4500IEPP30BW	30" (750 mm)	---	2.95" (75 mm)
MC4500IEPP36BW	36" (900 mm)	---	3.25" (83 mm)
MC4500IEPP42BW	42" (1050 mm)	---	3.55" (90 mm)

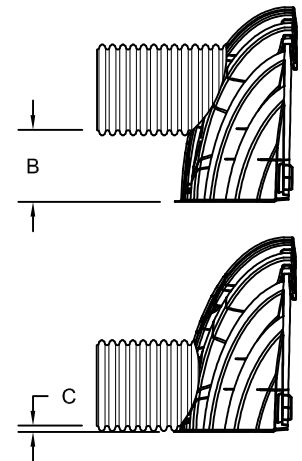

CUSTOM PREFABRICATED INVERTS ARE AVAILABLE UPON REQUEST. INVENTORIED MANIFOLDS INCLUDE 12-24" (300-600 mm) SIZE ON SIZE AND 15-48" (375-1200 mm) ECCENTRIC MANIFOLDS. CUSTOM INVERT LOCATIONS ON THE MC-4500 END CAP CUT IN THE FIELD ARE NOT RECOMMENDED FOR PIPE SIZES GREATER THAN 10" (250 mm). THE INVERT LOCATION IN COLUMN 'B' ARE THE HIGHEST POSSIBLE FOR THE PIPE SIZE.

NOTE: ALL DIMENSIONS ARE NOMINAL

User Inputs

Chamber Model:	MC-4500
Outlet Control Structure:	Yes
Project Name:	772 WCB Dec 2021
Engineer:	Fanche Petkovski
Project Location:	New York
Measurement Type:	Metric
Required Storage Volume:	1800.00 cubic meters.
Stone Porosity:	40%
Stone Foundation Depth:	229 mm.
Stone Above Chambers:	305 mm.
Average Cover Over Chambers:	610 mm.
Design Constraint Dimensions:	(30.00 m. x 52.00 m.)

Results

System Volume and Bed Size

Installed Storage Volume:	1837.71 cubic meters.
Storage Volume Per Chamber:	3.02 cubic meters.
Number Of Chambers Required:	372
Number Of End Caps Required:	20
Chamber Rows:	10
Maximum Length:	50.30 m.
Maximum Width:	28.25 m.
Approx. Bed Size Required:	1398.83 square meters.

System Components

Amount Of Stone Required:	1733.69 cubic meters
Volume Of Excavation (Not Including Fill):	2877.87 cubic meters
Total Non-woven Geotextile Required:	4486.3 square meters
Woven Geotextile Required (excluding Isolator Row):	191.1 square meters
Woven Geotextile Required (Isolator Row):	369.64 square meters
Total Woven Geotextile Required:	560.74 square meters

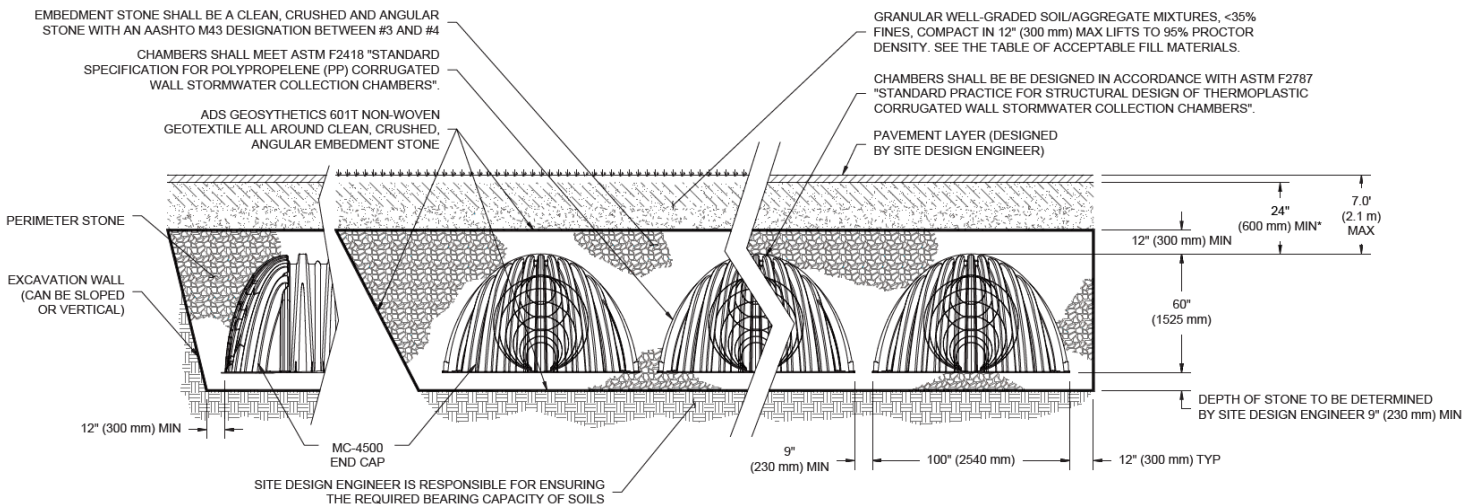

*MINIMUM COVER TO BOTTOM OF FLEXIBLE PAVEMENT. FOR UNPAVED INSTALLATIONS WHERE RUTTING FROM VEHICLES MAY OCCUR, INCREASE COVER TO 30" (750 mm).

ACCEPTABLE FILL MATERIALS: STORMTECH MC-4500 CHAMBER SYSTEMS

MATERIAL LOCATION		DESCRIPTION	AASHTO MATERIAL CLASSIFICATIONS	COMPACTION / DENSITY REQUIREMENT
D	FINAL FILL: FILL MATERIAL FOR LAYER 'D' STARTS FROM THE TOP OF THE 'C' LAYER TO THE BOTTOM OF FLEXIBLE PAVEMENT OR UNPAVED FINISHED GRADE ABOVE. NOTE THAT PAVEMENT SUBBASE MAY BE PART OF THE 'D' LAYER	ANY SOIL/ROCK MATERIALS, NATIVE SOILS, OR PER ENGINEER'S PLANS. CHECK PLANS FOR PAVEMENT SUBGRADE REQUIREMENTS.	N/A	PREPARE PER SITE DESIGN ENGINEER'S PLANS. PAVED INSTALLATIONS MAY HAVE STRINGENT MATERIAL AND PREPARATION REQUIREMENTS.
C	INITIAL FILL: FILL MATERIAL FOR LAYER 'C' STARTS FROM THE TOP OF THE EMBEDMENT STONE ('B' LAYER) TO 24" (600 mm) ABOVE THE TOP OF THE CHAMBER. NOTE THAT PAVEMENT SUBBASE MAY BE A PART OF THE 'C' LAYER.	GRANULAR WELL-GRADED SOIL/AGGREGATE MIXTURES, <35% FINES OR PROCESSED AGGREGATE. MOST PAVEMENT SUBBASE MATERIALS CAN BE USED IN LIEU OF THIS LAYER.	AASHTO M145' A-1, A-2-4, A-3 OR AASHTO M43' 3, 357, 4, 467, 5, 56, 57, 6, 67, 68, 7, 78, 8, 89, 9, 10	BEGIN COMPACTIONS AFTER 24" (600 mm) OF MATERIAL OVER THE CHAMBERS IS REACHED. COMPACT ADDITIONAL LAYERS IN 12" (300 mm) MAX LIFTS TO A MIN. 95% PROCTOR DENSITY FOR WELL GRADED MATERIAL AND 95% RELATIVE DENSITY FOR PROCESSED AGGREGATE MATERIALS.
B	EMBEDMENT STONE: FILL SURROUNDING THE CHAMBERS FROM THE FOUNDATION STONE ('A' LAYER) TO THE 'C' LAYER ABOVE.	CLEAN, CRUSHED, ANGULAR STONE	AASHTO M43' 3, 4	NO COMPACTION REQUIRED.
A	FOUNDATION STONE: FILL BELOW CHAMBERS FROM THE SUBGRADE UP TO THE FOOT (BOTTOM) OF THE CHAMBER.	CLEAN, CRUSHED, ANGULAR STONE	AASHTO M43' 3, 4	PLATE COMPACT OR ROLL TO ACHIEVE A FLAT SURFACE. ^{2,3}

PLEASE NOTE:

- THE LISTED AASHTO DESIGNATIONS ARE FOR GRADATIONS ONLY. THE STONE MUST ALSO BE CLEAN, CRUSHED, ANGULAR. FOR EXAMPLE, A SPECIFICATION FOR #4 STONE WOULD STATE: "CLEAN, CRUSHED, ANGULAR NO. 4 (AASHTO M43) STONE".
- STORMTECH COMPACTION REQUIREMENTS ARE MET FOR 'A' LOCATION MATERIALS WHEN PLACED AND COMPACTED IN 9" (230 mm) (MAX) LIFTS USING TWO FULL COVERAGES WITH A VIBRATORY COMPACTOR.
- WHERE INFILTRATION SURFACES MAY BE COMPROMISED BY COMPACTION, FOR STANDARD DESIGN LOAD CONDITIONS, A FLAT SURFACE MAY BE ACHIEVED BY RAKING OR DRAGGING WITHOUT COMPACTION EQUIPMENT. FOR SPECIAL LOAD DESIGNS, CONTACT STORMTECH FOR COMPACTION REQUIREMENTS.
- ONCE LAYER 'C' IS PLACED, ANY SOIL/MATERIAL CAN BE PLACED IN LAYER 'D' UP TO THE FINISHED GRADE. MOST PAVEMENT SUBBASE SOILS CAN BE USED TO REPLACE THE MATERIAL REQUIREMENTS OF LAYER 'C' OR 'D' AT THE SITE DESIGN ENGINEER'S DISCRETION.

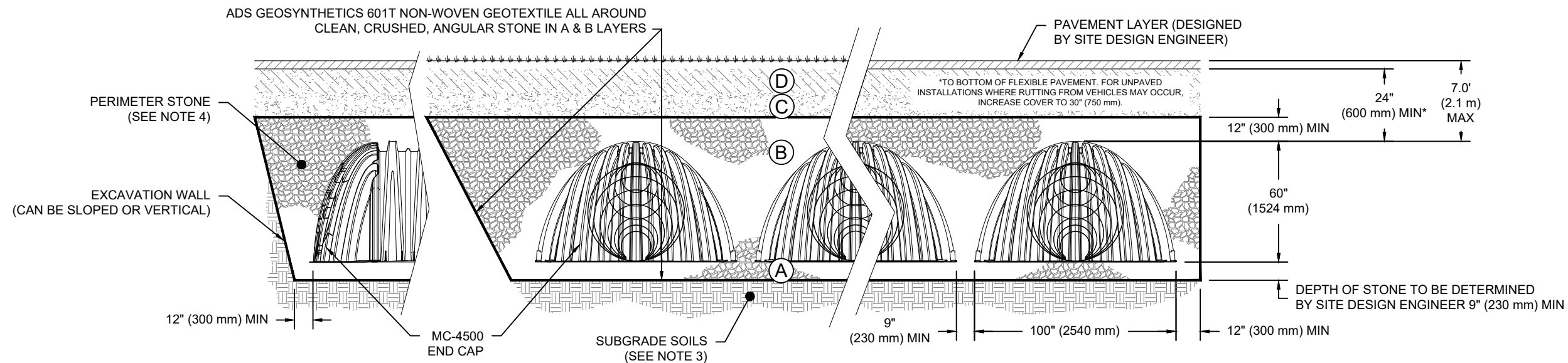

*FOR COVER DEPTHS GREATER THAN 7.0' (2.1 m) PLEASE CONTACT STORMTECH

NOTES:

- CHAMBERS SHALL MEET THE REQUIREMENTS OF ASTM F2418-16a, "STANDARD SPECIFICATION FOR POLYPROPYLENE (PP) CORRUGATED WALL STORMWATER COLLECTION CHAMBERS" CHAMBER CLASSIFICATION 60x101
- MC-4500 CHAMBERS SHALL BE DESIGNED IN ACCORDANCE WITH ASTM F2787 "STANDARD PRACTICE FOR STRUCTURAL DESIGN OF THERMOPLASTIC CORRUGATED WALL STORMWATER COLLECTION CHAMBERS".
- THE SITE DESIGN ENGINEER IS RESPONSIBLE FOR ASSESSING THE BEARING RESISTANCE (ALLOWABLE BEARING CAPACITY) OF THE SUBGRADE SOILS AND THE DEPTH OF FOUNDATION STONE WITH CONSIDERATION FOR THE RANGE OF EXPECTED SOIL MOISTURE CONDITIONS.
- PERIMETER STONE MUST BE EXTENDED HORIZONTALLY TO THE EXCAVATION WALL FOR BOTH VERTICAL AND SLOPED EXCAVATION WALLS.
- REQUIREMENTS FOR HANDLING AND INSTALLATION:
 - TO MAINTAIN THE WIDTH OF CHAMBERS DURING SHIPPING AND HANDLING, CHAMBERS SHALL HAVE INTEGRAL, INTERLOCKING STACKING LUGS.
 - TO ENSURE A SECURE JOINT DURING INSTALLATION AND BACKFILL, THE HEIGHT OF THE CHAMBER JOINT SHALL NOT BE LESS THAN 3".
 - TO ENSURE THE INTEGRITY OF THE ARCH SHAPE DURING INSTALLATION, a) THE ARCH STIFFNESS CONSTANT AS DEFINED IN SECTION 6.2.8 OF ASTM F2418 SHALL BE GREATER THAN OR EQUAL TO 500 LBS/IN/IN. AND b) TO RESIST CHAMBER DEFORMATION DURING INSTALLATION AT ELEVATED TEMPERATURES (ABOVE 73° F / 23° C), CHAMBERS SHALL BE PRODUCED FROM REFLECTIVE GOLD OR YELLOW COLORS.

STANDARD CROSS SECTION	DATE: 05-10-19	DRAWN: KR
	PROJECT #:	CHECKED: KR

MC-4500	DESCRIPTION
	DATE
	DRWN
	CHKD

StormTech
 Determination. Retention. Water Quality.
 70 INWOOD ROAD, SUITE 3 | ROCKY HILL | CT | 06867
 860-525-8188 | 888-892-2694 | WWW.STORMTECH.COM

ADS
 ADVANCED DRAINAGE SYSTEMS, INC.
 4640 TRUEMAN BLVD
 HILLIARD, OH 43026

THIS DRAWING HAS BEEN PREPARED BASED ON INFORMATION PROVIDED TO ADS UNDER THE DIRECTION OF THE SITE DESIGN ENGINEER OR OTHER PROJECT REPRESENTATIVE. THE SITE DESIGN ENGINEER SHALL REVIEW THIS DRAWING PRIOR TO CONSTRUCTION. IT IS THE ULTIMATE RESPONSIBILITY OF THE SITE DESIGN ENGINEER TO ENSURE THAT THE PRODUCT(S) DEPICTED AND ALL ASSOCIATED DETAILS MEET ALL APPLICABLE LAWS, REGULATIONS, AND PROJECT REQUIREMENTS.

PROJECT INFORMATION	
ENGINEERED PRODUCT MANAGER	
ADS SALES REP	
PROJECT NO.	



SiteASSIST™
FOR STORMTECH
INSTRUCTIONS,
DOWNLOAD THE
INSTALLATION APP



772 WINSTON CHURCHILL

OAKVILLE, CANADA, ONTARIO

MC-4500 STORMTECH CHAMBER SPECIFICATIONS

- CHAMBERS SHALL BE STORMTECH MC-4500.
- CHAMBERS SHALL BE ARCH-SHAPED AND SHALL BE MANUFACTURED FROM VIRGIN, IMPACT-MODIFIED POLYPROPYLENE COPOLYMERS.
- CHAMBERS SHALL BE CERTIFIED TO CSA B184, "POLYMERIC SUB-SURFACE STORMWATER MANAGEMENT STRUCTURES", AND MEET THE REQUIREMENTS OF ASTM F2418-16a, "STANDARD SPECIFICATION FOR POLYPROPYLENE (PP) CORRUGATED WALL STORMWATER COLLECTION CHAMBERS" CHAMBER CLASSIFICATION 60x101.
- CHAMBER ROWS SHALL PROVIDE CONTINUOUS, UNOBSTRUCTED INTERNAL SPACE WITH NO INTERNAL SUPPORTS THAT WOULD IMPEDE FLOW OR LIMIT ACCESS FOR INSPECTION.
- THE STRUCTURAL DESIGN OF THE CHAMBERS, THE STRUCTURAL BACKFILL, AND THE INSTALLATION REQUIREMENTS SHALL ENSURE THAT THE LOAD FACTORS SPECIFIED IN THE AASHTO LRFD BRIDGE DESIGN SPECIFICATIONS, SECTION 12.12, ARE MET FOR: 1) LONG-DURATION DEAD LOADS AND 2) SHORT-DURATION LIVE LOADS, BASED ON THE CSA S6 CL-625 TRUCK AND THE AASHTO DESIGN TRUCK WITH CONSIDERATION FOR IMPACT AND MULTIPLE VEHICLE PRESENCES.
- CHAMBERS SHALL BE DESIGNED, TESTED AND ALLOWABLE LOAD CONFIGURATIONS DETERMINED IN ACCORDANCE WITH ASTM F2787, "STANDARD PRACTICE FOR STRUCTURAL DESIGN OF THERMOPLASTIC CORRUGATED WALL STORMWATER COLLECTION CHAMBERS". LOAD CONFIGURATIONS SHALL INCLUDE: 1) INSTANTANEOUS (<1 MIN) AASHTO DESIGN TRUCK LIVE LOAD ON MINIMUM COVER 2) MAXIMUM PERMANENT (75-YR) COVER LOAD AND 3) ALLOWABLE COVER WITH PARKED (1-WEEK) AASHTO DESIGN TRUCK.
- REQUIREMENTS FOR HANDLING AND INSTALLATION:
 - TO MAINTAIN THE WIDTH OF CHAMBERS DURING SHIPPING AND HANDLING, CHAMBERS SHALL HAVE INTEGRAL, INTERLOCKING STACKING LUGS.
 - TO ENSURE A SECURE JOINT DURING INSTALLATION AND BACKFILL, THE HEIGHT OF THE CHAMBER JOINT SHALL NOT BE LESS THAN 75 mm (3").
 - TO ENSURE THE INTEGRITY OF THE ARCH SHAPE DURING INSTALLATION, a) THE ARCH STIFFNESS CONSTANT AS DEFINED IN SECTION 6.2.8 OF ASTM F2418 SHALL BE GREATER THAN OR EQUAL TO 500 LBS/IN/IN. AND b) TO RESIST CHAMBER DEFORMATION DURING INSTALLATION AT ELEVATED TEMPERATURES (ABOVE 23° C / 73° F), CHAMBERS SHALL BE PRODUCED FROM REFLECTIVE GOLD OR YELLOW COLORS.
- ONLY CHAMBERS THAT ARE APPROVED BY THE SITE DESIGN ENGINEER WILL BE ALLOWED. UPON REQUEST BY THE SITE DESIGN ENGINEER OR OWNER, THE CHAMBER MANUFACTURER SHALL SUBMIT A STRUCTURAL EVALUATION FOR APPROVAL BEFORE DELIVERING CHAMBERS TO THE PROJECT SITE AS FOLLOWS:
 - THE STRUCTURAL EVALUATION SHALL BE SEALED BY A REGISTERED PROFESSIONAL ENGINEER.
 - THE STRUCTURAL EVALUATION SHALL DEMONSTRATE THAT THE SAFETY FACTORS ARE GREATER THAN OR EQUAL TO 1.95 FOR DEAD LOAD AND 1.75 FOR LIVE LOAD, THE MINIMUM REQUIRED BY ASTM F2787 AND BY SECTIONS 3 AND 12.12 OF THE AASHTO LRFD BRIDGE DESIGN SPECIFICATIONS FOR THERMOPLASTIC PIPE.
 - THE TEST DERIVED CREEP MODULUS AS SPECIFIED IN ASTM F2418 SHALL BE USED FOR PERMANENT DEAD LOAD DESIGN EXCEPT THAT IT SHALL BE THE 75-YEAR MODULUS USED FOR DESIGN.
- CHAMBERS AND END CAPS SHALL BE PRODUCED AT AN ISO 9001 CERTIFIED MANUFACTURING FACILITY.

IMPORTANT - NOTES FOR THE BIDDING AND INSTALLATION OF MC-4500 CHAMBER SYSTEM

- STORMTECH MC-4500 CHAMBERS SHALL NOT BE INSTALLED UNTIL THE MANUFACTURER'S REPRESENTATIVE HAS COMPLETED A PRE-CONSTRUCTION MEETING WITH THE INSTALLERS.
- STORMTECH MC-4500 CHAMBERS SHALL BE INSTALLED IN ACCORDANCE WITH THE "STORMTECH MC-3500/MC-4500 CONSTRUCTION GUIDE".
- CHAMBERS ARE NOT TO BE BACKFILLED WITH A DOZER OR EXCAVATOR SITUATED OVER THE CHAMBERS. STORMTECH RECOMMENDS 3 BACKFILL METHODS:
 - STONESHOOTER LOCATED OFF THE CHAMBER BED.
 - BACKFILL AS ROWS ARE BUILT USING AN EXCAVATOR ON THE FOUNDATION STONE OR SUBGRADE.
 - BACKFILL FROM OUTSIDE THE EXCAVATION USING A LONG BOOM HOE OR EXCAVATOR.
- THE FOUNDATION STONE SHALL BE LEVELED AND COMPACTED PRIOR TO PLACING CHAMBERS.
- JOINTS BETWEEN CHAMBERS SHALL BE PROPERLY SEATED PRIOR TO PLACING STONE.
- MAINTAIN MINIMUM - 230 mm (9") SPACING BETWEEN THE CHAMBER ROWS.
- INLET AND OUTLET MANIFOLDS MUST BE INSERTED A MINIMUM OF 300 mm (12") INTO CHAMBER END CAPS.
- EMBEDMENT STONE SURROUNDING CHAMBERS MUST BE A CLEAN, CRUSHED, ANGULAR STONE WELL GRADED BETWEEN ¾" AND 2" (20-50 mm).
- STONE SHALL BE BROUGHT UP EVENLY AROUND CHAMBERS SO AS NOT TO DISTORT THE CHAMBER SHAPE. STONE DEPTHS SHOULD NEVER DIFFER BY MORE THAN 300 mm (12") BETWEEN ADJACENT CHAMBER ROWS.
- STONE MUST BE PLACED ON THE TOP CENTER OF THE CHAMBER TO ANCHOR THE CHAMBERS IN PLACE AND PRESERVE ROW SPACING.
- THE CONTRACTOR MUST REPORT ANY DISCREPANCIES WITH CHAMBER FOUNDATION MATERIAL BEARING CAPACITIES TO THE SITE DESIGN ENGINEER.
- ADS RECOMMENDS THE USE OF "FLEXSTORM CATCH IT" INSERTS DURING CONSTRUCTION FOR ALL INLETS TO PROTECT THE SUBSURFACE STORMWATER MANAGEMENT SYSTEM FROM CONSTRUCTION SITE RUNOFF.

NOTES FOR CONSTRUCTION EQUIPMENT



- STORMTECH MC-4500 CHAMBERS SHALL BE INSTALLED IN ACCORDANCE WITH THE "STORMTECH MC-3500/MC-4500 CONSTRUCTION GUIDE".
- THE USE OF EQUIPMENT OVER MC-4500 CHAMBERS IS LIMITED:
 - NO EQUIPMENT IS ALLOWED ON BARE CHAMBERS.
 - NO RUBBER TIRE LOADER, DUMP TRUCK, OR EXCAVATORS ARE ALLOWED UNTIL PROPER FILL DEPTHS ARE REACHED IN ACCORDANCE WITH THE "STORMTECH MC-3500/MC-4500 CONSTRUCTION GUIDE".
 - WEIGHT LIMITS FOR CONSTRUCTION EQUIPMENT CAN BE FOUND IN THE "STORMTECH MC-3500/MC-4500 CONSTRUCTION GUIDE".
- FULL 900 mm (36") OF STABILIZED COVER MATERIALS OVER THE CHAMBERS IS REQUIRED FOR DUMP TRUCK TRAVEL OR DUMPING.

USE OF A DOZER TO PUSH EMBEDMENT STONE BETWEEN THE ROWS OF CHAMBERS MAY CAUSE DAMAGE TO CHAMBERS AND IS NOT AN ACCEPTABLE BACKFILL METHOD. ANY CHAMBERS DAMAGED BY USING THE "DUMP AND PUSH" METHOD ARE NOT COVERED UNDER THE STORMTECH STANDARD WARRANTY.

CONTACT STORMTECH AT 1-888-892-2694 WITH ANY QUESTIONS ON INSTALLATION REQUIREMENTS OR WEIGHT LIMITS FOR CONSTRUCTION EQUIPMENT.

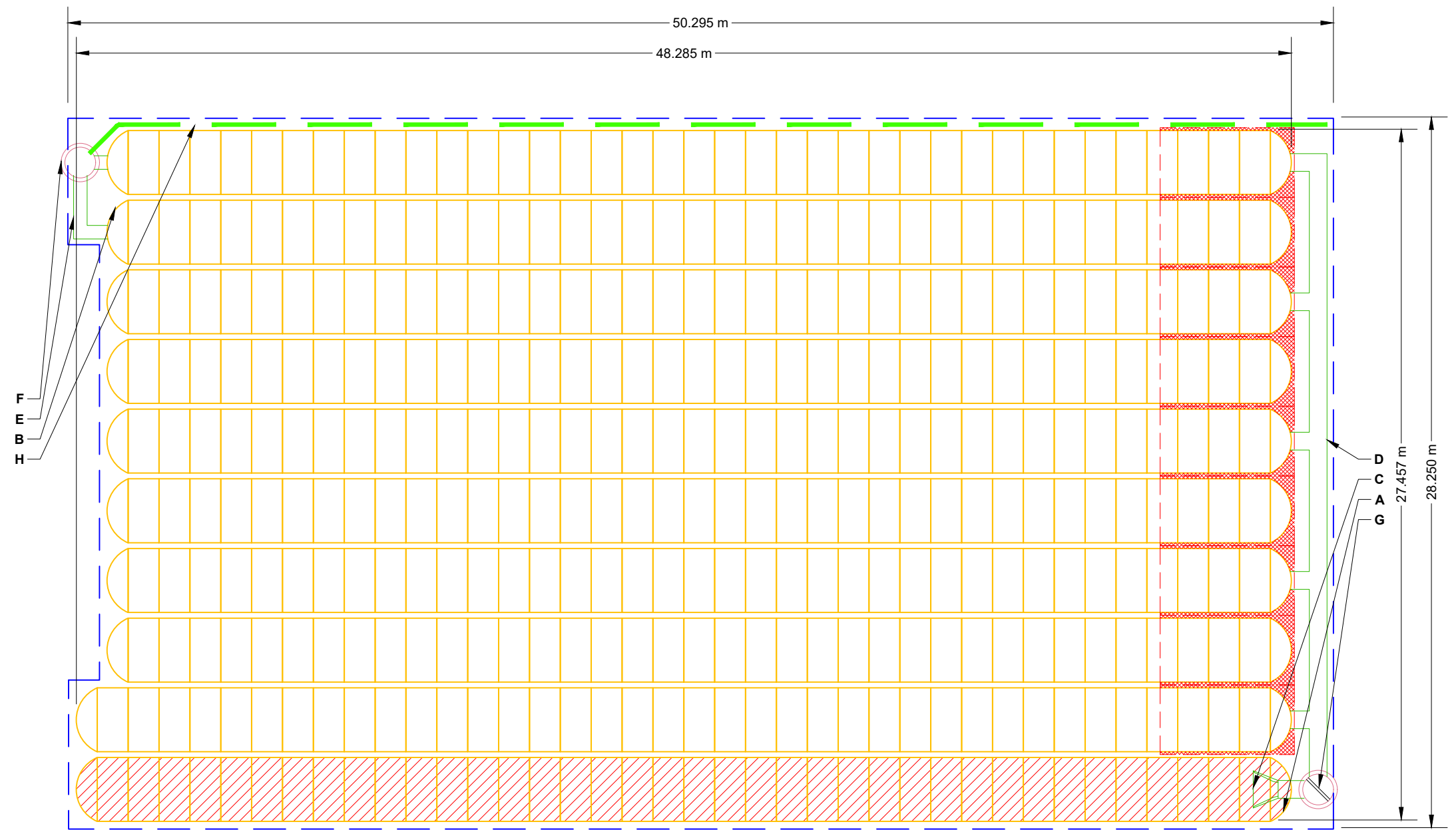
PROPOSED LAYOUT		PROPOSED ELEVATIONS		*INVERT ABOVE BASE OF CHAMBER				
372	STORMTECH MC-4500 CHAMBERS	MAXIMUM ALLOWABLE GRADE (TOP OF PAVEMENT/UNPAVED):	93.886	PART TYPE	ITEM ON LAYOUT	DESCRIPTION	INVERT*	MAX FLOW
20	STORMTECH MC-4500 END CAPS	MINIMUM ALLOWABLE GRADE (UNPAVED WITH TRAFFIC):	92.515					
305	STONE ABOVE (mm)	MINIMUM ALLOWABLE GRADE (UNPAVED NO TRAFFIC):	92.362	PREFABRICATED END CAP	A	600 mm BOTTOM PARTIAL CUT END CAP, PART#: MC4500IEPP24B / TYP OF ALL 600 mm BOTTOM CONNECTIONS AND ISOLATOR PLUS ROWS	57 mm	
229	STONE BELOW (mm)	MINIMUM ALLOWABLE GRADE (TOP OF RIGID CONCRETE PAVEMENT):	92.362	PREFABRICATED END CAP	B	450 mm BOTTOM PARTIAL CUT END CAP, PART#: MC4500IEPP18B / TYP OF ALL 450 mm BOTTOM CONNECTIONS	50 mm	
40	STONE VOID	MINIMUM ALLOWABLE GRADE (BASE OF FLEXIBLE PAVEMENT):	92.362	FLAMP	C	INSTALL FLAMP ON 600 mm ACCESS PIPE / PART#: MC450024RAMP (TYP 2 PLACES)		
1837.8	INSTALLED SYSTEM VOLUME (m ³) (PERIMETER STONE INCLUDED) (COVER STONE INCLUDED) (BASE STONE INCLUDED)	TOP OF STONE:	92.058	MANIFOLD	D	600 mm x 600 mm BOTTOM MANIFOLD, ADS N-12	57 mm	
		TOP OF MC-4500 CHAMBER:	91.753	MANIFOLD	E	450 mm x 450 mm BOTTOM MANIFOLD, ADS N-12	50 mm	
		600 mm x 600 mm BOTTOM MANIFOLD INVERT:	90.286	CONCRETE STRUCTURE	F	OCS (DESIGN BY ENGINEER / PROVIDED BY OTHERS)		227 L/s OUT
		600 mm ISOLATOR ROW PLUS INVERT:	90.286	CONCRETE STRUCTURE	G	(DESIGN BY ENGINEER / PROVIDED BY OTHERS)		1174 L/s IN
1398.8	SYSTEM AREA (m ²)	450 mm x 450 mm BOTTOM MANIFOLD INVERT:	90.279	UNDERDRAIN	H	150 mm ADS N-12 DUAL WALL PERFORATED HDPE UNDERDRAIN		
159.5	SYSTEM PERIMETER (m)	450 mm BOTTOM CONNECTION INVERT:	90.279					
		BOTTOM OF MC-4500 CHAMBER:	90.229					
		UNDERDRAIN INVERT:	90.000					
		BOTTOM OF STONE:	90.000					



-  ISOLATOR ROW PLUS (SEE DETAIL)
-  PLACE MINIMUM 5.334 m OF ADSPLUS175 WOVEN GEOTEXTILE OVER BEDDING STONE AND UNDERNEATH CHAMBER FEET FOR SCOUR PROTECTION AT ALL CHAMBER INLET ROWS
-  BED LIMITS

NOTES

- MANIFOLD SIZE TO BE DETERMINED BY SITE DESIGN ENGINEER. SEE TECH NOTE #6.32 FOR MANIFOLD SIZING GUIDANCE.
- DUE TO THE ADAPTATION OF THIS CHAMBER SYSTEM TO SPECIFIC SITE AND DESIGN CONSTRAINTS, IT MAY BE NECESSARY TO CUT AND COUPLE ADDITIONAL PIPE TO STANDARD MANIFOLD COMPONENTS IN THE FIELD.
- THE SITE DESIGN ENGINEER MUST REVIEW ELEVATIONS AND IF NECESSARY ADJUST GRADING TO ENSURE THE CHAMBER COVER REQUIREMENTS ARE MET.
- THIS CHAMBER SYSTEM WAS DESIGNED WITHOUT SITE-SPECIFIC INFORMATION ON SOIL CONDITIONS OR BEARING CAPACITY. THE SITE DESIGN ENGINEER IS RESPONSIBLE FOR DETERMINING THE SUITABILITY OF THE SOIL AND PROVIDING THE BEARING CAPACITY OF THE INSITU SOILS. THE BASE STONE DEPTH MAY BE INCREASED OR DECREASED ONCE THIS INFORMATION IS PROVIDED.
- **NOT FOR CONSTRUCTION:** THIS LAYOUT IS FOR DIMENSIONAL PURPOSES ONLY TO PROVE CONCEPT & THE REQUIRED STORAGE VOLUME CAN BE ACHIEVED ON SITE.

772 WINSTON CHURCHILL
OAKVILLE, CANADA, ONTARIO

DATE: _____ DRAWN: FP
PROJECT #: _____ CHECKED: N/A

StormTech®
Chamber System

888-892-2694 | WWW.STORMTECH.COM

4640 TRUEMAN BLVD
HILLIARD, OH 43026
1-800-733-7473

SCALE = 1 : 200

SHEET
2 OF 5

THIS DRAWING HAS BEEN PREPARED BASED ON INFORMATION PROVIDED TO ADS UNDER THE DIRECTION OF THE SITE DESIGN ENGINEER OR OTHER PROJECT REPRESENTATIVE. THE SITE DESIGN ENGINEER SHALL REVIEW THIS DRAWING PRIOR TO CONSTRUCTION. IT IS THE ULTIMATE RESPONSIBILITY OF THE SITE DESIGN ENGINEER TO ENSURE THAT THE PRODUCT(S) DEPICTED AND ALL ASSOCIATED DETAILS MEET ALL APPLICABLE LAWS, REGULATIONS, AND PROJECT REQUIREMENTS.

ACCEPTABLE FILL MATERIALS: STORMTECH MC-4500 CHAMBER SYSTEMS

MATERIAL LOCATION		DESCRIPTION	AASHTO MATERIAL CLASSIFICATIONS	COMPACTION / DENSITY REQUIREMENT
D	FINAL FILL: FILL MATERIAL FOR LAYER 'D' STARTS FROM THE TOP OF THE 'C' LAYER TO THE BOTTOM OF FLEXIBLE PAVEMENT OR UNPAVED FINISHED GRADE ABOVE. NOTE THAT PAVEMENT SUBBASE MAY BE PART OF THE 'D' LAYER	ANY SOIL/ROCK MATERIALS, NATIVE SOILS, OR PER ENGINEER'S PLANS. CHECK PLANS FOR PAVEMENT SUBGRADE REQUIREMENTS.	N/A	PREPARE PER SITE DESIGN ENGINEER'S PLANS. PAVED INSTALLATIONS MAY HAVE STRINGENT MATERIAL AND PREPARATION REQUIREMENTS.
C	INITIAL FILL: FILL MATERIAL FOR LAYER 'C' STARTS FROM THE TOP OF THE EMBEDMENT STONE ('B' LAYER) TO 24" (600 mm) ABOVE THE TOP OF THE CHAMBER. NOTE THAT PAVEMENT SUBBASE MAY BE A PART OF THE 'C' LAYER.	GRANULAR WELL-GRADED SOIL/AGGREGATE MIXTURES, <35% FINES OR PROCESSED AGGREGATE. MOST PAVEMENT SUBBASE MATERIALS CAN BE USED IN LIEU OF THIS LAYER.	AASHTO M145 ¹ A-1, A-2-4, A-3 OR AASHTO M43 ¹ 3, 357, 4, 467, 5, 56, 57, 6, 67, 68, 7, 78, 8, 89, 9, 10	BEGIN COMPACTIONS AFTER 24" (600 mm) OF MATERIAL OVER THE CHAMBERS IS REACHED. COMPACT ADDITIONAL LAYERS IN 12" (300 mm) MAX LIFTS TO A MIN. 95% PROCTOR DENSITY FOR WELL GRADED MATERIAL AND 95% RELATIVE DENSITY FOR PROCESSED AGGREGATE MATERIALS.
B	EMBEDMENT STONE: FILL SURROUNDING THE CHAMBERS FROM THE FOUNDATION STONE ('A' LAYER) TO THE 'C' LAYER ABOVE.	CLEAN, CRUSHED, ANGULAR STONE	AASHTO M43 ¹ 3, 4	NO COMPACTION REQUIRED.
A	FOUNDATION STONE: FILL BELOW CHAMBERS FROM THE SUBGRADE UP TO THE FOOT (BOTTOM) OF THE CHAMBER.	CLEAN, CRUSHED, ANGULAR STONE	AASHTO M43 ¹ 3, 4	PLATE COMPACT OR ROLL TO ACHIEVE A FLAT SURFACE. ^{2,3}

PLEASE NOTE:

- THE LISTED AASHTO DESIGNATIONS ARE FOR GRADATIONS ONLY. THE STONE MUST ALSO BE CLEAN, CRUSHED, ANGULAR. FOR EXAMPLE, A SPECIFICATION FOR #4 STONE WOULD STATE: "CLEAN, CRUSHED, ANGULAR NO. 4 (AASHTO M43) STONE".
- STORMTECH COMPACTION REQUIREMENTS ARE MET FOR 'A' LOCATION MATERIALS WHEN PLACED AND COMPACTED IN 9" (230 mm) (MAX) LIFTS USING TWO FULL COVERAGES WITH A VIBRATORY COMPACTOR.
- WHERE INFILTRATION SURFACES MAY BE COMPROMISED BY COMPACTION, FOR STANDARD DESIGN LOAD CONDITIONS, A FLAT SURFACE MAY BE ACHIEVED BY RAKING OR DRAGGING WITHOUT COMPACTION EQUIPMENT. FOR SPECIAL LOAD DESIGNS, CONTACT STORMTECH FOR COMPACTION REQUIREMENTS.
- ONCE LAYER 'C' IS PLACED, ANY SOIL/MATERIAL CAN BE PLACED IN LAYER 'D' UP TO THE FINISHED GRADE. MOST PAVEMENT SUBBASE SOILS CAN BE USED TO REPLACE THE MATERIAL REQUIREMENTS OF LAYER 'C' OR 'D' AT THE SITE DESIGN ENGINEER'S DISCRETION.

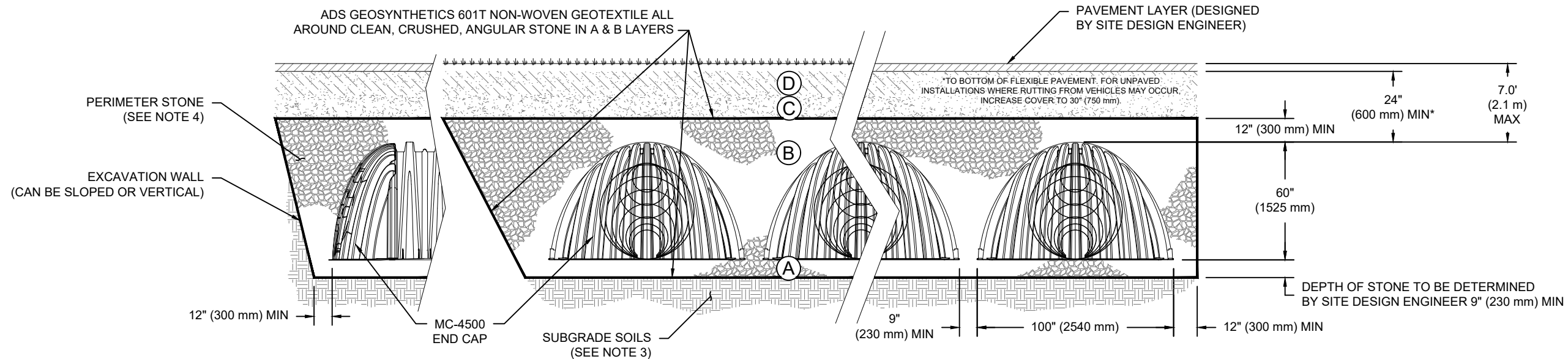

NOTES:

- CHAMBERS SHALL MEET THE REQUIREMENTS OF ASTM F2418-16a, "STANDARD SPECIFICATION FOR POLYPROPYLENE (PP) CORRUGATED WALL STORMWATER COLLECTION CHAMBERS" CHAMBER CLASSIFICATION 60x101
- MC-4500 CHAMBERS SHALL BE DESIGNED IN ACCORDANCE WITH ASTM F2787 "STANDARD PRACTICE FOR STRUCTURAL DESIGN OF THERMOPLASTIC CORRUGATED WALL STORMWATER COLLECTION CHAMBERS".
- THE SITE DESIGN ENGINEER IS RESPONSIBLE FOR ASSESSING THE BEARING RESISTANCE (ALLOWABLE BEARING CAPACITY) OF THE SUBGRADE SOILS AND THE DEPTH OF FOUNDATION STONE WITH CONSIDERATION FOR THE RANGE OF EXPECTED SOIL MOISTURE CONDITIONS.
- PERIMETER STONE MUST BE EXTENDED HORIZONTALLY TO THE EXCAVATION WALL FOR BOTH VERTICAL AND SLOPED EXCAVATION WALLS.
- REQUIREMENTS FOR HANDLING AND INSTALLATION:
 - TO MAINTAIN THE WIDTH OF CHAMBERS DURING SHIPPING AND HANDLING, CHAMBERS SHALL HAVE INTEGRAL, INTERLOCKING STACKING LUGS.
 - TO ENSURE A SECURE JOINT DURING INSTALLATION AND BACKFILL, THE HEIGHT OF THE CHAMBER JOINT SHALL NOT BE LESS THAN 3".
 - TO ENSURE THE INTEGRITY OF THE ARCH SHAPE DURING INSTALLATION, a) THE ARCH STIFFNESS CONSTANT AS DEFINED IN SECTION 6.2.8 OF ASTM F2418 SHALL BE GREATER THAN OR EQUAL TO 500 LBS/IN/IN. AND b) TO RESIST CHAMBER DEFORMATION DURING INSTALLATION AT ELEVATED TEMPERATURES (ABOVE 73° F / 23° C), CHAMBERS SHALL BE PRODUCED FROM REFLECTIVE GOLD OR YELLOW COLORS.

772 WINSTON CHURCHILL

OAKVILLE, CANADA, ONTARIO
DATE: _____
DRAWN: FP
PROJECT #: _____
CHECKED: N/A

DATE	DRW	CHK	DESCRIPTION

StormTech®
Chamber System

888-892-2694 | WWW.STORMTECH.COM

4640 TRUEMAN BLVD
HILLIARD, OH 43026
1-800-733-7473

THIS DRAWING HAS BEEN PREPARED BASED ON INFORMATION PROVIDED TO ADS UNDER THE DIRECTION OF THE SITE DESIGN ENGINEER OR OTHER PROJECT REPRESENTATIVE. THE SITE DESIGN ENGINEER SHALL REVIEW THIS DRAWING PRIOR TO CONSTRUCTION. IT IS THE ULTIMATE RESPONSIBILITY OF THE SITE DESIGN ENGINEER TO ENSURE THAT THE PRODUCT(S) DEPICTED AND ALL ASSOCIATED DETAILS MEET ALL APPLICABLE LAWS, REGULATIONS, AND PROJECT REQUIREMENTS.

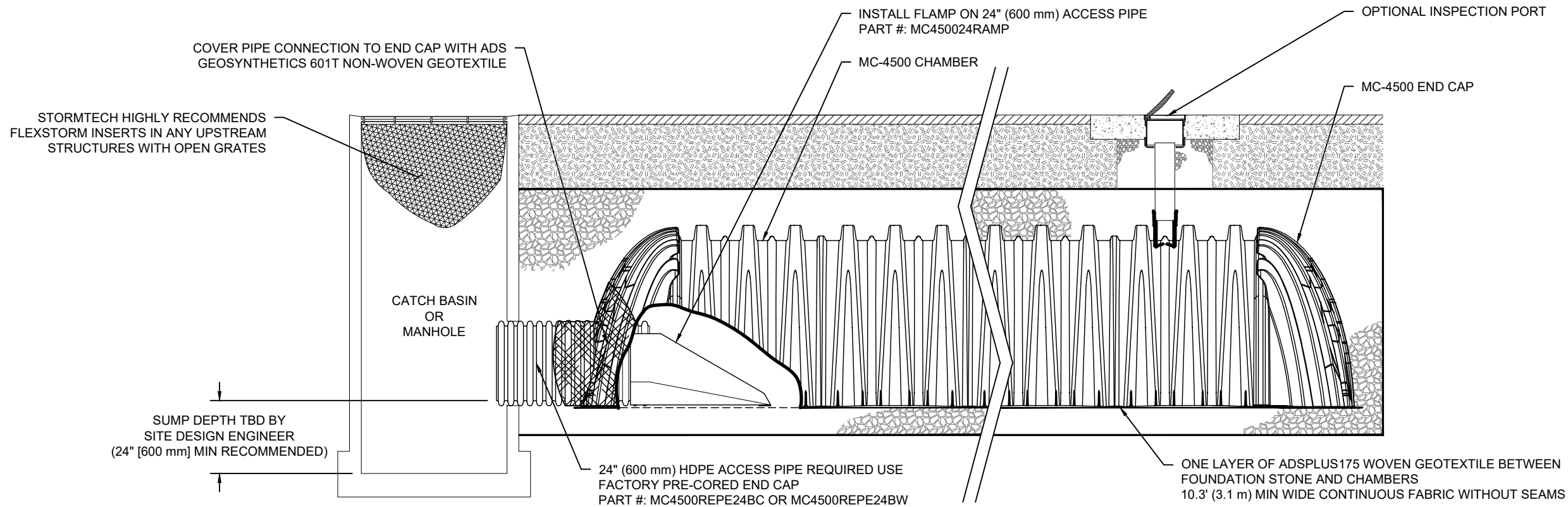

MC-4500 ISOLATOR ROW PLUS DETAIL

NTS

INSPECTION & MAINTENANCE

- STEP 1) INSPECT ISOLATOR ROW PLUS FOR SEDIMENT
- A. INSPECTION PORTS (IF PRESENT)
 - A.1. REMOVE/OPEN LID ON NYLOPLAST INLINE DRAIN
 - A.2. REMOVE AND CLEAN FLEXSTORM FILTER IF INSTALLED
 - A.3. USING A FLASHLIGHT AND STADIA ROD, MEASURE DEPTH OF SEDIMENT AND RECORD ON MAINTENANCE LOG
 - A.4. LOWER A CAMERA INTO ISOLATOR ROW PLUS FOR VISUAL INSPECTION OF SEDIMENT LEVELS (OPTIONAL)
 - A.5. IF SEDIMENT IS AT, OR ABOVE, 3" (80 mm) PROCEED TO STEP 2. IF NOT, PROCEED TO STEP 3.
 - B. ALL ISOLATOR PLUS ROWS
 - B.1. REMOVE COVER FROM STRUCTURE AT UPSTREAM END OF ISOLATOR ROW PLUS
 - B.2. USING A FLASHLIGHT, INSPECT DOWN THE ISOLATOR ROW PLUS THROUGH OUTLET PIPE
 - i) MIRRORS ON POLES OR CAMERAS MAY BE USED TO AVOID A CONFINED SPACE ENTRY
 - ii) FOLLOW OSHA REGULATIONS FOR CONFINED SPACE ENTRY IF ENTERING MANHOLE
 - B.3. IF SEDIMENT IS AT, OR ABOVE, 3" (80 mm) PROCEED TO STEP 2. IF NOT, PROCEED TO STEP 3.
- STEP 2) CLEAN OUT ISOLATOR ROW PLUS USING THE JETVAC PROCESS
- A. A FIXED CULVERT CLEANING NOZZLE WITH REAR FACING SPREAD OF 45" (1.1 m) OR MORE IS PREFERRED
 - B. APPLY MULTIPLE PASSES OF JETVAC UNTIL BACKFLUSH WATER IS CLEAN
 - C. VACUUM STRUCTURE SUMP AS REQUIRED
- STEP 3) REPLACE ALL COVERS, GRATES, FILTERS, AND LIDS; RECORD OBSERVATIONS AND ACTIONS.
- STEP 4) INSPECT AND CLEAN BASINS AND MANHOLES UPSTREAM OF THE STORMTECH SYSTEM.

NOTES

1. INSPECT EVERY 6 MONTHS DURING THE FIRST YEAR OF OPERATION. ADJUST THE INSPECTION INTERVAL BASED ON PREVIOUS OBSERVATIONS OF SEDIMENT ACCUMULATION AND HIGH WATER ELEVATIONS.
2. CONDUCT JETTING AND VACTORING ANNUALLY OR WHEN INSPECTION SHOWS THAT MAINTENANCE IS NECESSARY.

772 WINSTON CHURCHILL OAKVILLE, CANADA, ONTARIO		DATE:	DRAWN: FP	PROJECT #:	CHECKED: N/A
StormTech® Chamber System 888-892-2694 WWW.STORMTECH.COM		THIS DRAWING HAS BEEN PREPARED BASED ON INFORMATION PROVIDED TO ADS UNDER THE DIRECTION OF THE SITE DESIGN ENGINEER OR OTHER PROJECT REPRESENTATIVE. THE SITE DESIGN ENGINEER SHALL REVIEW THIS DRAWING PRIOR TO CONSTRUCTION. IT IS THE ULTIMATE RESPONSIBILITY OF THE SITE DESIGN ENGINEER TO ENSURE THAT THE PRODUCT(S) DEPICTED AND ALL ASSOCIATED DETAILS MEET ALL APPLICABLE LAWS, REGULATIONS, AND PROJECT REQUIREMENTS.			
4640 TRUEMAN BLVD HILLIARD, OH 43026 1-800-733-7473					
SHEET 4 OF 5					

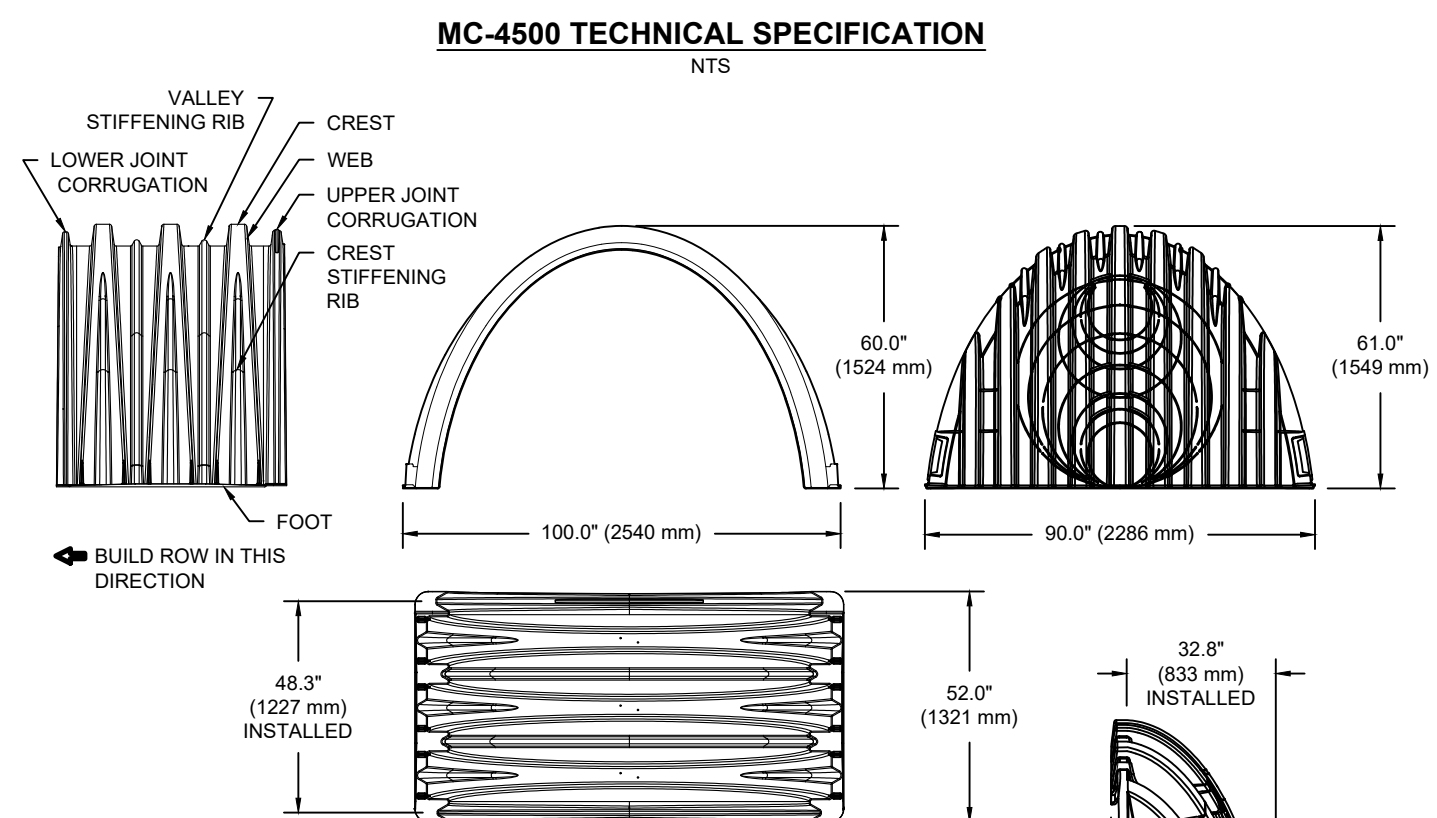
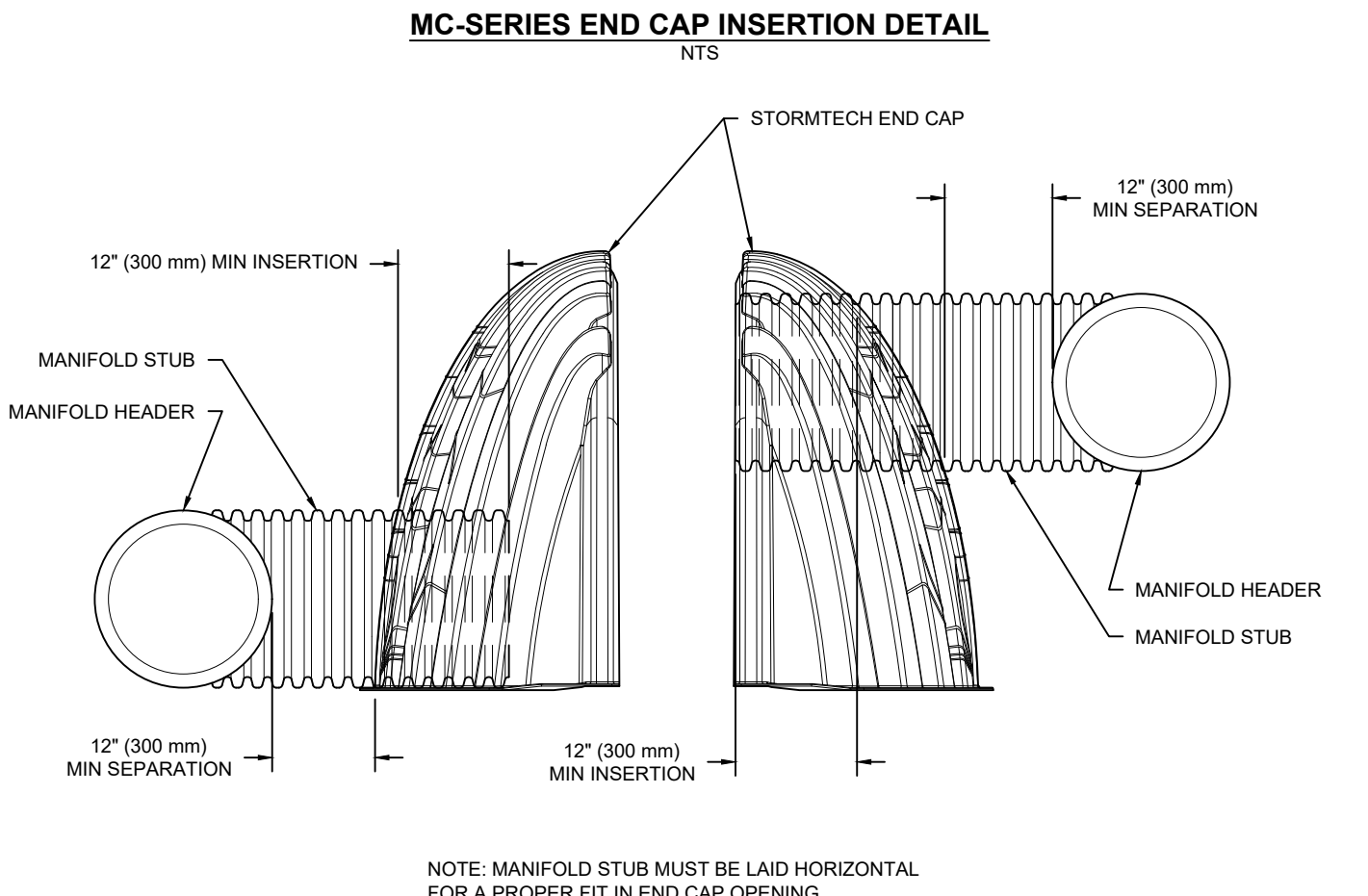
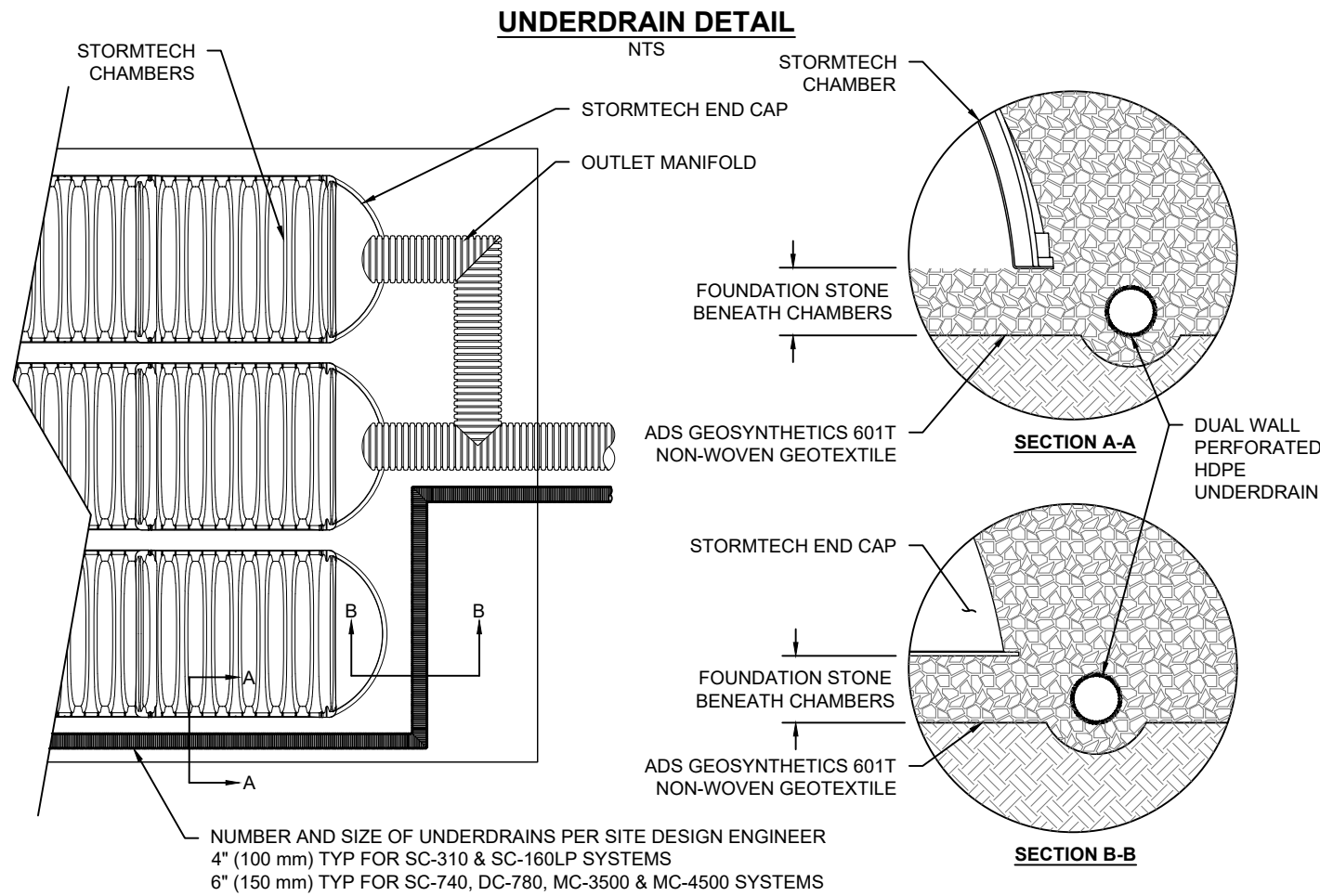

NOMINAL CHAMBER SPECIFICATIONS

SIZE (W X H X INSTALLED LENGTH)	100.0" X 60.0" X 48.3"	(2540 mm X 1524 mm X 1227 mm)
CHAMBER STORAGE	106.5 CUBIC FEET	(3.01 m ³)
MINIMUM INSTALLED STORAGE*	162.6 CUBIC FEET	(4.60 m ³)
WEIGHT (NOMINAL)	125.0 lbs.	(56.7 kg)

NOMINAL END CAP SPECIFICATIONS

SIZE (W X H X INSTALLED LENGTH)	90.0" X 61.0" X 32.8"	(2286 mm X 1549 mm X 833 mm)
END CAP STORAGE	39.5 CUBIC FEET	(1.12 m ³)
MINIMUM INSTALLED STORAGE*	115.3 CUBIC FEET	(3.26 m ³)
WEIGHT (NOMINAL)	90 lbs.	(40.8 kg)

*ASSUMES 12" (305 mm) STONE ABOVE, 9" (229 mm) STONE FOUNDATION AND BETWEEN CHAMBERS, 12" (305 mm) STONE PERIMETER IN FRONT OF END CAPS AND 40% STONE POROSITY.

PARTIAL CUT HOLES AT BOTTOM OF END CAP FOR PART NUMBERS ENDING WITH "B"
 PARTIAL CUT HOLES AT TOP OF END CAP FOR PART NUMBERS ENDING WITH "T"
 END CAPS WITH A PREFABRICATED WELDED STUB END WITH "W"

PART #	STUB	B	C
MC4500IEPP06T	6" (150 mm)	42.54" (1081 mm)	---
MC4500IEPP06B		---	0.86" (22 mm)
MC4500IEPP08T	8" (200 mm)	40.50" (1029 mm)	---
MC4500IEPP08B		---	1.01" (26 mm)
MC4500IEPP10T	10" (250 mm)	38.37" (975 mm)	---
MC4500IEPP10B		---	1.33" (34 mm)
MC4500IEPP12T	12" (300 mm)	35.69" (907 mm)	---
MC4500IEPP12B		---	1.55" (39 mm)
MC4500IEPP15T	15" (375 mm)	32.72" (831 mm)	---
MC4500IEPP15B		---	1.70" (43 mm)
MC4500IEPP18T	18" (450 mm)	29.36" (746 mm)	---
MC4500IEPP18TW		---	1.97" (50 mm)
MC4500IEPP18B		---	---
MC4500IEPP18BW		---	---
MC4500IEPP24T	24" (600 mm)	23.05" (585 mm)	---
MC4500IEPP24TW		---	2.26" (57 mm)
MC4500IEPP24B	---	---	---
MC4500IEPP24BW	---	---	---
MC4500IEPP30BW	30" (750 mm)	---	2.95" (75 mm)
MC4500IEPP36BW	36" (900 mm)	---	3.25" (83 mm)
MC4500IEPP42BW	42" (1050 mm)	---	3.55" (90 mm)

NOTE: ALL DIMENSIONS ARE NOMINAL

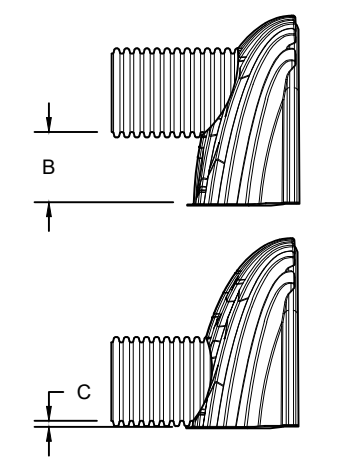

CUSTOM PARTIAL CUT INVERTS ARE AVAILABLE UPON REQUEST. INVENTORIED MANIFOLDS INCLUDE 12-24" (300-600 mm) SIZE ON SIZE AND 15-48" (375-1200 mm) ECCENTRIC MANIFOLDS. CUSTOM INVERT LOCATIONS ON THE MC-4500 END CAP CUT IN THE FIELD ARE NOT RECOMMENDED FOR PIPE SIZES GREATER THAN 10" (250 mm). THE INVERT LOCATION IN COLUMN 'B' ARE THE HIGHEST POSSIBLE FOR THE PIPE SIZE.

772 WINSTON CHURCHILL
 OAKVILLE, CANADA, ONTARIO

DATE: _____ DRAWN: FP
 PROJECT #: _____ CHECKED: N/A

DESCRIPTION

DATE

DRW

CHK

DATE

DRW

CHK

StormTech®
Chamber System

888-892-2694 | WWW.STORMTECH.COM

4640 TRUEMAN BLVD
 HILLIARD, OH 43026
 1-800-733-7473

SHEET
 5 OF 5

THIS DRAWING HAS BEEN PREPARED BASED ON INFORMATION PROVIDED TO ADS UNDER THE DIRECTION OF THE SITE DESIGN ENGINEER OR OTHER PROJECT REPRESENTATIVE. THE SITE DESIGN ENGINEER SHALL REVIEW THIS DRAWING PRIOR TO CONSTRUCTION. IT IS THE ULTIMATE RESPONSIBILITY OF THE SITE DESIGN ENGINEER TO ENSURE THAT THE PRODUCT(S) DEPICTED AND ALL ASSOCIATED DETAILS MEET ALL APPLICABLE LAWS, REGULATIONS, AND PROJECT REQUIREMENTS.

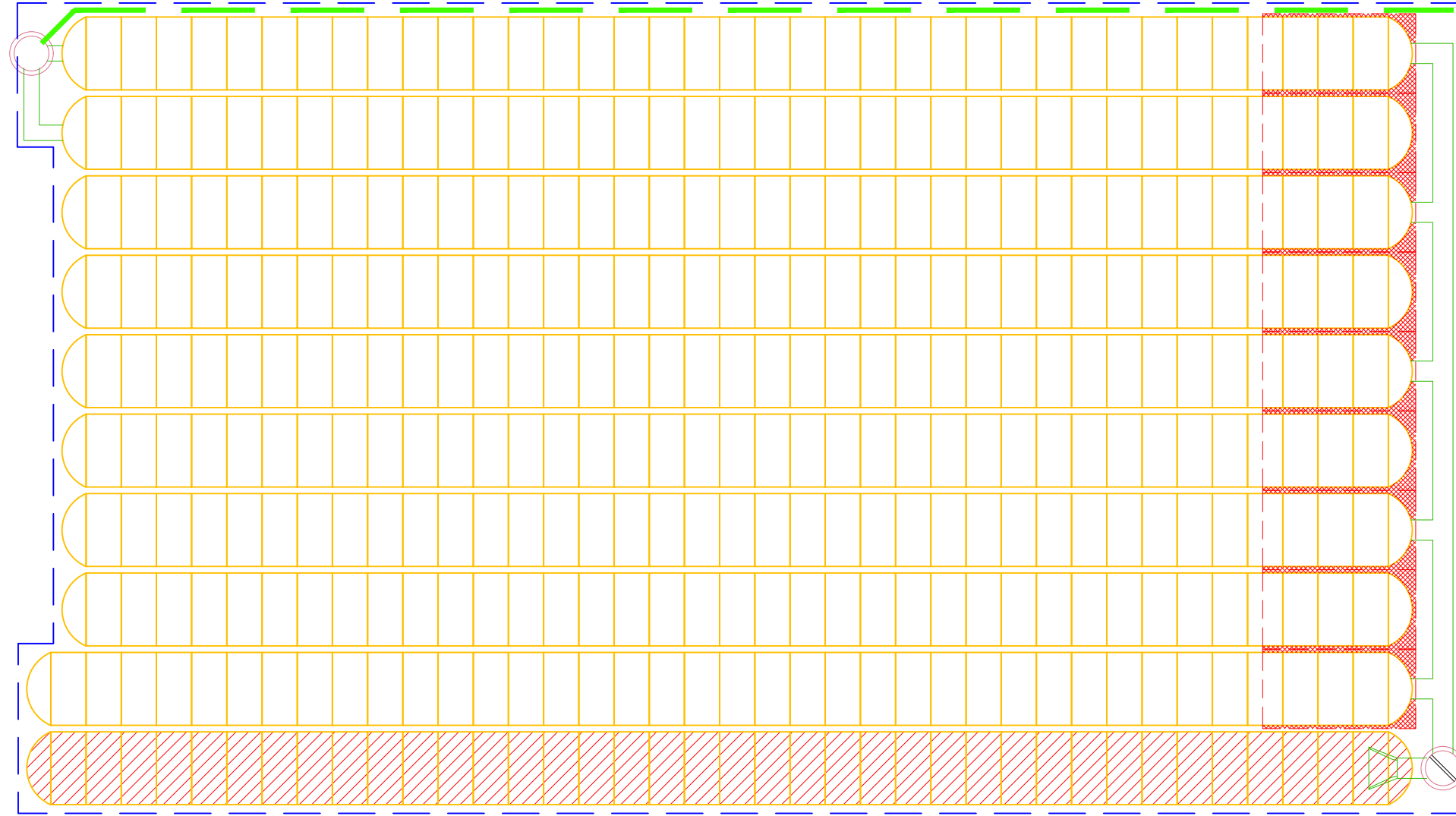

APPENDIX C
SWMHYMO OUTPUT

PRE-DEVELOPMENT
TARGET FLOW
SWMHYMO OUTPUT

```

=====
SSSSS W W M M H H Y Y M M O O O 999 999
S W W M M H H Y Y M M M M O O 9 9 9 9
SSSSS W W M M H H H H Y Y M M O O ## 9 9 9 9 Ver. 4.02
S W W M M H H Y Y M M O O 999 999 July 1999
SSSSS W W M M H H Y Y M M O O 9 9 9 9
StormWater Management Hydrologic Model
999 999 # 3813174
=====

```

```

*****
***** SWHMHYMO-99 Ver/4.02 *****
***** A single event and continuous hydrologic simulation model *****
***** based on the principles of HYMO and its successors *****
***** OTHYMO-83 and OTHYMO-89. *****
***** Distributed by: J.F. Sabourin and Associates Inc. *****
***** Ottawa, Ontario: (613) 727-5199 *****
***** Gatineau, Quebec: (819) 243-6858 *****
***** E-Mail: swmhymo@jfsa.Com *****
*****
+++++ Licensed user: A.M. Candaras Associates Inc. +++++
+++++ Woodbridge SERIAL#: 3813174 +++++
*****
***** +++++ PROGRAM ARRAY DIMENSIONS +++++ *****
***** Maximum value for ID numbers : 10 *****
***** Max. number of rainfall points: 15000 *****
***** Max. number of flow points : 15000 *****
*****
*****
***** D E T A I L E D O U T P U T *****
*****
DATE: 2021-09-13 TIME: 14:29:16 RUN COUNTER: 000270
*
* Input filename: C:\PROGRA-1\SWHMHYMO\Projects\2060\2060PreB.dat
* Output filename: C:\PROGRA-1\SWHMHYMO\Projects\2060\2060PreB.out
* Summary filename: C:\PROGRA-1\SWHMHYMO\Projects\2060\2060PreB.sum
* User comments:
* 1:
* 2:
* 3:
*****

```

```

001:0001-----
## Project Name: 772 Winston Churchill Blvd., Oakville
## Project Number: 2060
## Date : 2021-09-10
## Modeller : F. Petkovski, P.Eng.
## Company : a.m. candaras associates inc.
## License # : 3813174
*****
| START | Project dir.: C:\PROGRA-1\SWHMHYMO\Projects\2060\

```

```

----- Rainfall dir.: C:\PROGRA-1\SWHMHYMO\Projects\2060\
TZERO = .00 hrs on
METOUT= 2 (output = METRIC)
NRUN = 001
NSTORM= 1
# 1=CHIC25MM.STM
-----
001:0002-----
*

```

Filename: C:\PROGRA-1\SWHMHYMO\Projects\2060\CHIC25
Comments: *BLOOR ST STAT DATA 10 MIN DISCRITIZATIO

READ STORM		RAIN		TIME		RAIN		TIME		RAIN		TIME	
Ptotal= 25.00 mm		hrs	mm/hr	hrs	mm/hr	hrs	mm/hr	hrs	mm/hr	hrs	mm/hr	hrs	mm/hr
.08	1.624	1.08	12.284	2.08	3.786	3.08	1.940	3.17	1.940	3.17	1.940	3.17	1.940
.25	1.853	1.25	58.772	2.25	3.233	3.25	1.803	3.25	3.233	3.25	1.803	3.25	1.803
.42	2.170	1.42	16.185	2.42	2.838	3.42	1.688	3.42	2.838	3.42	1.688	3.42	1.688
.50	2.170	1.50	16.185	2.50	2.838	3.50	1.688	3.50	2.838	3.50	1.688	3.50	1.688
.67	2.651	1.67	8.549	2.67	2.529	3.67	1.588	3.67	2.529	3.67	1.588	3.67	1.588
.75	3.470	1.75	5.927	2.75	2.292	3.75	1.501	3.75	2.292	3.75	1.501	3.75	1.501
.83	3.470	1.83	5.927	2.83	2.292	3.83	1.501	3.83	2.292	3.83	1.501	3.83	1.501
.92	5.201	1.92	4.598	2.92	2.098	3.92	1.422	3.92	2.098	3.92	1.422	3.92	1.422
1.00	5.201	2.00	4.598	3.00	2.098	4.00	1.422	4.00	2.098	4.00	1.422	4.00	1.422

```

001:0003-----
* SUB-CATCHMENT 5 - PRE-DEVELOPMENT FLOW RATES
* BASED ON AREA OF 24.2 ha
*****
| CALIB NASHYD | Area (ha)= 24.20 | Curve Number (CN)=70.00
| 01:000100 DT= 5.00 | Ia (mm)= 7.000 | # of Linear Res.(N)= 3.00
|-----| U.H. Tp(hrs)= .820
Unit Hyd Qpeak (cms) = 1.127
PEAK FLOW (cms) = .067 (i)
TIME TO PEAK (hrs) = 2.583
RUNOFF VOLUME (mm) = 2.554
TOTAL RAINFALL (mm) = 25.000
RUNOFF COEFFICIENT = .102
(i) PEAK FLOW DOES NOT INCLUDE BASEFLOW IF ANY.

```

```

001:0004-----
** END OF RUN : 1
*****

```



```

-----
| START | Project dir.: C:\PROGRA-1\SWHMYM\Projects\2060\
|-----| Rainfall dir.: C:\PROGRA-1\SWHMYM\Projects\2060\
|-----|
TZERO = .00 hrs on
METOUT= 2 (output = METRIC)
NRUN = 002
NSTORM= 1
# I=CHIC2YR.STM

002:0002-----
** Project Name: 772 Winston Churchill Blvd., Oakville
** Project Number: 2060
** Date : 2021-09-10
** Modeller : F. Petkovski, P.Eng.
** Company : a.m. candaras associates inc.
** License # : 3813174
**
002:0002-----
*

```

Filename: C:\PROGRA-1\SWHMYM\Projects\2060\CHIC2Y
Comments: *BLOOR ST STAT DATA 10 MIN DISCRITIZATIO

TIME	RAIN	TIME	RAIN	TIME	RAIN	TIME	RAIN
hrs	mm/hr	hrs	mm/hr	hrs	mm/hr	hrs	mm/hr
.08	2.260	1.08	17.100	2.08	5.270	3.08	2.700
.17	2.260	1.17	17.100	2.17	5.270	3.17	2.700
.25	2.580	1.25	81.810	2.25	4.500	3.25	2.510
.33	2.580	1.33	81.810	2.33	4.500	3.33	2.510
.42	3.020	1.42	22.530	2.42	3.950	3.42	2.350
.50	3.020	1.50	22.530	2.50	3.950	3.50	2.350
.58	3.690	1.58	11.900	2.58	3.520	3.58	2.210
.67	3.690	1.67	11.900	2.67	3.520	3.67	2.210
.75	4.830	1.75	8.250	2.75	3.190	3.75	2.090
.83	4.830	1.83	8.250	2.83	3.190	3.83	2.090
.92	7.240	1.92	6.400	2.92	2.920	3.92	1.980
1.00	7.240	2.00	6.400	3.00	2.920	4.00	1.980

```

-----
002:0003-----
** SUB-CATCHMENT 5 - PRE-DEVELOPMENT FLOW RATES
** BASED ON AREA OF 24.2 ha
**
CALIB NASHYD | Area (ha)= 24.20 | Curve Number (CN)=70.00
| 01:000100 DT= 5.00 | Ia (mm)= 7.000 | # of Linear Res.(N)= 3.00
|-----| U.H. Tp(hrs)= .820
Unit Hyd Qpeak (cms) = 1.127
PEAK FLOW (cms) = .155 (i)
TIME TO PEAK (hrs) = 2.417
RUNOFF VOLUME (mm) = 5.655
TOTAL RAINFALL (mm) = 34.800
RUNOFF COEFFICIENT = .163
(i) PEAK FLOW DOES NOT INCLUDE BASEFLOW IF ANY.

```

```

-----
002:0004-----
** Project Name: 772 Winston Churchill Blvd., Oakville
** Project Number: 2060
** Date : 2021-09-10
** Modeller : F. Petkovski, P.Eng.
** Company : a.m. candaras associates inc.
** License # : 3813174
**
002:0002-----
** END OF RUN : 2

```

Filename: C:\PROGRA-1\SWHMYM\Projects\2060\CHIC5Y
Comments: *BLOOR ST STAT DATA 10 MIN DISCRITIZATIO

TIME	RAIN	TIME	RAIN	TIME	RAIN	TIME	RAIN
hrs	mm/hr	hrs	mm/hr	hrs	mm/hr	hrs	mm/hr
.08	2.820	1.08	22.680	2.08	6.740	3.08	3.400
.17	2.820	1.17	22.680	2.17	6.740	3.17	3.400
.25	3.240	1.25	113.160	2.25	5.730	3.25	3.150
.33	3.240	1.33	113.160	2.33	5.730	3.33	3.150
.42	3.810	1.42	30.090	2.42	5.010	3.42	2.950
.50	3.810	1.50	30.090	2.50	5.010	3.50	2.950
.58	4.680	1.58	15.580	2.58	4.460	3.58	2.770
.67	4.680	1.67	15.580	2.67	4.460	3.67	2.770
.75	6.160	1.75	10.690	2.75	4.030	3.75	2.610
.83	6.160	1.83	10.690	2.83	4.030	3.83	2.610
.92	9.350	1.92	8.230	2.92	3.680	3.92	2.480
1.00	9.350	2.00	8.230	3.00	3.680	4.00	2.480

```

-----
003:0003-----
** SUB-CATCHMENT 5 - PRE-DEVELOPMENT FLOW RATES
** BASED ON AREA OF 24.2 ha

```

```

-----
| CALIB NASHYD | Area (ha)= 24.20 | Curve Number (CN)=70.00
| 01:000100 DT= 5.00 | Ia (mm)= 7.000 | # of Linear Res.(N)= 3.00
|-----|-----|-----
| U.H. Tp(hrs)= .820
Unit Hyd Qpeak (cms)= 1.127
PEAK FLOW (cms)= .300 (i)
TIME TO PEAK (hrs)= 2.417
RUNOFF VOLUME (mm)= 10.402
TOTAL RAINFALL (mm)= 46.250
RUNOFF COEFFICIENT = .225

```

(i) PEAK FLOW DOES NOT INCLUDE BASEFLOW IF ANY.

```

003:0004-----
*****
* SUB-CATCHMENT 5 - PRE-DEVELOPMENT FLOW RATES
* BASED ON AREA OF 24.2 ha
*****
003:0002-----
-----
003:0002-----
** END OF RUN : 3

```

```

*****
Unit Hyd Qpeak (cms)= 1.127
PEAK FLOW (cms)= .413 (i)
TIME TO PEAK (hrs)= 2.333
RUNOFF VOLUME (mm)= 14.245
TOTAL RAINFALL (mm)= 54.140
RUNOFF COEFFICIENT = .263
(i) PEAK FLOW DOES NOT INCLUDE BASEFLOW IF ANY.
004:0004-----
*****
004:0002-----
004:0002-----
004:0002-----
** END OF RUN : 4

```

```

*****
Project Name: 772 Winston Churchill Blvd., Oakville
Project Number: 2060
Date : 2021-09-10
Modeller : F. Petkovski, P.Eng.
Company : a.m. candaras associates inc.
License # : 3813174
*****
004:0002-----
*

```

```

-----
| READ STORM | Filename: C:\PROGRA-1\SWHMYM\Projects\2060\CHIC10
| Ptotal= 54.14 mm | Comments: *BLOOR ST STAT DATA 10 MIN DISCRITIZATIO
-----
| TIME | RAIN | TIME | TIME | RAIN | TIME | RAIN |
| hrs | mm/hr | hrs | hrs | mm/hr | hrs | mm/hr |
|.08 | 3.410 | 1.08 | 2.08 | 7.880 | 3.08 | 4.080 |
|.17 | 3.410 | 1.17 | 2.17 | 7.880 | 3.17 | 4.080 |
|.25 | 3.890 | 1.25 | 2.25 | 6.750 | 3.25 | 3.800 |

```

```

.33 3.890 | 1.33 135.630 | 2.33 | 6.750 | 3.33 3.800
.42 4.560 | 1.42 33.220 | 2.42 | 5.930 | 3.42 3.560
.50 4.560 | 1.50 33.220 | 2.50 | 5.930 | 3.50 3.560
.58 5.550 | 1.58 17.550 | 2.58 | 5.300 | 3.58 3.350
.67 5.550 | 1.67 17.550 | 2.67 | 5.300 | 3.67 3.350
.75 7.230 | 1.75 12.240 | 2.75 | 4.810 | 3.75 3.160
.83 7.230 | 1.83 12.240 | 2.83 | 4.810 | 3.83 3.160
.92 10.770 | 1.92 9.540 | 2.92 | 4.410 | 3.92 3.000
1.00 10.770 | 2.00 9.540 | 3.00 | 4.410 | 4.00 3.000

```

```

004:0003-----
*****
* SUB-CATCHMENT 5 - PRE-DEVELOPMENT FLOW RATES
* BASED ON AREA OF 24.2 ha
*****

```

```

| CALIB NASHYD | Area (ha)= 24.20 | Curve Number (CN)=70.00
| 01:000100 DT= 5.00 | Ia (mm)= 7.000 | # of Linear Res.(N)= 3.00
|-----|-----|-----
| U.H. Tp(hrs)= .820

```

```

Unit Hyd Qpeak (cms)= 1.127
PEAK FLOW (cms)= .413 (i)
TIME TO PEAK (hrs)= 2.333
RUNOFF VOLUME (mm)= 14.245
TOTAL RAINFALL (mm)= 54.140
RUNOFF COEFFICIENT = .263

```

(i) PEAK FLOW DOES NOT INCLUDE BASEFLOW IF ANY.

```

004:0004-----
*****
004:0002-----
004:0002-----
004:0002-----
** END OF RUN : 4

```

```

*****
Project Name: 772 Winston Churchill Blvd., Oakville
Project Number: 2060
Date : 2021-09-10
Modeller : F. Petkovski, P.Eng.
Company : a.m. candaras associates inc.
License # : 3813174
*****

```

```

-----
| START | Project dir.: C:\PROGRA-1\SWHMYM\Projects\2060\
|-----|-----|-----|-----|-----|-----|-----|-----|
| TZERO = .00 hrs on | Rainfall dir.: C:\PROGRA-1\SWHMYM\Projects\2060\
| METOUT= 2 (output = METRIC)
| NRUN = 005
| NSTORM= 1
|-----|-----|-----|-----|-----|-----|-----|-----|
| # 1=CHIC25YR.STM

```

```

005:0002-----
*****
** Project Name: 772 Winston Churchill Blvd., Oakville

```

** Project Number: 2060
** Date : 2021-09-10
** Modeller : F. Petkovski, P.Eng.
** Company : a.m. candaras associates inc.
** License # : 3813174

005:0002-----
*
| READ STORM | Filename: C:\PROGRA~1\SWMHYMO\Projects\2060\CHIC25
| Ptotal= 62.16 mm | Comments: *BLOOR ST STAT DATA 10 MIN DISCRITIZATIO

Table with 10 columns: TIME, RAIN, TIME, RAIN, TIME, RAIN, TIME, RAIN, TIME, RAIN. Rows include peak flow data and runoff volume/coefficients.

005:0003-----
*
| CALIB NASHYD | Area (ha)= 24.20 Curve Number (CN)=70.00
| 01:000100 DT= 5.00 | Ia (mm)= 7.000 # of Linear Res.(N)= 3.00

Unit Hyd Qpeak (cms) = 1.127
PEAK FLOW (cms) = .540 (i)
TIME TO PEAK (hrs) = 2.333
RUNOFF VOLUME (mm) = 18.550
TOTAL RAINFALL (mm) = 62.158
RUNOFF COEFFICIENT = .298
(i) PEAK FLOW DOES NOT INCLUDE BASEFLOW IF ANY.

005:0004-----
*
| CALIB NASHYD | Area (ha) = 24.20 Curve Number (CN)=70.00
| 01:000100 DT= 5.00 | Ia (mm)= 7.000 # of Linear Res.(N)= 3.00

Unit Hyd Qpeak (cms) = 1.127
Area (ha) = 24.20 Curve Number (CN)=70.00
Ia (mm) = 7.000 # of Linear Res.(N)= 3.00
U.H. Tp(hrs) = .820

** END OF RUN : 5

| START | Project dir.: C:\PROGRA~1\SWMHYMO\Projects\2060\
| Rainfall dir.: C:\PROGRA~1\SWMHYMO\Projects\2060\

006:0002-----
*
| READ STORM | Filename: C:\PROGRA~1\SWMHYMO\Projects\2060\CHIC50
| Ptotal= 70.32 mm | Comments: *BLOOR ST STAT DATA 10 MIN DISCRITIZATIO

Table with 10 columns: TIME, RAIN, TIME, RAIN, TIME, RAIN, TIME, RAIN, TIME, RAIN. Rows include peak flow data and runoff volume/coefficients.

006:0003-----
*
| CALIB NASHYD | Area (ha) = 24.20 Curve Number (CN)=70.00
| 01:000100 DT= 5.00 | Ia (mm)= 7.000 # of Linear Res.(N)= 3.00

Unit Hyd Qpeak (cms) = 1.127
Area (ha) = 24.20 Curve Number (CN)=70.00
Ia (mm) = 7.000 # of Linear Res.(N)= 3.00
U.H. Tp(hrs) = .820

006:0004-----
*
| CALIB NASHYD | Area (ha) = 24.20 Curve Number (CN)=70.00
| 01:000100 DT= 5.00 | Ia (mm)= 7.000 # of Linear Res.(N)= 3.00

Unit Hyd Qpeak (cms) = 1.127
Area (ha) = 24.20 Curve Number (CN)=70.00
Ia (mm) = 7.000 # of Linear Res.(N)= 3.00
U.H. Tp(hrs) = .820

PEAK FLOW (cms) = .706 (i)
TIME TO PEAK (hrs) = 2.333
RUNOFF VOLUME (mm) = 23.284
TOTAL RAINFALL (mm) = 70.316
RUNOFF COEFFICIENT = .331

(i) PEAK FLOW DOES NOT INCLUDE BASEFLOW IF ANY.

006:0004-----

006:0002-----

006:0002-----

006:0002-----

006:0002-----

006:0002-----

006:0002-----

006:0002-----

006:0002-----

006:0002-----

006:0002-----

006:0002-----

006:0002-----

006:0002-----

** END OF RUN : 6

START | Project dir.: C:\PROGRA-1\SWHMYM\Projects\2060\
Rainfall dir.: C:\PROGRA-1\SWHMYM\Projects\2060\
TZERO = .00 hrs on 0
METOUT= 2 (output = METRIC)
NRUN = 007
NSTORM= 1
1-CHI00YR.STM

007:0002-----

Project Name: 772 Winston Churchill Blvd., Oakville
Project Number: 2060
Date : 2021-09-10
Modeller : F. Petkovski, P.Eng.
Company : a.m. candaras associates inc.
License # : 3813174

007:0002-----
*
READ STORM
Ptotal= 78.03 mm
Filename: C:\PROGRA-1\SWHMYM\Projects\2060\CHI00Y
Comments: *BLOOR ST STAT DATA 10 MIN DISCRITIZATIO

TIME	RAIN	TIME	RAIN	TIME	RAIN	TIME	RAIN
hrs	mm/hr	hrs	mm/hr	hrs	mm/hr	hrs	mm/hr
.08	4.310	1.08	38.040	2.08	10.640	3.08	5.210
.17	4.310	1.17	38.040	2.17	10.640	3.17	5.210
.25	4.960	1.25	203.310	2.25	8.990	3.25	4.830

.33 4.960 | 1.33 203.310 | 2.33 8.990 | 3.33 4.830
.42 5.880 | 1.42 51.040 | 2.42 7.810 | 3.42 4.500
.50 5.880 | 1.50 51.040 | 2.50 7.810 | 3.50 4.500
.58 7.270 | 1.58 25.590 | 2.58 6.920 | 3.58 4.220
.67 7.270 | 1.67 25.590 | 2.67 6.920 | 3.67 4.220
.75 9.690 | 1.75 17.240 | 2.75 6.230 | 3.75 3.970
.83 9.690 | 1.83 17.240 | 2.83 6.230 | 3.83 3.970
.92 15.000 | 1.92 13.110 | 2.92 5.670 | 3.92 3.760
1.00 15.000 | 2.00 13.110 | 3.00 5.670 | 4.00 3.760

007:0003-----

* SUB-CATCHMENT 5 - PRE-DEVELOPMENT FLOW RATES
* BASED ON AREA OF 24.2 ha

CALIB NASHYD | Area (ha) = 24.20 | Curve Number (CN)=70.00
| 01:000100 DT= 5.00 | Ia (mm) = 7.000 | # of Linear Res.(N) = 3.00
| | U.H. Tp(hrs) = .820

Unit Hyd Qpeak (cms) = 1.127
PEAK FLOW (cms) = .869 (i)
TIME TO PEAK (hrs) = 2.333
RUNOFF VOLUME (mm) = 28.048
TOTAL RAINFALL (mm) = 78.032
RUNOFF COEFFICIENT = .359

(i) PEAK FLOW DOES NOT INCLUDE BASEFLOW IF ANY.

007:0004-----

007:0002-----

007:0002-----

007:0002-----

007:0002-----

007:0002-----

007:0002-----

** END OF RUN : 7

START | Project dir.: C:\PROGRA-1\SWHMYM\Projects\2060\
Rainfall dir.: C:\PROGRA-1\SWHMYM\Projects\2060\
TZERO = .00 hrs on 0
METOUT= 2 (output = METRIC)
NRUN = 008

NSTORM= 1
 # 1=2Y24HS.STM

 008:0002-----
 # Project Name: 772 Winston Churchill Blvd., Oakville
 # Project Number: 2060
 # Date : 2021-09-10
 # Modeller : F. Petkovski, P.Eng.
 # Company : a.m. candaras associates inc.
 # License # : 3813174

008:0002-----
*

READ STORM | Filename: C:\PROGRA-1\SWMHYMO\Projects\2060\2Y24HS
 Ptotal= 51.39 mm | Comments: * 2YR SCS 24hr STORM, 15min TIME STEPS,M

TIME	RAIN	TIME	RAIN	TIME	RAIN	TIME	RAIN	TIME	RAIN
hrs	mm/hr	hrs	mm/hr	hrs	mm/hr	hrs	mm/hr	hrs	mm/hr
.25	.570	6.25	1.030	12.25	7.400	18.25	9.20	18.25	7.400
.50	.570	6.50	1.030	12.50	7.400	18.50	9.20	18.50	7.400
.75	.570	6.75	1.030	12.75	3.800	18.75	9.20	18.75	3.800
1.00	.570	7.00	1.030	13.00	3.800	19.00	9.20	19.00	3.800
1.25	.570	7.25	1.030	13.25	7.20	19.25	9.20	19.25	7.20
1.50	.570	7.50	1.030	13.50	7.20	19.50	9.20	19.50	7.20
1.75	.570	7.75	1.030	13.75	4.210	19.75	9.20	19.75	4.210
2.00	.570	8.00	1.030	14.00	4.210	20.00	9.20	20.00	4.210
2.25	.670	8.25	1.390	14.25	1.540	20.25	6.20	20.25	1.540
2.50	.670	8.50	1.390	14.50	1.540	20.50	6.20	20.50	1.540
2.75	.670	8.75	1.390	14.75	1.540	20.75	6.20	20.75	1.540
3.00	.670	9.00	1.390	15.00	1.540	21.00	6.20	21.00	1.540
3.25	.670	9.25	1.640	15.25	1.540	21.25	6.20	21.25	1.640
3.50	.670	9.50	1.640	15.50	1.540	21.50	6.20	21.50	1.640
3.75	.670	9.75	1.850	15.75	1.540	21.75	6.20	21.75	1.850
4.00	.670	10.00	1.850	16.00	1.540	22.00	6.20	22.00	1.850
4.25	.820	10.25	2.360	16.25	9.20	22.25	6.20	22.25	2.360
4.50	.820	10.50	2.360	16.50	9.20	22.50	6.20	22.50	2.360
4.75	.820	10.75	3.190	16.75	9.20	22.75	6.20	22.75	3.190
5.00	.820	11.00	3.190	17.00	9.20	23.00	6.20	23.00	3.190
5.25	.820	11.25	4.930	17.25	9.20	23.25	6.20	23.25	4.930
5.50	.820	11.50	4.930	17.50	9.20	23.50	6.20	23.50	4.930
5.75	.820	11.75	21.380	17.75	9.20	23.75	6.20	23.75	21.380
6.00	.820	12.00	56.730	18.00	9.20	24.00	6.20	24.00	56.730

008:0003-----
 * SUB-CATCHMENT 5 - PRE-DEVELOPMENT FLOW RATES
 * BASED ON AREA OF 24.2 ha

CALIB NASHYD	Area	(ha)=	24.20	Curve Number	(CN)=70.00
01:000100 DT=	5.00	Ia	(mm)=	7.000	# of Linear Res.(N)= 3.00
		U.H. Tp	(hrs)=	.820	

Unit Hyd Qpeak (cms) = 1.127
 PEAK FLOW (cms) = .274 (i)

TIME TO PEAK (hrs)= 12.833
 RUNOFF VOLUME (mm)= 12.857
 TOTAL RAINFALL (mm)= 51.387
 RUNOFF COEFFICIENT = .250

(i) PEAK FLOW DOES NOT INCLUDE BASEFLOW IF ANY.

008:0004-----

008:0002-----

008:0002-----

008:0002-----

008:0002-----

008:0002-----

008:0002-----

008:0002-----

008:0002-----

008:0002-----

008:0002-----

008:0002-----

008:0002-----

008:0002-----

008:0002-----

008:0002-----

008:0002-----

008:0002-----

008:0002-----

008:0002-----

008:0002-----

008:0002-----

008:0002-----

008:0002-----

008:0002-----

008:0002-----

008:0002-----

008:0002-----

008:0002-----

008:0002-----

READ STORM | Filename: C:\PROGRA-1\SWMHYMO\Projects\2060\5Y24HS
 Ptotal= 63.89 mm | Comments: * 5 YEAR SCS 24hr STORM, 15 min TIME STE

TIME	RAIN	TIME	RAIN	TIME	RAIN	TIME	RAIN
hrs	mm/hr	hrs	mm/hr	hrs	mm/hr	hrs	mm/hr
.25	.700	6.25	1.280	12.25	9.200	18.25	1.150

.50	.700	6.50	1.280	12.50	9.200	18.50	1.150
.75	.700	6.75	1.280	12.75	4.730	18.75	1.150
1.00	.700	7.00	1.280	13.00	4.730	19.00	1.150
1.25	.700	7.25	1.280	13.25	.890	19.25	1.150
1.50	.700	7.50	1.280	13.50	1.890	19.50	1.150
1.75	.700	7.75	1.280	13.75	5.240	19.75	1.150
2.00	.700	8.00	1.280	14.00	5.240	20.00	1.150
2.25	.830	8.25	1.720	14.25	1.920	20.25	.770
2.50	.830	8.50	1.720	14.50	1.920	20.50	.770
2.75	.830	8.75	1.720	14.75	1.920	20.75	.770
3.00	.830	9.00	1.720	15.00	1.920	21.00	.770
3.25	.830	9.25	2.040	15.25	1.920	21.25	.770
3.50	.830	9.50	2.040	15.50	1.920	21.50	.770
3.75	.830	9.75	2.300	15.75	1.920	21.75	.770
4.00	.830	10.00	2.300	16.00	1.920	22.00	.770
4.25	1.020	10.25	2.940	16.25	1.150	22.25	.770
4.50	1.020	10.50	2.940	16.50	1.150	22.50	.770
4.75	1.020	10.75	3.960	16.75	1.150	22.75	.770
5.00	1.020	11.00	3.960	17.00	1.150	23.00	.770
5.25	1.020	11.25	6.130	17.25	1.150	23.25	.770
5.50	1.020	11.50	6.130	17.50	1.150	23.50	.770
5.75	1.020	11.75	26.580	17.75	1.150	23.75	.770
6.00	1.020	12.00	70.530	18.00	1.150	24.00	.770

009:0003-----
 * SUB-CATCHMENT 5 - PRE-DEVELOPMENT FLOW RATES
 * BASED ON AREA OF 24.2 ha

CALIB NASHYD | Area (ha)= 24.20 | Curve Number (CN)=70.00
 | 01:000100 DT= 5.00 | Ia (mm)= 7.000 | # of Linear Res.(N)= 3.00
 | | U.H. Tp(hrs)= .820

Unit Hyd Qpeak (cms)= 1.127
 PEAK FLOW (cms)= .424 (i)
 TIME TO PEAK (hrs)= 12.750
 RUNOFF VOLUME (mm)= 19.528
 TOTAL RAINFALL (mm)= 63.893
 RUNOFF COEFFICIENT = .306

(i) PEAK FLOW DOES NOT INCLUDE BASEFLOW IF ANY.

009:0004-----

 009:0002-----
 009:0002-----
 009:0002-----
 009:0002-----
 009:0002-----
 009:0002-----
 009:0002-----
 009:0002-----

009:0002-----
 009:0002-----
 ** END OF RUN : 9

 | START | Project dir.: C:\PROGRA-1\SWHMYM\Projects\2060\
 | | Rainfall dir.: C:\PROGRA-1\SWHMYM\Projects\2060\
 | | TZERO = .00 hrs on 0
 | | METOUT= 2 (output = METRIC)
 | | NRUN = 010
 | | NSTORM= 1
 | | # 1=10Y24HS.STM
 | | *****
 010:0002-----

 ** Project Name: 772 Winston Churchill Blvd., Oakville
 ** Project Number: 2060
 ** Date : 2021-09-10
 ** Modeller : F. Petkovski, P.Eng.
 ** Company : a.m. candaras associates inc.
 ** License # : 3813174

010:0002-----
 *
 | READ STORM | Ptotal= 72.94 mm |
 | |

TIME hrs	RAIN mm/hr	TIME hrs	RAIN mm/hr	TIME hrs	RAIN mm/hr	TIME hrs	RAIN mm/hr
6.25	1.460	12.25	10.500	18.25	1.310	24.25	1.310
6.50	1.460	12.50	10.500	18.50	1.310	24.50	1.310
6.75	1.460	12.75	5.400	18.75	1.310	24.75	1.310
7.00	1.460	13.00	5.400	19.00	1.310	25.00	1.310
7.25	1.460	13.25	1.020	19.25	1.310	25.25	1.310
7.50	1.460	13.50	1.020	19.50	1.310	25.50	1.310
7.75	1.460	13.75	5.980	19.75	1.310	25.75	1.310
8.00	1.460	14.00	5.980	20.00	1.310	26.00	1.310
8.25	1.970	14.25	2.190	20.25	.880	26.25	.880
8.50	1.970	14.50	2.190	20.50	.880	26.50	.880
8.75	1.970	14.75	2.190	20.75	.880	26.75	.880
9.00	1.970	15.00	2.190	21.00	.880	27.00	.880
9.25	2.330	15.25	2.190	21.25	.880	27.25	.880
9.50	2.330	15.50	2.190	21.50	.880	27.50	.880
9.75	2.630	15.75	2.190	21.75	.880	27.75	.880
10.00	2.630	16.00	2.190	22.00	.880	28.00	.880
10.25	3.350	16.25	1.310	22.25	.880	28.25	.880
10.50	3.350	16.50	1.310	22.50	.880	28.50	.880
10.75	4.520	16.75	1.310	22.75	.880	28.75	.880
11.00	4.520	17.00	1.310	23.00	.880	29.00	.880
11.25	7.000	17.25	1.310	23.25	.880	29.25	.880

5.50 1.170 | 11.50 7.000 | 17.50 1.310 | 23.50 .880
 5.75 1.170 | 11.75 30.330 | 17.75 1.310 | 23.75 .880
 6.00 1.170 | 12.00 80.500 | 18.00 1.310 | 24.00 .880

010:0003-----
 * SUB-CATCHMENT 5 - PRE-DEVELOPMENT FLOW RATES
 * BASED ON AREA OF 24.2 ha

 | CALIB NASHYD | Area (ha)= 24.20 | Curve Number (CN)=70.00
 | 01:000100 DT= 5.00 | Ia (mm)= 7.000 | # of Linear Res.(N)= 3.00
 | U.H. Tp(hrs)= .820

Unit Hyd Qpeak (cms) = 1.127
 PEAK FLOW (cms) = .546 (i)
 TIME TO PEAK (hrs) = 12.750
 RUNOFF VOLUME (mm) = 24.877
 TOTAL RAINFALL (mm) = 72.943
 RUNOFF COEFFICIENT = .341

(i) PEAK FLOW DOES NOT INCLUDE BASEFLOW IF ANY.

010:0004-----

010:0002-----

010:0002-----

010:0002-----

010:0002-----

010:0002-----

010:0002-----

010:0002-----

010:0002-----
 ** END OF RUN : 10

 | START | Project dir.: C:\PROGRA-1\SWMHYMO\Projects\2060\
 | TZERO = .00 hrs on Rainfall dir.: C:\PROGRA-1\SWMHYMO\Projects\2060\
 | METOUT= 2 (output = METRIC) 0
 | NRUN = 011

NSTORM= 1
 # 1=25Y24HS.STM

011:0002-----

 * Project Name: 772 Winston Churchill Blvd., Oakville
 * Project Number: 2060
 * Date : 2021-09-10
 * Modeller : F. Petkovski, P.Eng.
 * Company : a.m. candaras associates inc.
 * License # : 3813174

011:0002-----

 | READ STORM | Filename: C:\PROGRA-1\SWMHYMO\Projects\2060\25Y24H
 | Ptotal= 85.25 mm | Comments: * 25 YEAR SCS 24hr STORM, 15 min TIME ST

TIME	RAIN	TIME	RAIN	TIME	RAIN	TIME	RAIN
hrs	mm/hr	hrs	mm/hr	hrs	mm/hr	hrs	mm/hr
.25	.940	6.25	1.710	12.25	12.280	18.25	1.530
.50	.940	6.50	1.710	12.50	12.280	18.50	1.530
.75	.940	6.75	1.710	12.75	6.310	18.75	1.530
1.00	.940	7.00	1.710	13.00	6.310	19.00	1.530
1.25	.940	7.25	1.710	13.25	1.190	19.25	1.530
1.50	.940	7.50	1.710	13.50	1.190	19.50	1.530
1.75	.940	7.75	1.710	13.75	6.990	19.75	1.530
2.00	.940	8.00	1.710	14.00	6.990	20.00	1.530
2.25	1.110	8.25	2.300	14.25	2.560	20.25	1.020
2.50	1.110	8.50	2.300	14.50	2.560	20.50	1.020
2.75	1.110	8.75	2.300	14.75	2.560	20.75	1.020
3.00	1.110	9.00	2.300	15.00	2.560	21.00	1.020
3.25	1.110	9.25	2.730	15.25	2.560	21.25	1.020
3.50	1.110	9.50	2.730	15.50	2.560	21.50	1.020
3.75	1.110	9.75	3.070	15.75	2.560	21.75	1.020
4.00	1.110	10.00	3.070	16.00	2.560	22.00	1.020
4.25	1.360	10.25	3.920	16.25	1.530	22.25	1.020
4.50	1.360	10.50	3.920	16.50	1.530	22.50	1.020
4.75	1.360	10.75	5.290	16.75	1.530	22.75	1.020
5.00	1.360	11.00	5.290	17.00	1.530	23.00	1.020
5.25	1.360	11.25	8.190	17.25	1.530	23.25	1.020
5.50	1.360	11.50	8.190	17.50	1.530	23.50	1.020
5.75	1.360	11.75	35.470	17.75	1.530	23.75	1.020
6.00	1.360	12.00	94.140	18.00	1.530	24.00	1.020

011:0003-----

* SUB-CATCHMENT 5 - PRE-DEVELOPMENT FLOW RATES

* BASED ON AREA OF 24.2 ha

 | CALIB NASHYD | Area (ha)= 24.20 | Curve Number (CN)=70.00
 | 01:000100 DT= 5.00 | Ia (mm)= 7.000 | # of Linear Res.(N)= 3.00
 | U.H. Tp(hrs)= .820

Unit Hyd Qpeak (cms) = 1.127
 PEAK FLOW (cms) = .727 (i)

TIME TO PEAK (hrs)= 12.750
RUNOFF VOLUME (mm)= 32.723
TOTAL RAINFALL (mm)= 85.247
RUNOFF COEFFICIENT = .384

(i) PEAK FLOW DOES NOT INCLUDE BASEFLOW IF ANY.

TIME	RAIN	TIME	RAIN	TIME	RAIN	TIME	RAIN	TIME	RAIN
hrs	mm/hr	hrs	mm/hr	hrs	mm/hr	hrs	mm/hr	hrs	mm/hr
.25	1.020	6.25	1.860	12.25	13.360	18.25	1.670		
.50	1.020	6.50	1.860	12.50	13.360	18.50	1.670		
.75	1.020	6.75	1.860	12.75	6.860	18.75	1.670		
1.00	1.020	7.00	1.860	13.00	6.860	19.00	1.670		
1.25	1.020	7.25	1.860	13.25	1.300	19.25	1.670		
1.50	1.020	7.50	1.860	13.50	1.300	19.50	1.670		
1.75	1.020	7.75	1.860	13.75	7.610	19.75	1.670		
2.00	1.020	8.00	1.860	14.00	7.610	20.00	1.670		
2.25	1.210	8.25	2.500	14.25	2.780	20.25	1.110		
2.50	1.210	8.50	2.500	14.50	2.780	20.50	1.110		
2.75	1.210	8.75	2.500	14.75	2.780	20.75	1.110		
3.00	1.210	9.00	2.500	15.00	2.780	21.00	1.110		
3.25	1.210	9.25	2.970	15.25	2.780	21.25	1.110		
3.50	1.210	9.50	2.970	15.50	2.780	21.50	1.110		
3.75	1.210	9.75	3.340	15.75	2.780	21.75	1.110		
4.00	1.210	10.00	3.340	16.00	2.780	22.00	1.110		
4.25	1.480	10.25	4.270	16.25	1.670	22.25	1.110		
4.50	1.480	10.50	4.270	16.50	1.670	22.50	1.110		
4.75	1.480	10.75	5.750	16.75	1.670	22.75	1.110		
5.00	1.480	11.00	5.750	17.00	1.670	23.00	1.110		
5.25	1.480	11.25	8.910	17.25	1.670	23.25	1.110		
5.50	1.480	11.50	8.910	17.50	1.670	23.50	1.110		
5.75	1.480	11.75	38.590	17.75	1.670	23.75	1.110		
6.00	1.480	12.00	102.410	18.00	1.670	24.00	1.110		

** END OF RUN : 11

| START | Project dir.: C:\PROGRA-1\SWMHYMO\Projects\2060\
|-----| Rainfall dir.: C:\PROGRA-1\SWMHYMO\Projects\2060\
TZERO = .00 hrs on 0
METOUT= 2 (output = METRIC)
NRUN = 012
NSTORM= 1
1-50Y24HS.STM

012:0002-----

Project Name: 772 Winston Churchill Blvd., Oakville
Project Number: 2060
Date : 2021-09-10
Modeller : F. Petkovski, P.Eng.
Company : a.m. candaras associates inc.
License # : 3813174

012:0002-----

| READ STORM | File name: C:\PROGRA-1\SWMHYMO\Projects\2060\50Y24H
|-----| Comments: * 100 YEAR SCS 24hr STORM, 15 min TIME S
| Total= 92.76 mm |

TIME	RAIN	TIME	RAIN	TIME	RAIN	TIME	RAIN	TIME	RAIN
hrs	mm/hr	hrs	mm/hr	hrs	mm/hr	hrs	mm/hr	hrs	mm/hr
.25	1.020	6.25	1.860	12.25	13.360	18.25	1.670		
.50	1.020	6.50	1.860	12.50	13.360	18.50	1.670		
.75	1.020	6.75	1.860	12.75	6.860	18.75	1.670		
1.00	1.020	7.00	1.860	13.00	6.860	19.00	1.670		
1.25	1.020	7.25	1.860	13.25	1.300	19.25	1.670		
1.50	1.020	7.50	1.860	13.50	1.300	19.50	1.670		
1.75	1.020	7.75	1.860	13.75	7.610	19.75	1.670		
2.00	1.020	8.00	1.860	14.00	7.610	20.00	1.670		
2.25	1.210	8.25	2.500	14.25	2.780	20.25	1.110		
2.50	1.210	8.50	2.500	14.50	2.780	20.50	1.110		
2.75	1.210	8.75	2.500	14.75	2.780	20.75	1.110		
3.00	1.210	9.00	2.500	15.00	2.780	21.00	1.110		
3.25	1.210	9.25	2.970	15.25	2.780	21.25	1.110		
3.50	1.210	9.50	2.970	15.50	2.780	21.50	1.110		
3.75	1.210	9.75	3.340	15.75	2.780	21.75	1.110		
4.00	1.210	10.00	3.340	16.00	2.780	22.00	1.110		
4.25	1.480	10.25	4.270	16.25	1.670	22.25	1.110		
4.50	1.480	10.50	4.270	16.50	1.670	22.50	1.110		
4.75	1.480	10.75	5.750	16.75	1.670	22.75	1.110		
5.00	1.480	11.00	5.750	17.00	1.670	23.00	1.110		
5.25	1.480	11.25	8.910	17.25	1.670	23.25	1.110		
5.50	1.480	11.50	8.910	17.50	1.670	23.50	1.110		
5.75	1.480	11.75	38.590	17.75	1.670	23.75	1.110		
6.00	1.480	12.00	102.410	18.00	1.670	24.00	1.110		

012:0003-----

* SUB-CATCHMENT 5 - PRE-DEVELOPMENT FLOW RATES

* BASED ON AREA OF 24.2 ha

| CALIB NASHYD | Area (ha)= 24.20 | Curve Number (CN)=70.00
|-----| Ia (mm)= 7.000 | # of Linear Res.(N)= 3.00
| 01:000100 DT= 5.00 | U.H. Tp(hrs)= .820

Unit Hyd Qpeak (cms)= 1.127

PEAK FLOW (cms)= .843 (i)

TIME TO PEAK (hrs)= 12.750

RUNOFF VOLUME (mm)= 37.788

TOTAL RAINFALL (mm)= 92.755

RUNOFF COEFFICIENT = .407

(i) PEAK FLOW DOES NOT INCLUDE BASEFLOW IF ANY.

012:0004-----

012:0002-----

012:0002-----

012:0002-----

```
-----  
013:0002-----  
-----  
013:0002-----  
FINISH  
*****  
WARNINGS / ERRORS / NOTES  
-----  
Simulation ended on 2021-09-13 at 14:29:16  
=====
```

POST DEVELOPMENT
SWMHYMO OUTPUT

```

2 Metric units
*#*****
*# Project Name: 772 Winston Churchill Blvd., Oakville
*# Project Number: 2256
*# Date : DECEMBER 2022
*# Modeller : FP
*# Company : a.m. candaras associates inc.
*# License # : 3813174
*# Revision : C
*#*****
START
TZERO=[0.0], METOUT=[2], NSTORM=[2], NRUN=[1], NRUN= [001]
"CHIC25MM.STM"
STORM_FILENAME= ["storm.001"]

```

```

*#*****
*# SITE 772 WINSTON CHURCHILL*
*#*****
*# PAVED AREAS AND LANDSCAPED AREAS
CALIB STANDHYD
ID=[1], NHYD=[001], DT=[1] (min), AREA=[5.904] (ha),
XIMP=[0.90], TIMP=[0.90], DWF=[0.0] (cms), LOSS=[2],
SCS curve number CN=[70.0],
Pervious surfaces: IAPER=[5] (mm), SLPP=[2.0] (%),
LGP=[40.0] (m), MNP=[0.25], SCP=[0.0] (mi)
Impervious surfaces: IAIMP=[2] (mm), SLFI=[1.0] (%),
LGI=[30] (m), MNI=[0.013], SCI=[0.0] (min)
RAINFALL=[ , , , ] (mm/hr) , END=-1

```

```

*# BUILDING AREAS WITH CONTROLLED FLOW ROOF DRAINS
CALIB STANDHYD
ID=[2], NHYD=["002"], DT=[1] (min), AREA=[6.0108] (ha),
XIMP=[0.99], TIMP=[0.99], DWF=[0.0] (cms), LOSS=[2],
SCS curve number CN=[70.0],
Pervious surfaces: IAPER=[5] (mm), SLPP=[2.0] (%),
LGP=[40.0] (m), MNP=[0.25], SCP=[0.0] (mi)
Impervious surfaces: IAIMP=[2] (mm), SLFI=[1.0] (%),
LGI=[30] (m), MNI=[0.013], SCI=[0.0] (min)
RAINFALL=[ , , , ] (mm/hr) , END=-1

```

```

* CONTROLLED FLOW ROOF DRAINS - BLDG A & B
ROUTE RESERVOIR
IDout= 3 , NHYD= 200 , IDin= 2 ,
RDT=[1] (min),
TABLE of ( OUTFLOW-STORAGE ) values
(cms) - (ha-m)
0 0
0.1401 0.20579
0.1861 0.35601
0.2322 0.50622
2.0000 0.50700
-1 -1
IDovf=[7], NHYDovf=[1007]

```

```

ADD HYD
IDsum=4, NHYD=503, IDs to add=[1+3+7]
*#*****
*# STORMWATER MANAGEMENT
*# BELOW GROUND STORAGE SYSTEM
*# BOTTOM ELEV: 90.0m ; TOP ELEV 92.06
*# EROS/EXT ELEV 91.10, EROS VOL 2,581m3

```

```

*#*****
*# ORIFICE 1: ELEV 89.15, 63mm ORIFICE
*# ORIFICE 2: ELEV 91.80, 260mm DIA.
*# STORMTECH CHAMBERS MC-4500 - 1,837m3
*# SURFACE DRY POND AREA - 3,405m3
*# SURFACE STORAGE - 0.25m DEEP - 820m3
*# TOTAL VOLUME: 5,077 m3
*#*****

```

```

ROUTE RESERVOIR
IDout= 5 , NHYD= 201 , IDin= 4 ,
RDT=[1] (min),
TABLE of ( OUTFLOW-STORAGE ) values
(cms) - (ha-m)
0.0000 0.0000
0.0083 0.0070
0.0088 0.0143
0.0096 0.0416
0.0104 0.0715
0.0111 0.1023
0.0117 0.1309
0.0120 0.1468
0.0124 0.1626
0.0130 0.1937
0.0135 0.2233
0.0138 0.2366
0.0141 0.2496
0.0143 0.2629
0.0538 0.2764
0.0682 0.2841
0.1277 0.3242
0.1703 0.3792
0.2037 0.4455
0.2185 0.5653
IDovf=[ , , , ] , NHYDovf=[ ]

```

```

*# PRINT HYD
ID = 5 # OF PCYCLES=1
*# MODEL SIMULATION OF THE THREE STAGES OF PUMPING
*# PI=14 l/s, P1+P2=76l/s, P1+P2+P3=221 l/s
ROUTE RESERVOIR
IDout= 6 , NHYD= 200 , IDin= 4 ,
RDT=[1] (min),
TABLE of ( OUTFLOW-STORAGE ) values
(cms) - (ha-m)
0 0
0.012 0.0010
0.014 0.2496
0.075 0.2600
0.076 0.4277
0.211 0.4287
0.221 0.5653
IDovf=[ , , , ] , NHYDovf=[ ]

```

```

*#*****
START
TZERO=[0.0], METOUT=[2], NSTORM=[2], NRUN= [002]
"CHIC2YR.STM"
START
TZERO=[0.0], METOUT=[2], NSTORM=[2], NRUN= [003]
"CHIC5YR.STM"
START
TZERO=[0.0], METOUT=[2], NSTORM=[2], NRUN= [004]
"CHIC10YR.STM"

```

START TZERO=[0.0], METOUT=[2], NSTORM=[1], NRUN= [005]
"CHIC25YR.STM"
START TZERO=[0.0], METOUT=[2], NSTORM=[1], NRUN= [006]
"CHIC50YR.STM"
START TZERO=[0.0], METOUT=[2], NSTORM=[1], NRUN= [007]
"CH100YR.STM"
START TZERO=[0.0], METOUT=[2], NSTORM=[1], NRUN= [008]
"2Y24HS.STM"
START TZERO=[0.0], METOUT=[2], NSTORM=[1], NRUN= [009]
"5Y24HS.STM"
START TZERO=[0.0], METOUT=[2], NSTORM=[1], NRUN= [010]
"10Y24HS.STM"
START TZERO=[0.0], METOUT=[2], NSTORM=[1], NRUN= [011]
"25Y24HS.STM"
START TZERO=[0.0], METOUT=[2], NSTORM=[1], NRUN= [012]
"50Y24HS.STM"
START TZERO=[0.0], METOUT=[2], NSTORM=[1], NRUN= [013]
"100Y24HS.STM"

FINISH

```

=====
SSSSS W W M M H H Y Y M M O O O 999 999
S W W M M H H Y Y M M M O O 9 9 9 9
SSSSS W W M M H H H H Y Y M M O O # 9 9 9 9 Ver. 4.02
S W W M M H H Y Y M M O O 9999 9999 July 1999
SSSSS W W M M H H Y Y M M O O 9 9 9 9
=====
StormWater Management Hydrologic Model
999 999 # 3813174
=====

```

```

| START | Project dir.: C:\PROGRA-1\SWMHYMO\Projects\2256\
-----| Rainfall dir.: C:\PROGRA-1\SWMHYMO\Projects\2256\
TZERO = .00 hrs on 0
METOUT= 2 (output = METRIC)
NRUN = 001
NSTORM= 1
# 1=CHIC25MM.STM
001:0002-----
*

```

File name: C:\PROGRA-1\SWMHYMO\Projects\2256\CHIC25

Comments: *BLOOR ST STAT DATA 10 MIN DISCRITIZATIO

TIME	RAIN	TIME	RAIN	TIME	RAIN	TIME	RAIN
hrs	mm/hr	hrs	mm/hr	hrs	mm/hr	hrs	mm/hr
.08	1.624	1.08	12.284	2.08	3.786	3.08	1.940
.17	1.624	1.17	12.284	2.17	3.786	3.17	1.940
.25	1.853	1.25	58.772	2.25	3.233	3.25	1.803
.33	1.853	1.33	58.772	2.33	3.233	3.33	1.803
.42	2.170	1.42	16.185	2.42	2.838	3.42	1.688
.50	2.170	1.50	16.185	2.50	2.838	3.50	1.688
.58	2.651	1.58	8.549	2.58	2.529	3.58	1.588
.67	2.651	1.67	8.549	2.67	2.529	3.67	1.588
.75	3.470	1.75	5.927	2.75	2.292	3.75	1.501
.83	3.470	1.83	5.927	2.83	2.292	3.83	1.501
.92	5.201	1.92	4.598	2.92	2.098	3.92	1.422
1.00	5.201	2.00	4.598	3.00	2.098	4.00	1.422

```

001:0003-----
*****
**SITE 772 WINSTON CHURCHILL*
*****
*

```

* PAVED AREAS AND LANDSCAPED AREAS

CALIB STANDHYD	Area	(ha)=	5.90
01:001	DT= 1.00	Total Imp(%)=	90.00 Dir. Conn.(%)= 90.00
Surface Area	(ha) =	5.31	PERVIOUS (i)
Dep. Storage	(mm) =	2.00	5.00
Average Slope	(%) =	1.00	2.00
Length	(m) =	30.00	40.00
Mannings n	=	.013	.250
Max. eff. Inten. (mm/hr) =		58.77	3.13
over (min) =		2.00	30.00
Storage Coeff. (min) =		1.53 (ii)	29.74 (ii)
Unit Hyd. Tpeak (min) =		2.00	30.00
Unit Hyd. peak (cms) =		.66	.04
PEAK FLOW (cms) =		.87	.00
TIME TO PEAK (hrs) =		1.33	1.92
RUNOFF VOLUME (mm) =		23.00	3.10
TOTAL RAINFALL (mm) =		25.00	25.000
RUNOFF COEFFICIENT =		.92	.12
			TOTALS
			.866 (iii)
			1.333
			21.010
			25.000
			.840

(i) CN PROCEDURE SELECTED FOR PERVIOUS LOSSES:

```

*****
***** SWHMYMO-99 Ver/4.02 *****
***** A single event and continuous hydrologic simulation model *****
***** based on the principles of HYMO and its successors *****
***** OTHYMO-83 and OTHYMO-89. *****
***** Distributed by: J.F. Sabourin and Associates Inc. *****
***** Ottawa, Ontario: (613) 727-5199 *****
***** Gatineau, Quebec: (819) 243-6858 *****
***** E-Mail: swmhymo@jfsa.com *****
*****
+++++ Licensed user: A.M. Candaras Associates Inc. +++++
+++++ Woodbridge SERIAL#: 3813174 +++++
*****
***** +++++ PROGRAM ARRAY DIMENSIONS +++++ *****
***** Maximum value for ID numbers : 10 *****
***** Max. number of rainfall points: 15000 *****
***** Max. number of flow points : 15000 *****
*****
*****
***** D E T A I L E D O U T P U T *****
*****
DATE: 2022-12-15 TIME: 15:41:55 RUN COUNTER: 000529
* Input filename: C:\PROGRA-1\SWMHYMO\Projects\2256\2256PstC.out *
* Output filename: C:\PROGRA-1\SWMHYMO\Projects\2256\2256PstC.out *
* Summary filename: C:\PROGRA-1\SWMHYMO\Projects\2256\2256PstC.sum *
* User comments: *
* 1: *
* 2: *
* 3: *
*****

```

```

001:0001-----
# Project Name: 772 Winston Churchill Blvd., Oakville
# Project Number: 2256
# Date : DECEMBER 2022
# Modeller : FP
# Company : a.m. candaras associates inc.
# License # : 3813174
# Revision : C
#

```

- CN* = 70.0 Ia = Dep. Storage (Above)
- (ii) TIME STEP (DT) SHOULD BE SMALLER OR EQUAL THAN THE STORAGE COEFFICIENT.
- (iii) PEAK FLOW DOES NOT INCLUDE BASEFLOW IF ANY.

001:0004

* BUILDING AREAS WITH CONTROLLED FLOW ROOF DRAINS

CALIB STANDHYD Area (ha) = 6.01 Dir. Conn. (%) = 99.00
 02:002 DT= 1.00 Total Imp (%) = 99.00

IMPERVIOUS PERVIOUS (i)

Surface Area (ha) = 5.95 Pervious .06
 Dep. Storage (mm) = 2.00 5.00
 Average Slope (%) = 1.00 2.00
 Length (m) = 30.00 40.00
 Mannings n = .013 .250

Max. eff. Inten. (mm/hr) = 58.77 3.13
 over (min) = 2.00 30.00
 Storage Coeff. (min) = 1.53 (ii) 29.74 (ii)
 Unit Hyd. Ipeak (min) = 2.00 30.00
 Unit Hyd. peak (cms) = .66 .04

PEAK FLOW (cms) = .97 .970 (iii)

TIME TO PEAK (hrs) = 1.33 1.92 1.333
 RUNOFF VOLUME (mm) = 23.00 3.10 22.801
 TOTAL RAINFALL (mm) = 25.00 25.00 25.000
 RUNOFF COEFFICIENT = .92 .912

TOTALS
 .970 (iii)
 1.333
 22.801
 25.000
 .912

001:0005

* CONTROLLED FLOW ROOF DRAINS - BLDG A & B

ROUTE RESERVOIR Requested routing time step = 1.0 min.

IN>02: (002)
 OUT<03: (000200)

OUTFLOW (cms)	STORAGE (ha.m.)	OUTFLOW (cms)	STORAGE (ha.m.)
.000	.0000E+00	.232	.5062E+00
.140	.2058E+00	2.000	.5070E+00
.186	.3560E+00	.000	.0000E+00

ROUTING RESULTS
 AREA (ha) QPEAK (cms) TPEAK (hrs) R.V. (mm)
 INFLOW >02: (002) 6.01 .970 1.333 22.801
 OUTFLOW<03: (000200) 6.01 .064 2.083 22.801
 OVERFLOW<07: (001007) .00 .000 .000 .000

TOTAL NUMBER OF SIMULATED OVERFLOWS = 0
 CUMULATIVE TIME OF OVERFLOWS (hours) = .00
 PERCENTAGE OF TIME OVERFLOWING (%) = .00

- PEAK FLOW REDUCTION [Qout/Qin] (%) = 6.572
- TIME SHIFT OF PEAK FLOW (min) = 45.00
- MAXIMUM STORAGE USED (ha.m.) = .9361E-01

001:0006

ADD HYD (000503) ID: NHYD AREA (ha) QPEAK (cms) TPEAK (hrs) R.V. (mm) DWF (cms)
 ID1 01:001 5.90 .866 1.33 21.01 .000
 +ID2 03:000200 6.01 .064 2.08 22.80 .000
 +ID3 07:001007 .00 .000 .00 .00 .000 **DRY**
 SUM 04:000503 11.91 .908 1.33 21.91 .000

NOTE: PEAK FLOWS DO NOT INCLUDE BASEFLOWS IF ANY.

001:0007

 *STORMWATER MANAGEMENT
 *BELOW GROUND STORAGE SYSTEM
 *BOTTOM ELEV: 90.0m ; TOP ELEV 92.06
 *EROS/EXT ELEV 91.10, EROS VOL 2,581m3
 *ORIFICE 1: ELEV 89.15, 63mm ORIFICE
 *ORIFICE 2: ELEV 91.80, 260mm DIA.
 *STORMTECH CHAMBERS MC-4500 - 1,837m3
 *SURFACE DRY POND AREA - 3,405m3
 *SURFACE STORAGE - 0.25m DEEP - 820m3
 *TOTAL VOLUME: 5,077 m3

ROUTE RESERVOIR Requested routing time step = 1.0 min.

IN>04: (000503)
 OUT<05: (000201)

OUTFLOW (cms)	STORAGE (ha.m.)	OUTFLOW (cms)	STORAGE (ha.m.)
.000	.0000E+00	.014	.2233E+00
.008	.7000E-02	.014	.2366E+00
.009	.1430E-01	.014	.2496E+00
.010	.4160E-01	.014	.2629E+00
.010	.7150E-01	.054	.2764E+00
.011	.1023E+00	.068	.2841E+00
.012	.1309E+00	.128	.3242E+00
.012	.1468E+00	.170	.3792E+00
.012	.1626E+00	.204	.4455E+00
.013	.1937E+00	.219	.5653E+00

ROUTING RESULTS
 AREA (ha) QPEAK (cms) TPEAK (hrs) R.V. (mm)
 INFLOW >04: (000503) 11.91 .908 1.333 21.914
 OUTFLOW<05: (000201) 11.91 .013 9.700 21.914

PEAK FLOW REDUCTION [Qout/Qin] (%) = 1.449
 TIME SHIFT OF PEAK FLOW (min) = 502.00
 MAXIMUM STORAGE USED (ha.m.) = .2028E+00

001:0008-----
*PRINT HYD ID = 5 # OF PCYCLES=1
* MODEL SIMULATION OF THE THREE STAGES OF PUMPING
* P1=14 l/s, P1+P2=76l/s, P1+P2+P3=221 l/s
Requested routing time step = 1.0 min.
===== OUTFLOW STORAGE TABLE =====
OUTFLOW STORAGE OUTFLOW STORAGE
(cms) (ha.m.) (cms) (ha.m.)
.000 .000E+00 .076 .4277E+00
.012 .1000E-02 .211 .4287E+00
.014 .2496E+00 .221 .5653E+00
.075 .2600E+00 .000 .0000E+00

ROUTING RESULTS AREA QPEAK TPEAK R.V.
(ha) (cms) (hrs) (mm)
INFLOW >04: (000503) 11.91 .908 1.333 21.914
OUTFLOW <06: (000200) 11.91 .014 9.567 21.914

PEAK FLOW REDUCTION [Qout/Qin] (%) = 1.498
TIME SHIFT OF PEAK FLOW (min) = 494.00
MAXIMUM STORAGE USED (ha.m.) = .1996E+00

** END OF RUN : 1

001:0009-----
Project dir.: C:\PROGRA-1\SWMHYMO\Projects\2256\
Rainfall dir.: C:\PROGRA-1\SWMHYMO\Projects\2256\
TZERO = .00 hrs on 0
METOUT= 2 (output = METRIC)
NRUN = 002
NSTORM= 1
1=CHIC2YR.STM

002:0002-----
Project Name: 772 Winston Churchill Blvd., Oakville
Project Number: 2256
Date : DECEMBER 2022
Modeler : FP
Company : a.m. candaras associates inc.
License # : 3813174
Revision : C

002:0002-----
* BUILDING AREAS WITH CONTROLLED FLOW ROOF DRAINS
CALIB STANDHYD Area (ha) = 6.01
02:002 DT= 1.00 Total Imp (%) = 99.00 Dir. Conn. (%) = 99.00
*

002:0003-----
* SITE 772 WINSTON CHURCHILL*

* PAVED AREAS AND LANDSCAPED AREAS
CALIB STANDHYD Area (ha) = 5.90
01:001 DT= 1.00 Total Imp (%) = 90.00 Dir. Conn. (%) = 90.00

IMPERVIOUS PERVIOUS (i)
Surface Area (ha) = 5.31 .59
Dep. Storage (mm) = 2.00 5.00
Average Slope (%) = 1.00 2.00
Length (m) = 30.00 40.00
Mannings n = .013 .250
Max.eff.Inten. (mm/hr) = 81.81 8.53
over (min) = 1.00 20.00
Storage Coeff. (min) = 1.34 (ii) 20.24 (ii)
Unit Hyd. Tpeak (min) = 1.00 20.00
Unit Hyd. peak (cms) = .89 .06
PEAK FLOW (cms) = 1.21 .01
TIME TO PEAK (hrs) = 1.33 1.65
RUNOFF VOLUME (mm) = 32.80 6.40
TOTAL RAINFALL (mm) = 34.80 34.80
RUNOFF COEFFICIENT = .94 .18
TOTALS
1.208 (iii)
1.333
30.161
34.800
.867

(i) CN PROCEDURE SELECTED FOR PERVIOUS LOSSES:
CN* = 70.0 Ia = Dep. Storage (Above)
(ii) TIME STEP (DT) SHOULD BE SMALLER OR EQUAL
THAN THE STORAGE COEFFICIENT.
(iii) PEAK FLOW DOES NOT INCLUDE BASEFLOW IF ANY.
002:0004-----
*

001:0008-----
*PRINT HYD ID = 5 # OF PCYCLES=1
* MODEL SIMULATION OF THE THREE STAGES OF PUMPING
* P1=14 l/s, P1+P2=76l/s, P1+P2+P3=221 l/s
Requested routing time step = 1.0 min.
===== OUTFLOW STORAGE TABLE =====
OUTFLOW STORAGE OUTFLOW STORAGE
(cms) (ha.m.) (cms) (ha.m.)
.000 .000E+00 .076 .4277E+00
.012 .1000E-02 .211 .4287E+00
.014 .2496E+00 .221 .5653E+00
.075 .2600E+00 .000 .0000E+00

ROUTING RESULTS AREA QPEAK TPEAK R.V.
(ha) (cms) (hrs) (mm)
INFLOW >04: (000503) 11.91 .908 1.333 21.914
OUTFLOW <06: (000200) 11.91 .014 9.567 21.914

PEAK FLOW REDUCTION [Qout/Qin] (%) = 1.498
TIME SHIFT OF PEAK FLOW (min) = 494.00
MAXIMUM STORAGE USED (ha.m.) = .1996E+00

** END OF RUN : 1

001:0009-----
Project dir.: C:\PROGRA-1\SWMHYMO\Projects\2256\
Rainfall dir.: C:\PROGRA-1\SWMHYMO\Projects\2256\
TZERO = .00 hrs on 0
METOUT= 2 (output = METRIC)
NRUN = 002
NSTORM= 1
1=CHIC2YR.STM

002:0002-----
Project Name: 772 Winston Churchill Blvd., Oakville
Project Number: 2256
Date : DECEMBER 2022
Modeler : FP
Company : a.m. candaras associates inc.
License # : 3813174
Revision : C

002:0002-----
* BUILDING AREAS WITH CONTROLLED FLOW ROOF DRAINS
CALIB STANDHYD Area (ha) = 6.01
02:002 DT= 1.00 Total Imp (%) = 99.00 Dir. Conn. (%) = 99.00
*

002:0003-----
* SITE 772 WINSTON CHURCHILL*

* PAVED AREAS AND LANDSCAPED AREAS
CALIB STANDHYD Area (ha) = 5.90
01:001 DT= 1.00 Total Imp (%) = 90.00 Dir. Conn. (%) = 90.00

IMPERVIOUS PERVIOUS (i)
Surface Area (ha) = 5.31 .59
Dep. Storage (mm) = 2.00 5.00
Average Slope (%) = 1.00 2.00
Length (m) = 30.00 40.00
Mannings n = .013 .250
Max.eff.Inten. (mm/hr) = 81.81 8.53
over (min) = 1.00 20.00
Storage Coeff. (min) = 1.34 (ii) 20.24 (ii)
Unit Hyd. Tpeak (min) = 1.00 20.00
Unit Hyd. peak (cms) = .89 .06
PEAK FLOW (cms) = 1.21 .01
TIME TO PEAK (hrs) = 1.33 1.65
RUNOFF VOLUME (mm) = 32.80 6.40
TOTAL RAINFALL (mm) = 34.80 34.80
RUNOFF COEFFICIENT = .94 .18
TOTALS
1.208 (iii)
1.333
30.161
34.800
.867

(i) CN PROCEDURE SELECTED FOR PERVIOUS LOSSES:
CN* = 70.0 Ia = Dep. Storage (Above)
(ii) TIME STEP (DT) SHOULD BE SMALLER OR EQUAL
THAN THE STORAGE COEFFICIENT.
(iii) PEAK FLOW DOES NOT INCLUDE BASEFLOW IF ANY.
002:0004-----
*

IMPERVIOUS PERVIOUS (i)
 Surface Area (ha) = 5.95
 Dep. Storage (mm) = 2.00
 Average Slope (%) = 1.00
 Length (m) = 30.00
 Mannings n = .013

Max. eff. Inten. (mm/hr) = 81.81
 over (min) = 1.00
 Storage Coeff. (min) = 1.34 (ii)
 Unit Hyd. Tpeak (min) = 1.00
 Unit Hyd. peak (cms) = .89
 PEAK FLOW (cms) = 1.35
 TIME TO PEAK (hrs) = 1.33
 RUNOFF VOLUME (mm) = 32.80
 TOTAL RAINFALL (mm) = 34.80
 RUNOFF COEFFICIENT = .94

- (i) CN PROCEDURE SELECTED FOR PERVIOUS LOSSES:
 CN* = 70.0 Ia = Dep. Storage (Above)
- (ii) TIME STEP (DT) SHOULD BE SMALLER OR EQUAL THAN THE STORAGE COEFFICIENT.
- (iii) PEAK FLOW DOES NOT INCLUDE BASEFLOW IF ANY.

TOTALS
 1.352 (iii)
 1.333
 32.536
 34.800
 .935

002:0005-----
 * CONTROLLED FLOW ROOF DRAINS - BLDG A & B

ROUTE RESERVOIR IN>02: (002) Requested routing time step = 1.0 min.

OUTFLOW (cms)	STORAGE (ha.m.)	OUTFLOW (cms)	STORAGE (ha.m.)
.000	.0000E+00	.232	.5062E+00
.140	.2058E+00	2.000	.5070E+00
.186	.3560E+00	.000	.0000E+00

ROUTING RESULTS
 INFLOW >02: (002) AREA QPEAK TPEAK R.V.
 (000200) 6.01 1.352 1.333 32.536
 OUTFLOW <03: (000200) 6.01 .091 2.033 32.536
 OVERFLOW <07: (001007) .00 .000 .000 .000

TOTAL NUMBER OF SIMULATED OVERFLOWS = 0
 CUMULATIVE TIME OF OVERFLOWS (hours) = .00
 PERCENTAGE OF TIME OVERFLOWING (%) = .00

PEAK FLOW REDUCTION [Qout/Qin] (%) = 6.739
 TIME SHIFT OF PEAK FLOW (min) = 42.00
 MAXIMUM STORAGE USED (ha.m.) = .1338E+00

ADD HYD (000503)	ID:	NHYD	AREA (ha)	QPEAK (cms)	TPEAK (hrs)	R.V. (mm)	DWF (cms)
ID1 01:001			5.90	1.208	1.33	30.16	.000
+ID2 03:000200			6.01	.091	2.03	32.54	.000

+ID3 07:001007 .00 .000 .00 .00 .000 **DRY**
 SUM 04:000503 11.91 1.273 1.33 31.36 .000

NOTE: PEAK FLOWS DO NOT INCLUDE BASEFLOWS IF ANY.

002:0007-----
 *STORMWATER MANAGEMENT
 *BELOW GROUND STORAGE SYSTEM
 *BOTTOM ELEV:90.0m ; TOP ELEV 92.06
 *EROS/EXT ELEV 91.10, EROS VOL 2,581m3
 *ORIFICE 1: ELEV 89.15, 63mm ORIFICE
 *ORIFICE 2: ELEV 91.80, 260mm DIA.
 *STORMTECH CHAMBERS MC-4500 - 1,837m3
 *SURFACE DRY POND AREA - 3,405m3
 *SURFACE STORAGE - 0.25m DEEP - 820m3
 *TOTAL VOLUME: 5,077 m3

Requested routing time step = 1.0 min.

ROUTE RESERVOIR IN>04: (000503)	OUT<05: (000201)	OUTFLOW (cms)	STORAGE (ha.m.)	OUTFLOW (cms)	STORAGE (ha.m.)
		.000	.0000E+00	.014	.2233E+00
		.008	.7000E-02	.014	.2366E+00
		.009	.1430E-01	.014	.2496E+00
		.010	.4160E-01	.014	.2629E+00
		.010	.7150E-01	.054	.2764E+00
		.011	.1023E+00	.068	.2841E+00
		.012	.1309E+00	.128	.3242E+00
		.012	.1468E+00	.170	.3792E+00
		.012	.1626E+00	.204	.4455E+00
		.013	.1937E+00	.219	.5653E+00

ROUTING RESULTS
 INFLOW >04: (000503) AREA QPEAK TPEAK R.V.
 (000201) 11.91 1.273 1.333 31.359
 OUTFLOW <05: (000201) 11.91 .043 6.283 31.359

PEAK FLOW REDUCTION [Qout/Qin] (%) = 3.391
 TIME SHIFT OF PEAK FLOW (min) = 297.00
 MAXIMUM STORAGE USED (ha.m.) = .2728E+00

002:0008-----
 *PRINT HYD ID = 5 # OF PCYCLES=1

* MODEL SIMULATION OF THE THREE STAGES OF PUMPING
 * P1=14 l/s, P1+P2=76l/s, P1+P2+P3=221 l/s

Requested routing time step = 1.0 min.

ROUTE RESERVOIR IN>04: (000503)	OUT<06: (000200)	OUTFLOW (cms)	STORAGE (ha.m.)	OUTFLOW (cms)	STORAGE (ha.m.)
		.000	.0000E+00	.076	.4277E+00
		.012	.1000E-02	.211	.4287E+00
		.014	.2496E+00	.221	.5653E+00

ROUTING RESULTS
 INFLOW >04: (000503) 11.91
 OUTFLOW<06: (000200) 11.91

PEAK FLOW REDUCTION [Qout/Qin] (%) = 4.464
 TIME SHIFT OF PEAK FLOW (min) = 230.00
 MAXIMUM STORAGE USED (ha.m.) = .2569E+00

002:0009

002:0002
 ** END OF RUN : 2

START | Project dir.: C:\PROGRA-1\SWHMYM\Projects\2256\
 Rainfall dir.: C:\PROGRA-1\SWHMYM\Projects\2256\
 TZERO = .00 hrs on 0
 METOUT= 2 (output = METRIC)
 NRUN = 003
 NSTORM= 1
 # 1=CHIC5YR.STM

003:0002

 ** Project Name: 772 Winston Churchill Blvd., Oakville
 ** Project Number: 2256
 ** Date : DECEMBER 2022
 ** Modeller : FP
 ** Company : a.m. candaras associates inc.
 ** License # : 3813174
 ** Revision : C

003:0002
 *

READ STORM
 Ptotal= 46.25 mm

TIME	RAIN	TIME	RAIN	TIME	RAIN	TIME	RAIN
hrs	mm/hr	hrs	mm/hr	hrs	mm/hr	hrs	mm/hr
.08	2.820	1.08	22.680	2.08	6.740	3.08	3.400
.17	2.820	1.17	22.680	2.17	6.740	3.17	3.400
.25	3.240	1.25	113.160	2.25	5.730	3.25	3.150
.33	3.240	1.33	113.160	2.33	5.730	3.33	3.150
.42	3.810	1.42	30.090	2.42	5.010	3.42	2.950
.50	3.810	1.50	30.090	2.50	5.010	3.50	2.950
.58	4.680	1.58	15.580	2.58	4.460	3.58	2.770
.67	4.680	1.67	15.580	2.67	4.460	3.67	2.770

.75 6.160 | 1.75 10.690 | 2.75 4.030 | 3.75 2.610
 .83 6.160 | 1.83 10.690 | 2.83 4.030 | 3.83 2.610
 .92 9.350 | 1.92 8.230 | 2.92 3.680 | 3.92 2.480
 1.00 9.350 | 2.00 8.230 | 3.00 3.680 | 4.00 2.480

003:0003

SITE 772 WINSTON CHURCHILL

* PAVED AREAS AND LANDSCAPED AREAS

CALIB STANDHYD | Area (ha) = 5.90
 01:001 | DT= 1.00 | Total Imp(%) = 90.00 | Dir. Conn. (%) = 90.00

IMPERVIOUS PERVIOUS (i)
 Surface Area (ha) = 5.31 | .59
 Dep. Storage (mm) = 2.00 | 5.00
 Average Slope (%) = 1.00 | 2.00
 Length (m) = 30.00 | 40.00
 Mannings n = .013 | .250

Max.eff.Inten.(mm/hr) = 113.16 | 18.45
 over (min) = 1.00 | 15.00
 Storage Coeff. (min) = 1.18 (ii) | 15.06 (ii)
 Unit Hyd. Tpeak (min) = 1.00 | 15.00
 Unit Hyd. peak (cms) = .97 | .08

PEAK FLOW (cms) = 1.67 | .02
 TIME TO PEAK (hrs) = 1.33 | 1.57
 RUNOFF VOLUME (mm) = 44.25 | 11.34
 TOTAL RAINFALL (mm) = 46.25 | 46.250
 RUNOFF COEFFICIENT = .96 | .25
 TOTALS
 1.675 (iii)
 1.333
 40.959
 46.250
 .886

(i) CN PROCEDURE SELECTED FOR PERVIOUS LOSSES:
 CN* = 70.0 Ia = Dep. Storage (Above)
 (ii) TIME STEP (DT) SHOULD BE SMALLER OR EQUAL
 THAN THE STORAGE COEFFICIENT.
 (iii) PEAK FLOW DOES NOT INCLUDE BASEFLOW IF ANY.

003:0004
 *

* BUILDING AREAS WITH CONTROLLED FLOW ROOF DRAINS

CALIB STANDHYD | Area (ha) = 6.01
 02:002 | DT= 1.00 | Total Imp(%) = 99.00 | Dir. Conn. (%) = 99.00

IMPERVIOUS PERVIOUS (i)
 Surface Area (ha) = 5.95 | .06
 Dep. Storage (mm) = 2.00 | 5.00
 Average Slope (%) = 1.00 | 2.00
 Length (m) = 30.00 | 40.00
 Mannings n = .013 | .250

Max.eff.Inten.(mm/hr) = 113.16 | 18.45
 over (min) = 1.00 | 15.00
 Storage Coeff. (min) = 1.18 (ii) | 15.06 (ii)
 Unit Hyd. Tpeak (min) = 1.00 | 15.00

Unit Hyd. peak (cms) = .97 .08
 PEAK FLOW (cms) = 1.87 .00
 TIME TO PEAK (hrs) = 1.33 1.57
 RUNOFF VOLUME (mm) = 44.25 11.34
 TOTAL RAINFALL (mm) = 46.25 46.250
 RUNOFF COEFFICIENT = .96 .25

- (i) CN PROCEDURE SELECTED FOR PERVIOUS LOSSES:
 CN* = 70.0 Ia = Dep. Storage (Above)
- (ii) TIME STEP (DT) SHOULD BE SMALLER OR EQUAL THAN THE STORAGE COEFFICIENT.
- (iii) PEAK FLOW DOES NOT INCLUDE BASEFLOW IF ANY.

003:0005-----
 * CONTROLLED FLOW ROOF DRAINS - BLDG A & B

ROUTE RESERVOIR
 IN>02: (002)
 OUT<03: (000200) -----
 Requested routing time step = 1.0 min.
 ===== OUTFLOW STORAGE TABLE =====
 OUTFLOW STORAGE OUTFLOW STORAGE
 (cms) (ha.m.) (cms) (ha.m.)
 .000 .0000E+00 .232 .5062E+00
 .140 .2058E+00 2.000 .5070E+00
 .186 .3560E+00 .000 .0000E+00

ROUTING RESULTS AREA QPEAK TPEAK R.V.
 (ha) (cms) (hrs) (mm)
 INFLOW >02: (002) 6.01 1.871 1.333 43.921
 OUTFLOW<03: (000200) 6.01 .124 2.017 43.921
 OVERFLOW<07: (001007) .00 .000 .000 .000

TOTAL NUMBER OF SIMULATED OVERFLOWS = 0
 CUMULATIVE TIME OF OVERFLOWS (hours) = .00
 PERCENTAGE OF TIME OVERFLOWING (%) = .00

PEAK FLOW REDUCTION [Qout/Qin] (%) = 6.654
 TIME SHIFT OF PEAK FLOW (min) = 41.00
 MAXIMUM STORAGE USED (ha.m.) = .1828E+00

003:0006-----
 | ADD HYD (000503) | ID: NHYD AREA QPEAK TPEAK R.V. DWF
 (cms) (ha) (cms) (hrs) (mm) (cms)
 ID1 01:001 5.90 1.675 1.33 40.96 .000
 +ID2 03:000200 6.01 .124 2.02 43.92 .000
 +ID3 07:001007 .00 .000 .00 .00 .000 **DRY**
 =====
 SUM 04:000503 11.91 1.766 1.33 42.45 .000

NOTE: PEAK FLOWS DO NOT INCLUDE BASEFLOWS IF ANY.

003:0007-----

 *STORMWATER MANAGEMENT
 *BELOW GROUND STORAGE SYSTEM

*BOTTOM ELEV:90.0m ; TOP ELEV 92.06
 *EROS/EXT ELEV 91.10, EROS VOL 2,581m3
 *ORIFICE 1: ELEV 89.15, 63mm ORIFICE
 *ORIFICE 2: ELEV 91.80, 260mm DIA.
 *STORMTECH CHAMBERS MC-4500 - 1,837m3
 *SURFACE DRY POND AREA - 3,405m3
 *SURFACE STORAGE - 0.25m DEEP - 820m3
 *TOTAL VOLUME: 5,077 m3

Requested routing time step = 1.0 min.

ROUTE RESERVOIR
 IN>04: (000503)
 OUT<05: (000201) -----
 ===== OUTFLOW STORAGE TABLE =====
 OUTFLOW STORAGE OUTFLOW STORAGE
 (cms) (ha.m.) (cms) (ha.m.)
 .000 .0000E+00 .014 .2233E+00
 .008 .7000E-02 .014 .2366E+00
 .009 .1430E-01 .014 .2496E+00
 .010 .4160E-01 .014 .2629E+00
 .010 .7150E-01 .054 .2764E+00
 .011 .1023E+00 .068 .2841E+00
 .012 .1309E+00 .128 .3242E+00
 .012 .1468E+00 .170 .3792E+00
 .012 .1626E+00 .204 .4455E+00
 .013 .1937E+00 .219 .5653E+00

ROUTING RESULTS AREA QPEAK TPEAK R.V.
 (ha) (cms) (hrs) (mm)
 INFLOW >04: (000503) 11.91 1.766 1.333 42.453
 OUTFLOW<05: (000201) 11.91 .105 4.050 42.453

PEAK FLOW REDUCTION [Qout/Qin] (%) = 5.927
 TIME SHIFT OF PEAK FLOW (min) = 163.00
 MAXIMUM STORAGE USED (ha.m.) = .3087E+00

003:0008-----
 *PRINT HYD ID = 5 # OF PCYCLES=1
 * MODEL SIMULATION OF THE THREE STAGES OF PUMPING
 * P1=14 l/s, P1+P2=76l/s, P1+P2+P3=221 l/s

Requested routing time step = 1.0 min.

ROUTE RESERVOIR
 IN>04: (000503)
 OUT<06: (000200) -----
 ===== OUTFLOW STORAGE TABLE =====
 OUTFLOW STORAGE OUTFLOW STORAGE
 (cms) (ha.m.) (cms) (ha.m.)
 .000 .0000E+00 .076 .4277E+00
 .012 .1000E-02 .211 .4287E+00
 .014 .2496E+00 .221 .5653E+00
 .075 .2600E+00 .000 .0000E+00

ROUTING RESULTS AREA QPEAK TPEAK R.V.
 (ha) (cms) (hrs) (mm)
 INFLOW >04: (000503) 11.91 1.766 1.333 42.453
 OUTFLOW<06: (000200) 11.91 .075 5.200 42.453

PEAK FLOW REDUCTION [Qout/Qin] (%) = 4.264
 TIME SHIFT OF PEAK FLOW (min) = 232.00
 MAXIMUM STORAGE USED (ha.m.) = .3119E+00

003:0009-----

003:0002-----
003:0002-----
** END OF RUN : 3

| START | Project dir.: C:\PROGRA~1\SWHMYM\Projects\2256\
| | Rainfall dir.: C:\PROGRA~1\SWHMYM\Projects\2256\
| | IZERO = .00 hrs on
| | METOUT= 2 (output = METRIC)
| | NRUN = 004
| | NSTORM= 1
| | # 1=CHIC10YR.STM

004:0002-----

Project Name: 772 Winston Churchill Blvd., Oakville
Project Number: 2256
Date : DECEMBER 2022
Modeller : FP
Company : a.m. candaras associates inc.
License # : 3813174
Revision : C

004:0002-----
*
| READ STORM | File name: C:\PROGRA~1\SWHMYM\Projects\2256\CHIC10
| Ptotal= 54.14 mm | Comments: *BLOOR ST STAT DATA 10 MIN DISCRITIZATIO

TIME	RAIN	TIME	RAIN	TIME	RAIN	TIME	RAIN	TIME	RAIN
hrs	mm/hr	hrs	mm/hr	hrs	mm/hr	hrs	mm/hr	hrs	mm/hr
.08	3.410	1.08	25.220	2.08	7.880	3.08	4.080	4.08	4.080
.17	3.410	1.17	25.220	2.17	7.880	3.17	4.080	4.080	4.080
.25	3.890	1.25	135.630	2.25	6.750	3.25	3.800	3.800	3.800
.33	3.890	1.33	135.630	2.33	6.750	3.33	3.800	3.800	3.800
.42	4.560	1.42	33.220	2.42	5.930	3.42	3.560	3.560	3.560
.50	4.560	1.50	33.220	2.50	5.930	3.50	3.560	3.560	3.560
.58	5.550	1.58	17.550	2.58	5.300	3.58	3.350	3.350	3.350
.67	5.550	1.67	17.550	2.67	5.300	3.67	3.350	3.350	3.350
.75	7.230	1.75	12.240	2.75	4.810	3.75	3.160	3.160	3.160
.83	7.230	1.83	12.240	2.83	4.810	3.83	3.160	3.160	3.160
.92	10.770	1.92	9.540	2.92	4.410	3.92	3.000	3.000	3.000
1.00	10.770	2.00	9.540	3.00	4.410	4.00	3.000	3.000	3.000

004:0003-----

SITE 772 WINSTON CHURCHILL

* PAVED AREAS AND LANDSCAPED AREAS

| CALIB STANDHYD | Area (ha)= 5.90
| 01:001 | DT= 1.00 | Total Imp(%)= 90.00 Dir. Conn.(%)= 90.00

Surface Area (ha)= 5.31 IMPERVIOUS PERVIOUS (i)
Dep. Storage (mm)= 2.00 5.00 .59
Average Slope (%)= 1.00 2.00 2.00
Length (m)= 30.00 40.00 40.00
Mannings n = .013 .250
Max.eff.Inten.(mm/hr)= 135.63 27.75
over (min) 1.00 13.00
Storage Coeff. (min)= 1.10 (ii) 12.88 (ii)
Unit Hyd. Tpeak (min)= 1.00 13.00
Unit Hyd. peak (cms)= 1.02 .09
PEAK FLOW (cms)= 2.00 .03 *TOTALS*
TIME TO PEAK (hrs)= 1.33 1.52 2.012 (iii)
RUNOFF VOLUME (mm)= 52.14 15.28 1.333
TOTAL RAINFALL (mm)= 54.14 54.14 48.454
RUNOFF COEFFICIENT = .96 .28 54.140
.895

(i) CN PROCEDURE SELECTED FOR PERVIOUS LOSSES:
CN* = 70.0 Ia = Dep. Storage (Above)
(ii) TIME STEP (DT) SHOULD BE SMALLER OR EQUAL
THAN THE STORAGE COEFFICIENT.
(iii) PEAK FLOW DOES NOT INCLUDE BASEFLOW IF ANY.

004:0004-----
*

* BUILDING AREAS WITH CONTROLLED FLOW ROOF DRAINS

| CALIB STANDHYD | Area (ha)= 6.01
| 02:002 | DT= 1.00 | Total Imp(%)= 99.00 Dir. Conn.(%)= 99.00

Surface Area (ha)= 5.95 IMPERVIOUS PERVIOUS (i)
Dep. Storage (mm)= 2.00 5.00 .06
Average Slope (%)= 1.00 2.00 5.00
Length (m)= 30.00 40.00 40.00
Mannings n = .013 .250
Max.eff.Inten.(mm/hr)= 135.63 27.75
over (min) 1.00 13.00
Storage Coeff. (min)= 1.10 (ii) 12.88 (ii)
Unit Hyd. Tpeak (min)= 1.00 13.00
Unit Hyd. peak (cms)= 1.02 .09
PEAK FLOW (cms)= 2.24 .00 *TOTALS*
TIME TO PEAK (hrs)= 1.33 1.52 2.243 (iii)
RUNOFF VOLUME (mm)= 52.14 15.28 1.333
TOTAL RAINFALL (mm)= 54.14 54.14 51.771
RUNOFF COEFFICIENT = .96 .28 54.140
.956

(i) CN PROCEDURE SELECTED FOR PERVIOUS LOSSES:

- CN* = 70.0 Ia = Dep. Storage (Above)
- (ii) TIME STEP (DT) SHOULD BE SMALLER OR EQUAL THAN THE STORAGE COEFFICIENT.
- (iii) PEAK FLOW DOES NOT INCLUDE BASEFLOW IF ANY.

004:0005-----
 * CONTROLLED FLOW ROOF DRAINS - BLDG A & B

ROUTE RESERVOIR
 IN>02: (002) Requested routing time step = 1.0 min.
 OUT<03: (000200) -----

OUTFLOW (cms)	STORAGE (ha.m.)	OUTFLOW (cms)	STORAGE (ha.m.)
.000	.0000E+00	.232	.5062E+00
.140	.2058E+00	2.000	.5070E+00
.186	.3560E+00	.000	.0000E+00

ROUTING RESULTS
 INFLOW >02: (002) AREA (ha) QPEAK (cms) TPEAK (hrs) R.V. (mm)
 6.01 2.243 1.333 51.771
 OUTFLOW<03: (000200) AREA (ha) QPEAK (cms) TPEAK (hrs) R.V. (mm)
 6.01 2.017 2.017 51.771
 OVERFLOW<07: (001007) AREA (ha) QPEAK (cms) TPEAK (hrs) R.V. (mm)
 .00 .000 .000 .000

TOTAL NUMBER OF SIMULATED OVERFLOWS = 0
 CUMULATIVE TIME OF OVERFLOWS (hours) = .00
 PERCENTAGE OF TIME OVERFLOWING (%) = .00

PEAK FLOW REDUCTION [Qout/Qin](%) = 6.371
 TIME SHIFT OF PEAK FLOW (min) = 41.00
 MAXIMUM STORAGE USED (ha.m.) = .2149E+00

004:0006-----
 | ADD HYD (000503) | ID: NHYD AREA (ha) QPEAK (cms) TPEAK (hrs) R.V. (mm) DWF (cms)
 |-----|-----|-----|-----|-----|-----|-----|-----|
 ID1 01:001 5.90 2.012 1.33 48.45 .000
 +ID2 03:000200 6.01 .143 2.02 51.77 .000
 +ID3 07:001007 .00 .000 .00 .000 **DRY**
 =====
 SUM 04:000503 11.91 2.122 1.33 50.13 .000

NOTE: PEAK FLOWS DO NOT INCLUDE BASEFLOWS IF ANY.

004:0007-----
 *STORMWATER MANAGEMENT
 *BELOW GROUND STORAGE SYSTEM
 *BOTTOM ELEV:90.0m ; TOP ELEV 92.06
 *EROS/EXT ELEV 91.10, EROS VOL 2,581m3
 *ORIFICE 1: ELEV 89.15, 63mm ORIFICE
 *ORIFICE 2: ELEV 91.80, 260mm DIA.
 *STORMTECH CHAMBERS MC-4500 - 1,837m3
 *SURFACE DRY POND AREA - 3,405m3
 *SURFACE STORAGE - 0.25m DEEP - 820m3
 *TOTAL VOLUME: 5,077 m3

ROUTE RESERVOIR
 IN>04: (000503) Requested routing time step = 1.0 min.
 OUT<05: (000201) -----

OUTFLOW (cms)	STORAGE (ha.m.)	OUTFLOW (cms)	STORAGE (ha.m.)
.000	.0000E+00	.014	.2233E+00
.008	.7000E-02	.014	.2366E+00
.009	.1430E-01	.014	.2496E+00
.010	.4160E-01	.014	.2629E+00
.010	.7150E-01	.054	.2764E+00
.011	.1023E+00	.068	.2841E+00
.012	.1309E+00	.128	.3242E+00
.012	.1468E+00	.170	.3792E+00
.012	.1626E+00	.204	.4455E+00
.013	.1937E+00	.219	.5653E+00

ROUTING RESULTS
 INFLOW >04: (000503) AREA (ha) QPEAK (cms) TPEAK (hrs) R.V. (mm)
 11.91 2.122 1.333 50.127
 OUTFLOW<05: (000201) AREA (ha) QPEAK (cms) TPEAK (hrs) R.V. (mm)
 11.91 .138 4.017 50.128

PEAK FLOW REDUCTION [Qout/Qin](%) = 6.507
 TIME SHIFT OF PEAK FLOW (min) = 161.00
 MAXIMUM STORAGE USED (ha.m.) = .3376E+00

004:0008-----
 *PRINT HYD ID = 5 # OF PCYCLES=1
 * MODEL SIMULATION OF THE THREE STAGES OF PUMPING
 * P1=14 l/s, P1+P2=76l/s, P1+P2+P3=221 l/s

ROUTE RESERVOIR
 IN>04: (000503) Requested routing time step = 1.0 min.
 OUT<06: (000200) -----

OUTFLOW (cms)	STORAGE (ha.m.)	OUTFLOW (cms)	STORAGE (ha.m.)
.000	.0000E+00	.076	.4277E+00
.012	.1000E-02	.211	.4287E+00
.014	.2496E+00	.221	.5653E+00
.075	.2600E+00	.000	.0000E+00

ROUTING RESULTS
 INFLOW >04: (000503) AREA (ha) QPEAK (cms) TPEAK (hrs) R.V. (mm)
 11.91 2.122 1.333 50.127
 OUTFLOW<06: (000200) AREA (ha) QPEAK (cms) TPEAK (hrs) R.V. (mm)
 11.91 .076 5.850 50.128

PEAK FLOW REDUCTION [Qout/Qin](%) = 3.567
 TIME SHIFT OF PEAK FLOW (min) = 271.00
 MAXIMUM STORAGE USED (ha.m.) = .3726E+00

004:0009-----

 004:0002-----
 004:0002-----
 004:0002-----
 004:0002-----

```

** END OF RUN : 4
*****
| START | Project dir.: C:\PROGRA~1\SWHMYM\Projects\2256\
| Rainfall dir.: C:\PROGRA~1\SWHMYM\Projects\2256\
| TZERO = .00 hrs on
| METOUT= 2 (output = METRIC)
| NRUN = 005
| NSTORM= 1
| # 1=CHIC25YR.STM
*****
005:0002-----
# *****
# Project Name: 772 Winston Churchill Blvd., Oakville
# Project Number: 2256
# Date : DECEMBER 2022
# Modeller : FP
# Company : a.m. candaras associates inc.
# License # : 3813174
# Revision : C
# *****

```

```

005:0002-----
*

```

File name: C:\PROGRA~1\SWHMYM\Projects\2256\CHIC25
Comments: *BLOOR ST STAT DATA 10 MIN DISCRITIZATIO

TIME	RAIN	TIME	RAIN	TIME	RAIN	TIME	RAIN
hrs	mm/hr	hrs	mm/hr	hrs	mm/hr	hrs	mm/hr
.08	4.040	1.08	27.240	2.08	9.030	3.08	4.800
.17	4.040	1.17	27.240	2.17	9.030	3.17	4.800
.25	4.590	1.25	159.940	2.25	7.790	3.25	4.480
.33	4.590	1.33	159.940	2.33	7.790	3.33	4.480
.42	5.340	1.42	35.500	2.42	6.880	3.42	4.200
.50	5.340	1.50	35.500	2.50	6.880	3.50	4.200
.58	6.460	1.58	19.320	2.58	6.190	3.58	3.960
.67	6.460	1.67	19.320	2.67	6.190	3.67	3.960
.75	8.320	1.75	13.740	2.75	5.630	3.75	3.750
.83	8.320	1.83	13.740	2.83	5.630	3.83	3.750
.92	12.160	1.92	10.840	2.92	5.180	3.92	3.570
1.00	12.160	2.00	10.840	3.00	5.180	4.00	3.570

```

005:0003-----
# *****
# SITE 772 WINSTON CHURCHILL*
# *****
*
* PAVED AREAS AND LANDSCAPED AREAS
| CALIB STANDHYD | Area (ha)= 5.90
| 01:001 | Total Imp(%)= 90.00 Dir. Conn.(%)= 90.00
| DT= 1.00

```

```

| IMPERVIOUS | PERVIOUS (i)
| (ha)= 5.31 | .59
| Dep. Storage (mm)= 2.00 | 5.00
| Average Slope (%)= 1.00 | 2.00
| Length (m)= 30.00 | 40.00
| Mannings n = .013 | .250
| Max.eff.Inten.(mm/hr)= 159.94 | 41.33
| over (min) | 11.00
| Storage Coeff. (min)= 1.03 (ii) | 11.08 (ii)
| Unit Hyd. Tpeak (min)= 1.00 | 11.00
| Unit Hyd. peak (cms)= 1.06 | .10
| PEAK FLOW (cms)= 2.36 | .04
| TIME TO PEAK (hrs)= 1.33 | 1.48
| RUNOFF VOLUME (mm)= 60.16 | 19.68
| TOTAL RAINFALL (mm)= 62.16 | 62.16
| RUNOFF COEFFICIENT = .97 | .32
| *TOTALS* |
| 2.380 (iii) |
| 1.333 |
| 56.110 |
| 62.158 |
| .903 |

```

(i) CN PROCEDURE SELECTED FOR PERVIOUS LOSSES:
CN* = 70.0 Ia = Dep. Storage (Above)
(ii) TIME STEP (DT) SHOULD BE SMALLER OR EQUAL THAN THE STORAGE COEFFICIENT.
(iii) PEAK FLOW DOES NOT INCLUDE BASEFLOW IF ANY.

```

005:0004-----
*
* BUILDING AREAS WITH CONTROLLED FLOW ROOF DRAINS
| CALIB STANDHYD | Area (ha)= 6.01
| 02:002 | DT= 1.00 | Total Imp(%)= 99.00 Dir. Conn.(%)= 99.00

```

Area (ha)= 6.01
Total Imp(%)= 99.00 Dir. Conn.(%)= 99.00

IMPERVIOUS	PERVIOUS (i)
Surface Area (ha)= 5.95	.06
Dep. Storage (mm)= 2.00	5.00
Average Slope (%)= 1.00	2.00
Length (m)= 30.00	40.00
Mannings n = .013	.250
Max.eff.Inten.(mm/hr)= 159.94	41.33
over (min) 1.00	11.00
Storage Coeff. (min)= 1.03 (ii) 11.08 (ii)	
Unit Hyd. Tpeak (min)= 1.00	11.00
Unit Hyd. peak (cms)= 1.06	.10
PEAK FLOW (cms)= 2.64	.00
TIME TO PEAK (hrs)= 1.33	1.48
RUNOFF VOLUME (mm)= 60.16	19.68
TOTAL RAINFALL (mm)= 62.16	62.16
RUNOFF COEFFICIENT = .97	.32
TOTALS	
2.646 (iii)	
1.333	
59.754	
62.158	
.961	

```

| (i) CN PROCEDURE SELECTED FOR PERVIOUS LOSSES:
| CN* = 70.0 Ia = Dep. Storage (Above)
| (ii) TIME STEP (DT) SHOULD BE SMALLER OR EQUAL
| THAN THE STORAGE COEFFICIENT.
| (iii) PEAK FLOW DOES NOT INCLUDE BASEFLOW IF ANY.
005:0005-----

```

```

* CONTROLLED FLOW ROOF DRAINS - BLDG A & B
-----
ROUTE RESERVOIR
IN>02:(002 )
OUT<03:(000200)
-----
Requested routing time step = 1.0 min.
===== OUTFLOW STORAGE TABLE =====
OUTFLOW STORAGE OUTFLOW STORAGE
(cms) (ha.m.) (cms) (ha.m.)
.000 .0000E+00 .232 .5062E+00
.140 .2058E+00 2.000 .5070E+00
.186 .3560E+00 .000 .0000E+00
-----
ROUTING RESULTS
-----
INFLOW >02: (002 ) TPEAK (hrs) R.V. (mm)
6.01 2.646 1.333 59.754
OUTFLOW<03: (000200) QPEAK (cms)
6.01 .153 2.050 59.753
OVERFLOW<07: (001007) .00 .000 .000 .000
-----
TOTAL NUMBER OF SIMULATED OVERFLOWS = 0
CUMULATIVE TIME OF OVERFLOWS (hours) = .00
PERCENTAGE OF TIME OVERFLOWING (%) = .00
-----
PEAK FLOW REDUCTION [Qout/Qin](%) = 5.798
TIME SHIFT OF PEAK FLOW (min) = 43.00
MAXIMUM STORAGE USED (ha.m.) = .2492E+00
-----
005:0006
-----
| ADD HYD (000503) | ID: NHYD | AREA (ha) | QPEAK (cms) | TPEAK (hrs) | R.V. (mm) | DWF (cms) |
|-----|-----|-----|-----|-----|-----|-----|
| ID1 01:001 | | 5.90 | 2.380 | 1.33 | 56.11 | .000 |
| +ID2 03:000200 | | 6.01 | .153 | 2.05 | 59.75 | .000 |
| +ID3 07:001007 | | .00 | .000 | .00 | .00 | .000 |
|-----|-----|-----|-----|-----|-----|
| SUM 04:000503 | 11.91 | 2.509 | 1.33 | 57.95 | .000 |
-----
NOTE: PEAK FLOWS DO NOT INCLUDE BASEFLOWS IF ANY.
-----
005:0007
-----
*STORMWATER MANAGEMENT
*BELOW GROUND STORAGE SYSTEM
*BOTTOM ELEV:90.0m ; TOP ELEV 92.06
*EROS/EXT ELEV 91.10, EROS VOL 2,581m3
*ORIFICE 1: ELEV 89.15, 63mm ORIFICE
*ORIFICE 2: ELEV 91.80, 260mm DIA.
*STORMTECH CHAMBERS MC-4500 - 1,837m3
*SURFACE DRY POND AREA - 3,405m3
*SURFACE STORAGE - 0.25m DEEP - 820m3
*TOTAL VOLUME: 5,077 m3
-----
Requested routing time step = 1.0 min.
===== OUTFLOW STORAGE TABLE =====
OUTFLOW STORAGE OUTFLOW STORAGE
(cms) (ha.m.) (cms) (ha.m.)
.000 .0000E+00 .014 .2233E+00
-----
ROUTE RESERVOIR
IN>04:(000503)
OUT<05:(000201)
-----

```

```

.008 .7000E-02 .014 .2366E+00
.009 .1430E-01 .014 .2496E+00
.010 .4160E-01 .014 .2629E+00
.010 .7150E-01 .054 .2764E+00
.011 .1023E+00 .068 .2841E+00
.012 .1309E+00 .128 .3242E+00
.012 .1468E+00 .170 .3792E+00
.012 .1626E+00 .204 .4455E+00
.013 .1937E+00 .219 .5653E+00
-----
ROUTING RESULTS
-----
INFLOW >04: (000503) AREA (ha) QPEAK (cms) TPEAK (hrs) R.V. (mm)
11.91 2.509 1.333 57.948
OUTFLOW<05: (000201) 11.91 .162 4.017 57.948
-----
PEAK FLOW REDUCTION [Qout/Qin](%) = 6.440
TIME SHIFT OF PEAK FLOW (min) = 161.00
MAXIMUM STORAGE USED (ha.m.) = .3680E+00
-----
005:0008
-----
*PRINT HYD ID = 5 # OF PCYCLES=1
* MODEL SIMULATION OF THE THREE STAGES OF PUMPING
* P1=14 l/s, P1+P2=76l/s, P1+P2+P3=221 l/s
-----
Requested routing time step = 1.0 min.
===== OUTFLOW STORAGE TABLE =====
OUTFLOW STORAGE OUTFLOW STORAGE
(cms) (ha.m.) (cms) (ha.m.)
.000 .0000E+00 .076 .4277E+00
.012 .1000E-02 .211 .4287E+00
.014 .2496E+00 .221 .5653E+00
.075 .2600E+00 .000 .0000E+00
-----
ROUTING RESULTS
-----
INFLOW >04: (000503) AREA (ha) QPEAK (cms) TPEAK (hrs) R.V. (mm)
11.91 2.509 1.333 57.948
OUTFLOW<06: (000200) 11.91 .113 4.917 57.948
-----
PEAK FLOW REDUCTION [Qout/Qin](%) = 4.516
TIME SHIFT OF PEAK FLOW (min) = 215.00
MAXIMUM STORAGE USED (ha.m.) = .4280E+00
-----
005:0009
-----
005:0002
-----
005:0002
-----
005:0002
-----
** END OF RUN : 5
-----

```

```

-----
| START | Project dir.: C:\PROGRA-1\SWHMYM\Projects\2256\
|-----| Rainfall dir.: C:\PROGRA-1\SWHMYM\Projects\2256\
TZERO = .00 hrs on
METOUT= 2 (output = METRIC)
NRUN = 006
NSTORM= 1
# 1=CHIC50YR.STM
-----
006:0002-----
** Project Name: 772 Winston Churchill Blvd., Oakville
** Project Number: 2256
** Date : DECEMBER 2022
** Modeller : FP
** Company : a.m. candaras associates inc.
** License # : 3813174
** Revision : C
**-----**

```

006:0002-----

File name: C:\PROGRA-1\SWHMYM\Projects\2256\CHIC50
Comments: *BLOOR ST STAT DATA 10 MIN DISCRITIZATIO

TIME	RAIN	TIME	RAIN	TIME	RAIN
hrs	mm/hr	hrs	mm/hr	hrs	mm/hr
.08	4.162	1.08	32.657	2.08	9.717
.17	4.162	1.17	32.657	2.17	9.717
.25	4.763	1.25	184.617	2.25	8.288
.33	4.763	1.33	184.617	2.33	8.288
.42	5.601	1.42	43.091	2.42	7.254
.50	5.601	1.50	43.091	2.50	7.254
.58	6.862	1.58	22.223	2.58	6.469
.67	6.862	1.67	22.223	2.67	6.469
.75	9.002	1.75	15.316	2.75	5.851
.83	9.002	1.83	15.316	2.83	5.851
.92	13.574	1.92	11.832	2.92	5.351
1.00	13.574	2.00	11.832	3.00	5.351

006:0003-----

SITE 772 WINSTON CHURCHILL

* PAVED AREAS AND LANDSCAPED AREAS

CALIB STANDHYD	Area	(ha)	5.90	Dir. Conn. (%)	90.00
DT= 1.00	Total Imp(%)	=	90.00	Dir. Conn. (%)	=
Surface Area	(ha)	=	5.31	PERVIOUS (i)	
Dep. Storage	(mm)	=	2.00	5.00	.59
Average Slope	(%)	=	1.00	2.00	
Length	(m)	=	30.00	40.00	

```

Mannings n = .013 .250
Max.eff.Inten.(mm/hr) = 184.62 57.36
over (min) = 1.00 10.00
Storage Coeff. (min) = .97 (ii) 9.79 (ii)
Unit Hyd. Tpeak (min) = 1.00 10.00
Unit Hyd. peak (cms) = 1.09 .11
*TOTALS*
PEAK FLOW (cms) = 2.72 .06 2.757 (iii)
TIME TO PEAK (hrs) = 1.33 1.47 1.333
RUNOFF VOLUME (mm) = 68.32 24.49 63.934
TOTAL RAINFALL (mm) = 70.32 70.32 70.316
RUNOFF COEFFICIENT = .97 .35 .909

```

(i) CN PROCEDURE SELECTED FOR PERVIOUS LOSSES:
CN* = 70.0 Ia = Dep. Storage (Above)
(ii) TIME STEP (DT) SHOULD BE SMALLER OR EQUAL THAN THE STORAGE COEFFICIENT.
(iii) PEAK FLOW DOES NOT INCLUDE BASEFLOW IF ANY.

006:0004-----

* BUILDING AREAS WITH CONTROLLED FLOW ROOF DRAINS

CALIB STANDHYD	Area	(ha)	6.01	Dir. Conn. (%)	99.00
DT= 1.00	Total Imp(%)	=	99.00	Dir. Conn. (%)	=
Surface Area	(ha)	=	5.95	PERVIOUS (i)	
Dep. Storage	(mm)	=	2.00	5.00	.06
Average Slope	(%)	=	1.00	2.00	
Length	(m)	=	30.00	40.00	
Mannings n		=	.013	.250	
Max.eff.Inten.(mm/hr) =	184.62	57.36			
over (min) =	1.00	10.00			
Storage Coeff. (min) =	.97 (ii)	9.79 (ii)			
Unit Hyd. Tpeak (min) =	1.00	10.00			
Unit Hyd. peak (cms) =	1.09	.11			
PEAK FLOW (cms) =	3.05	.01			
TIME TO PEAK (hrs) =	1.33	1.47			
RUNOFF VOLUME (mm) =	68.32	24.49			
TOTAL RAINFALL (mm) =	70.32	70.32			
RUNOFF COEFFICIENT =	.97	.35			

(i) CN PROCEDURE SELECTED FOR PERVIOUS LOSSES:
CN* = 70.0 Ia = Dep. Storage (Above)
(ii) TIME STEP (DT) SHOULD BE SMALLER OR EQUAL THAN THE STORAGE COEFFICIENT.
(iii) PEAK FLOW DOES NOT INCLUDE BASEFLOW IF ANY.

006:0005-----

* CONTROLLED FLOW ROOF DRAINS - BLDG A & B

ROUTE RESERVOIR	Requested routing time step =	1.0 min.
IN>02: (002)	=====	OUTFLOW STORAGE TABLE
OUT<03: (000200)	=====	=====

```

ROUTING RESULTS
-----
INFLOW >02: (002)
OUTFLOW<03: (000200)
OVERFLOW<07: (001007)

TOTAL NUMBER OF SIMULATED OVERFLOWS = 0
CUMULATIVE TIME OF OVERFLOWS (hours) = .00
PERCENTAGE OF TIME OVERFLOWING (%) = .00

PEAK FLOW REDUCTION [Qout/Qin](%) = 5.443
TIME SHIFT OF PEAK FLOW (min) = 42.00
MAXIMUM STORAGE USED (ha.m.) = .2912E+00
    
```

```

ROUTING RESULTS
-----
INFLOW >04: (000503)
OUTFLOW<05: (000201)

PEAK FLOW REDUCTION [Qout/Qin](%) = 6.192
TIME SHIFT OF PEAK FLOW (min) = 161.00
MAXIMUM STORAGE USED (ha.m.) = .3977E+00
    
```

```

006:0006
-----
*PRINT HYD ID = 5 # OF PCYCLES=1
* MODEL SIMULATION OF THE THREE STAGES OF PUMPING
* P1=14 l/s, P1+P2=76l/s, P1+P2+P3=221 l/s
    
```

```

ROUTE RESERVOIR
IN>04: (000503)
OUT<06: (000200)

Requested routing time step = 1.0 min.
    
```

```

006:0007
-----
| ADD HYD (000503) | ID: NHYD | AREA (ha) | QPEAK (cms) | TPEAK (hrs) | R.V. (mm) | DWF (cms) |
|-----|-----|-----|-----|-----|-----|-----|
| ID1 01:001 | | 5.90 | 2.757 | 1.33 | 63.93 | .000 |
| +ID2 03:000200 | | 6.01 | 1.66 | 2.03 | 67.88 | .000 |
| +ID3 07:001007 | | .00 | .000 | .00 | .00 | .000 |
|-----|-----|-----|-----|-----|-----|
| SUM 04:000503 | | 11.91 | 2.901 | 1.33 | 65.92 | .000 |
    
```

NOTE: PEAK FLOWS DO NOT INCLUDE BASEFLOWS IF ANY.

```

006:0007
-----
*STORMWATER MANAGEMENT
*BELOW GROUND STORAGE SYSTEM
*BOTTOM ELEV:90.0m ; TOP ELEV 92.06
*EROS/EXT ELEV 91.10, EROS VOL 2,581m3
*ORIFICE 1: ELEV 89.15, 63mm ORIFICE
*ORIFICE 2: ELEV 91.80, 260mm DIA.
*STORMTECH CHAMBERS MC-4500 - 1,837m3
*SURFACE DRY POND AREA - 3,405m3
*SURFACE STORAGE - 0.25m DEEP - 820m3
*TOTAL VOLUME: 5,077 m3
    
```

```

ROUTE RESERVOIR
IN>04: (000503)
OUT<05: (000201)

Requested routing time step = 1.0 min.
=====
OUTFLOW STORAGE TABLE
=====
OUTFLOW (cms) | STORAGE (ha.m.) |
-----|-----|
.000 | .0000E+00 |
.008 | 7.000E-02 |
.009 | 1.430E-01 |
.010 | 4.160E-01 |
.011 | 7.150E-01 |
.068 | 1.023E+00 |
    
```

```

ROUTING RESULTS
-----
INFLOW >04: (000503)
OUTFLOW<06: (000200)

PEAK FLOW REDUCTION [Qout/Qin](%) = 6.192
TIME SHIFT OF PEAK FLOW (min) = 161.00
MAXIMUM STORAGE USED (ha.m.) = .3977E+00
    
```

```

006:0008
-----
*PRINT HYD ID = 5 # OF PCYCLES=1
* MODEL SIMULATION OF THE THREE STAGES OF PUMPING
* P1=14 l/s, P1+P2=76l/s, P1+P2+P3=221 l/s
    
```

```

ROUTE RESERVOIR
IN>04: (000503)
OUT<06: (000200)

Requested routing time step = 1.0 min.
    
```

```

ROUTING RESULTS
-----
INFLOW >04: (000503)
OUTFLOW<06: (000200)

PEAK FLOW REDUCTION [Qout/Qin](%) = 7.279
TIME SHIFT OF PEAK FLOW (min) = 152.00
MAXIMUM STORAGE USED (ha.m.) = .4307E+00
    
```

```

006:0009
-----
*****
006:0002
-----
006:0002
-----
006:0002
-----
006:0002
-----
006:0002
-----
006:0002
-----
006:0002
-----
006:0002
-----
    
```

** END OF RUN : 6

```

-----
| START | Project dir.: C:\PROGRA-1\SWMHYMO\Projects\2256\
|-----| Rainfall dir.: C:\PROGRA-1\SWMHYMO\Projects\2256\
TZERO = .00 hrs on
METOUT= 2 (output = METRIC)
NRUN = 007
NSTORM= 1
# 1=CH100YR.STM
007:0002-----
** Project Name: 772 Winston Churchill Blvd., Oakville
** Project Number: 2256
** Date : DECEMBER 2022
** Modeller : FP
** Company : a.m. candaras associates inc.
** License # : 3813174
** Revision : C
**
007:0002-----

```

007:0002-----

File Name: C:\PROGRA-1\SWMHYMO\Projects\2256\CH100Y
Comments: *BLOOR ST STAT DATA 10 MIN DISCRITIZATIO

TIME	RAIN	TIME	RAIN	TIME	RAIN
hrs	mm/hr	hrs	mm/hr	hrs	mm/hr
.08	4.310	1.08	38.040	2.08	10.640
.17	4.310	1.17	38.040	2.17	10.640
.25	4.960	1.25	203.310	2.25	8.990
.33	4.960	1.33	203.310	2.33	8.990
.42	5.880	1.42	51.040	2.42	7.810
.50	5.880	1.50	51.040	2.50	7.810
.58	7.270	1.58	25.590	2.58	6.920
.67	7.270	1.67	25.590	2.67	6.920
.75	9.690	1.75	17.240	2.75	6.230
.83	9.690	1.83	17.240	2.83	6.230
.92	15.000	1.92	13.110	2.92	5.670
1.00	15.000	2.00	13.110	3.00	5.670

007:0003-----

```

*****
**SITE 772 WINSTON CHURCHILL*
*****
* PAVED AREAS AND LANDSCAPED AREAS

```

CALIB STANDHYD	Area	(ha)=	5.90	Dir. Conn. (%) =	90.00
01:001	DT= 1.00	Total Imp(%)=	90.00	Dir. Conn. (%) =	90.00
Surface Area	(ha) =	5.31	PERVIOUS	PERVIOUS (i)	
Dep. Storage	(mm) =	2.00	5.00	5.99	
Average Slope	(%) =	1.00	2.00	2.00	
Length	(m) =	30.00	40.00	40.00	
Mannings n	=	.013	.250	.250	
Max.eff.Inten. (mm/hr)=		203.31	72.73	72.73	

```

-----
| over (min) | 1.00 | 9.00 |
| Storage Coeff. (min) = | .93 (ii) | 8.95 (ii) |
| Unit Hyd. Tpeak (min) = | 1.00 | 9.00 |
| Unit Hyd. peak (cms) = | 1.12 | .13 |
PEAK FLOW (cms) = 3.00 .07 *TOTALS*
TIME TO PEAK (hrs) = 1.33 1.45 3.046 (iii)
RUNOFF VOLUME (mm) = 76.03 29.32 1.333
TOTAL RAINFALL (mm) = 78.03 78.03 71.361
RUNOFF COEFFICIENT = .97 78.03 78.032
.915
(i) CN PROCEDURE SELECTED FOR PERVIOUS LOSSES:
CN* = 70.0 Ia = Dep. Storage (Above)
(ii) TIME STEP (DT) SHOULD BE SMALLER OR EQUAL
THAN THE STORAGE COEFFICIENT.
(iii) PEAK FLOW DOES NOT INCLUDE BASEFLOW IF ANY.
007:0004-----

```

007:0004-----

* BUILDING AREAS WITH CONTROLLED FLOW ROOF DRAINS

CALIB STANDHYD	Area	(ha)=	6.01	Dir. Conn. (%) =	99.00
02:002	DT= 1.00	Total Imp(%)=	99.00	Dir. Conn. (%) =	99.00
Surface Area	(ha) =	5.95	PERVIOUS (i)	PERVIOUS (i)	
Dep. Storage	(mm) =	2.00	5.00	5.06	
Average Slope	(%) =	1.00	2.00	2.00	
Length	(m) =	30.00	40.00	40.00	
Mannings n	=	.013	.250	.250	
Max.eff.Inten. (mm/hr)=		203.31	72.73	72.73	
Storage Coeff. (min) =		1.00	9.00	9.00	
Unit Hyd. Tpeak (min) =		.93 (ii)	8.95 (ii)	8.95 (ii)	
Unit Hyd. peak (cms) =		1.00	9.00	9.00	
PEAK FLOW (cms) =		1.12	.13	.13	
TIME TO PEAK (hrs) =		3.36	.01	.01	
RUNOFF VOLUME (mm) =		1.33	1.45	1.45	
TOTAL RAINFALL (mm) =		76.03	29.32	29.32	
RUNOFF COEFFICIENT =		78.03	78.03	78.03	
		.97	.38	.38	

007:0005-----

```

(i) CN PROCEDURE SELECTED FOR PERVIOUS LOSSES:
CN* = 70.0 Ia = Dep. Storage (Above)
(ii) TIME STEP (DT) SHOULD BE SMALLER OR EQUAL
THAN THE STORAGE COEFFICIENT.
(iii) PEAK FLOW DOES NOT INCLUDE BASEFLOW IF ANY.
007:0005-----

```

* CONTROLLED FLOW ROOF DRAINS - BLDG A & B

ROUTE RESERVOIR	Requested routing time step =	1.0 min.
IN<02: (002)	=====	=====
OUT<03: (000200)	=====	=====
OUTFLOW STORAGE TABLE	=====	=====
OUTFLOW STORAGE (ha.m.)	=====	=====
OUTFLOW (cms)	=====	=====
	.000	.232
	.00000E+00	.5062E+00

```

ROUTING RESULTS
-----
INFLOW >02: (002 )
OUTFLOW<03: (000200)
OVERFLOW<07: (001007)
AREA QPEAK TPEAK R.V.
(ha) (cms) (hrs) (mm)
.140 .2058E+00 | 2.000 .5070E+00
.186 .3560E+00 | .000 .0000E+00
6.01 3.365 1.333 75.565
6.01 .178 2.067 75.564
.00 .000 .000 .000

```

```

TOTAL NUMBER OF SIMULATED OVERFLOWS = 0
CUMULATIVE TIME OF OVERFLOWS (hours) = .00
PERCENTAGE OF TIME OVERFLOWING (%) = .00

```

```

PEAK FLOW REDUCTION [Qout/Qin] (%) = 5.288
TIME SHIFT OF PEAK FLOW (min) = 44.00
MAXIMUM STORAGE USED (ha.m.) = .3294E+00

```

007:0006

```

-----
| ADD HYD (000503) | ID: NHYD AREA QPEAK TPEAK R.V. DMF
-----
| 01:001 | 5.90 3.046 1.33 71.36 .000
| 03:00200 | 6.01 .178 2.07 75.56 .000
| 07:001007 | .00 .000 .00 .00 .000 **DRY**
-----
SUM 04:000503 11.91 3.198 1.33 73.48 .000

```

NOTE: PEAK FLOWS DO NOT INCLUDE BASEFLOWS IF ANY.

```

*****
*STORMWATER MANAGEMENT
*BELOW GROUND STORAGE SYSTEM
*BOTTOM ELEV:90.0m ; TOP ELEV 92.06
*EROS/EXT ELEV 91.10, EROS VOL 2,581m3
*ORIFICE 1: ELEV 89.15, 63mm ORIFICE
*ORIFICE 2: ELEV 91.80, 260mm DIA.
*STORMTECH CHAMBERS MC-4500 - 1,837m3
*SURFACE DRY POND AREA - 3,405m3
*SURFACE STORAGE - 0.25m DEEP - 820m3
*TOTAL VOLUME: 5,077 m3
*****

```

Requested routing time step = 1.0 min.

```

-----
ROUTE RESERVOIR
IN>04: (000503)
OUT<05: (000201)
=====
OUTFLOW STORAGE TABLE
(cms) (ha.m.) (cms) (ha.m.)
.000 .0000E+00 .014 .2233E+00
.008 .7000E-02 .014 .2366E+00
.009 .1430E-01 .014 .2496E+00
.010 .4160E-01 .014 .2629E+00
.010 .7150E-01 .054 .2764E+00
.011 .1023E+00 .068 .2841E+00
.012 .1309E+00 .128 .3242E+00
.012 .1468E+00 .170 .3792E+00
.012 .1626E+00 .204 .4455E+00

```

```

ROUTING RESULTS
-----
INFLOW >04: (000503)
OUTFLOW<05: (000201)
AREA QPEAK TPEAK R.V.
(ha) (cms) (hrs) (mm)
.013 .1937E+00 | .219 .5653E+00
11.91 3.198 1.333 73.481
11.91 .196 4.017 73.481

```

```

PEAK FLOW REDUCTION [Qout/Qin] (%) = 6.136
TIME SHIFT OF PEAK FLOW (min) = 161.00
MAXIMUM STORAGE USED (ha.m.) = .4307E+00

```

007:0008

```

*PRINT HYD ID = 5 # OF PCYCLES=1
* MODEL SIMULATION OF THE THREE STAGES OF PUMPING
* P1=14 l/s, P1+P2=76l/s, P1+P2+P3=221 l/s

```

ROUTE RESERVOIR Requested routing time step = 1.0 min.

```

-----
IN>04: (000503)
OUT<06: (000200)
=====
OUTFLOW STORAGE TABLE
(cms) (ha.m.) (cms) (ha.m.)
.000 .0000E+00 .076 .4277E+00
.012 .1000E-02 .211 .4287E+00
.014 .2496E+00 .221 .5653E+00
.075 .2600E+00 .000 .0000E+00

```

```

ROUTING RESULTS
-----
INFLOW >04: (000503)
OUTFLOW<06: (000200)
AREA QPEAK TPEAK R.V.
(ha) (cms) (hrs) (mm)
11.91 3.198 1.333 73.481
11.91 .212 4.000 73.481

```

```

PEAK FLOW REDUCTION [Qout/Qin] (%) = 6.642
TIME SHIFT OF PEAK FLOW (min) = 160.00
MAXIMUM STORAGE USED (ha.m.) = .4483E+00

```

007:0009

007:0002

007:0002

007:0002

007:0002

007:0002

007:0002

** END OF RUN : 7

```

| START | Project dir.: C:\PROGRA-1\SWHMYO\Projects\2256\
----- Rainfall dir.: C:\PROGRA-1\SWHMYO\Projects\2256\
TZERO = .00 hrs on 0
METOUT= 2 (output = METRIC)
NRUN = 008
NSTORM= 1
# 1=2Y24HS.STM
008:0002-----
*#*****
** Project Name: 772 Winston Churchill Blvd., Oakville
** Project Number: 2256
** Date : DECEMBER 2022
** Modeller : FP
** Company : a.m. candaras associates inc.
** License # : 3813174
** Revision : C
*#*****
008:0002-----
*

```

Filename: C:\PROGRA-1\SWHMYO\Projects\2256\2Y24HS
Comments: * 2YR SCS 24hr STORM, 15min TIME STEPS,M

TIME	RAIN	TIME	RAIN	TIME	RAIN	TIME	RAIN	TIME	RAIN
hrs	mm/hr	hrs	mm/hr	hrs	mm/hr	hrs	mm/hr	hrs	mm/hr
6.25	1.030	12.25	7.400	18.25	.920	24.25	.920	30.25	.920
6.50	1.030	12.50	7.400	18.50	.920	24.50	.920	30.50	.920
6.75	1.030	12.75	3.800	18.75	.920	24.75	.920	30.75	.920
7.00	1.030	13.00	3.800	19.00	.920	25.00	.920	31.00	.920
7.25	1.030	13.25	7.200	19.25	.920	25.25	.920	31.25	.920
7.50	1.030	13.50	7.200	19.50	.920	25.50	.920	31.50	.920
7.75	1.030	13.75	4.210	19.75	.920	25.75	.920	31.75	.920
8.00	1.030	14.00	4.210	20.00	.920	26.00	.920	32.00	.920
8.25	1.390	14.25	1.540	20.25	.620	26.25	.620	32.25	.620
8.50	1.390	14.50	1.540	20.50	.620	26.50	.620	32.50	.620
8.75	1.390	14.75	1.540	20.75	.620	26.75	.620	32.75	.620
9.00	1.390	15.00	1.540	21.00	.620	27.00	.620	33.00	.620
9.25	1.640	15.25	1.540	21.25	.620	27.25	.620	33.25	.620
9.50	1.640	15.50	1.540	21.50	.620	27.50	.620	33.50	.620
9.75	1.850	15.75	1.540	21.75	.620	27.75	.620	33.75	.620
10.00	1.850	16.00	1.540	22.00	.620	28.00	.620	34.00	.620
10.25	2.360	16.25	9.200	22.25	.620	28.25	.620	34.25	.620
10.50	2.360	16.50	9.200	22.50	.620	28.50	.620	34.50	.620
10.75	3.190	16.75	9.200	22.75	.620	28.75	.620	34.75	.620
11.00	3.190	17.00	9.200	23.00	.620	29.00	.620	35.00	.620
11.25	4.930	17.25	9.200	23.25	.620	29.25	.620	35.25	.620
11.50	4.930	17.50	9.200	23.50	.620	29.50	.620	35.50	.620
11.75	21.380	17.75	9.200	23.75	.620	29.75	.620	35.75	.620
12.00	56.730	18.00	9.200	24.00	.620	30.00	.620	36.00	.620

```

008:0003-----
*****
** SITE 772 WINSTON CHURCHILL*
*****
*
* PAVED AREAS AND LANDSCAPED AREAS
-----

```

```

| CALIB STANDHYD | Area (ha)= 5.90 | Dir. Conn.(%)= 90.00
----- DT= 1.00 | Total Imp(%)= 90.00
Surface Area (ha)= 5.31 | IMPERVIOUS | PERVIOUS (i)
Dep. Storage (mm)= 2.00 | | 5.9
Average Slope (%)= 1.00 | | 2.00
Length (m)= 30.00 | | 40.00
Mannings n = .013 | | .250
Max.eff.Inten.(mm/hr)= 56.73 | 16.57
over (min)= 2.00 | 16.00
Storage Coeff. (min)= 1.56 (ii) | 16.04 (ii)
Unit Hyd. Tpeak (min)= 2.00 | 16.00
Unit Hyd. peak (cms)= .65 | .07
PEAK FLOW (cms)= .84 | .02
TIME TO PEAK (hrs)= 12.00 | 12.17
RUNOFF VOLUME (mm)= 49.39 | 13.86
TOTAL RAINFALL (mm)= 51.39 | 51.39
RUNOFF COEFFICIENT = .96 | .27
*TOTALS*
.849 (iii)
12.000
45.835
51.388
.892

```

(i) CN PROCEDURE SELECTED FOR PERVIOUS LOSSES:
CN* = 70.0 Ia = Dep. Storage (Above)
(ii) TIME STEP (DT) SHOULD BE SMALLER OR EQUAL THAN THE STORAGE COEFFICIENT.
(iii) PEAK FLOW DOES NOT INCLUDE BASEFLOW IF ANY.

008:0004-----
* BUILDING AREAS WITH CONTROLLED FLOW ROOF DRAINS

```

| CALIB STANDHYD | Area (ha)= 6.01 | Dir. Conn.(%)= 99.00
----- DT= 1.00 | Total Imp(%)= 99.00
Surface Area (ha)= 5.95 | IMPERVIOUS | PERVIOUS (i)
Dep. Storage (mm)= 2.00 | | 5.00
Average Slope (%)= 1.00 | | 2.00
Length (m)= 30.00 | | 40.00
Mannings n = .013 | | .250
Max.eff.Inten.(mm/hr)= 56.73 | 16.57
over (min)= 2.00 | 16.00
Storage Coeff. (min)= 1.56 (ii) | 16.04 (ii)
Unit Hyd. Tpeak (min)= 2.00 | 16.00
Unit Hyd. peak (cms)= .65 | .07
PEAK FLOW (cms)= .94 | .00
TIME TO PEAK (hrs)= 12.00 | 12.17
RUNOFF VOLUME (mm)= 49.39 | 13.86
TOTAL RAINFALL (mm)= 51.39 | 51.39
RUNOFF COEFFICIENT = .96 | .27
*TOTALS*
.939 (iii)
12.000
49.032
51.388
.954

```

(i) CN PROCEDURE SELECTED FOR PERVIOUS LOSSES:
CN* = 70.0 Ia = Dep. Storage (Above)
(ii) TIME STEP (DT) SHOULD BE SMALLER OR EQUAL THAN THE STORAGE COEFFICIENT.
(iii) PEAK FLOW DOES NOT INCLUDE BASEFLOW IF ANY.

008:0005
 * CONTROLLED FLOW ROOF DRAINS - BLDG A & B
 Requested routing time step = 1.0 min.
 ROUTE RESERVOIR
 IN>02:(002)
 OUT<03:(000200)

ROUTING RESULTS	AREA (ha)	QPEAK (cms)	TPEAK (hrs)	R.V. (mm)	STORAGE (ha.m.)
INFLOW >02: (002)	6.01	.939	12.000	49.032	.000
OUTFLOW <03: (000200)	6.01	.104	12.517	49.032	.232
OVERFLOW <07: (001007)	.00	.000	.000	.000	.5062E+00
					2.000
					.5070E+00
					.186
					.3560E+00
					.000
					.0000E+00

TOTAL NUMBER OF SIMULATED OVERFLOWS = 0
 CUMULATIVE TIME OF OVERFLOWS (hours) = .00
 PERCENTAGE OF TIME OVERFLOWING (%) = .00

PEAK FLOW REDUCTION [Qout/Qin](%) = 11.111
 TIME SHIFT OF PEAK FLOW (min) = 31.00
 MAXIMUM STORAGE USED (ha.m.) = .1533E+00

008:0006
 | ADD HYD (000503) | ID: NHYD
 ID1 01:001
 +ID2 03:000200
 +ID3 07:001007
 SUM 04:000503 11.91 .943 12.00 47.45 .000

NOTE: PEAK FLOWS DO NOT INCLUDE BASEFLOWS IF ANY.

008:0007
 *STORMWATER MANAGEMENT
 *BELOW GROUND STORAGE SYSTEM
 *BOTTOM ELEV:90.0m ; TOP ELEV 92.06
 *EROS/EXT ELEV 91.10, EROS VOL 2,581m3
 *ORIFICE 1: ELEV 89.15, 63mm ORIFICE
 *ORIFICE 2: ELEV 91.80, 260mm DIA.
 *STORMTECH CHAMBERS MC-4500 - 1,837m3
 *SURFACE DRY POND AREA - 3,405m3
 *SURFACE STORAGE - 0.25m DEEP - 820m3
 *TOTAL VOLUME: 5,077 m3

ROUTE RESERVOIR
 IN>04:(000503)
 OUT<05:(000201)

Requested routing time step = 1.0 min.

===== OUTFLOW STORAGE TABLE =====

ROUTING RESULTS	AREA (ha)	QPEAK (cms)	TPEAK (hrs)	R.V. (mm)	STORAGE (ha.m.)
INFLOW >04: (000503)	11.91	.943	12.000	47.448	.000
OUTFLOW <05: (000201)	11.91	.088	15.983	47.448	.014
					.2233E+00
					.014
					.7000E-02
					.014
					.1430E-01
					.014
					.4160E-01
					.014
					.7150E-01
					.054
					.2841E+00
					.068
					.1023E+00
					.128
					.1309E+00
					.170
					.1468E+00
					.204
					.1626E+00
					.219
					.1937E+00
					.5653E+00

PEAK FLOW REDUCTION [Qout/Qin](%) = 9.307
 TIME SHIFT OF PEAK FLOW (min) = 239.00
 MAXIMUM STORAGE USED (ha.m.) = .2973E+00

008:0008
 *PRINT HYD ID = 5 OF PCYCLES=1
 * MODEL SIMULATION OF THE THREE STAGES OF PUMPING
 * P1=14 1/s, P1+P2=761/s, P1+P2+P3=221 1/s
 Requested routing time step = 1.0 min.

ROUTE RESERVOIR
 IN>04:(000503)
 OUT<06:(000200)

ROUTING RESULTS	AREA (ha)	QPEAK (cms)	TPEAK (hrs)	R.V. (mm)	STORAGE (ha.m.)
INFLOW >04: (000503)	11.91	.943	12.000	47.448	.000
OUTFLOW <06: (000200)	11.91	.075	16.267	47.448	.076
					.4277E+00
					.211
					.1000E-02
					.221
					.2496E+00
					.000
					.2600E+00
					.000
					.0000E+00

PEAK FLOW REDUCTION [Qout/Qin](%) = 7.971
 TIME SHIFT OF PEAK FLOW (min) = 256.00
 MAXIMUM STORAGE USED (ha.m.) = .2874E+00

008:0009

 008:0002
 008:0002
 008:0002
 008:0002
 008:0002
 008:0002
 008:0002

008:0002-----
 5.25 1.020 11.25 6.130 17.25 1.150 23.25 .770
 5.50 1.020 11.50 6.130 17.50 1.150 23.50 .770
 5.75 1.020 11.75 6.130 17.75 1.150 23.75 .770
 6.00 1.020 12.00 70.530 18.00 1.150 24.00 .770
 008:0002-----
 ** END OF RUN : 8

 * SITE 772 WINSTON CHURCHILL*

 * PAVED AREAS AND LANDSCAPED AREAS

009:0002-----
 ** Project Name: 772 Winston Churchill Blvd., Oakville
 ** Project Number: 2256
 ** Date : DECEMBER 2022
 ** Modeller : FP
 ** Company : a.m. candaras associates inc.
 ** License # : 3813174
 ** Revision : C

009:0002-----
 ** Project Name: 772 Winston Churchill Blvd., Oakville
 ** Project Number: 2256
 ** Date : DECEMBER 2022
 ** Modeller : FP
 ** Company : a.m. candaras associates inc.
 ** License # : 3813174
 ** Revision : C

009:0002-----
 ** Project Name: 772 Winston Churchill Blvd., Oakville
 ** Project Number: 2256
 ** Date : DECEMBER 2022
 ** Modeller : FP
 ** Company : a.m. candaras associates inc.
 ** License # : 3813174
 ** Revision : C

009:0002-----

TIME	RAIN	TIME	RAIN	TIME	RAIN	TIME	RAIN	TIME	RAIN
hrs	mm/hr	hrs	mm/hr	hrs	mm/hr	hrs	mm/hr	hrs	mm/hr
0.25	.700	6.25	1.280	12.25	9.200	18.25	1.150	18.25	1.150
.50	.700	6.50	1.280	12.50	9.200	18.50	1.150	18.50	1.150
.75	.700	6.75	1.280	12.75	4.730	18.75	1.150	18.75	1.150
1.00	.700	7.00	1.280	13.00	4.730	19.00	1.150	19.00	1.150
1.25	.700	7.25	1.280	13.25	.890	19.25	1.150	19.25	1.150
1.50	.700	7.50	1.280	13.50	.890	19.50	1.150	19.50	1.150
1.75	.700	7.75	1.280	13.75	5.240	19.75	1.150	19.75	1.150
2.00	.700	8.00	1.280	14.00	5.240	20.00	1.150	20.00	1.150
2.25	.830	8.25	1.720	14.25	1.920	20.25	.770	20.25	.770
2.50	.830	8.50	1.720	14.50	1.920	20.50	.770	20.50	.770
2.75	.830	8.75	1.720	14.75	1.920	20.75	.770	20.75	.770
3.00	.830	9.00	1.720	15.00	1.920	21.00	.770	21.00	.770
3.25	.830	9.25	2.040	15.25	1.920	21.25	.770	21.25	.770
3.50	.830	9.50	2.040	15.50	1.920	21.50	.770	21.50	.770
3.75	.830	9.75	2.300	15.75	1.920	21.75	.770	21.75	.770
4.00	.830	10.00	2.300	16.00	1.920	22.00	.770	22.00	.770
4.25	1.020	10.25	2.940	16.25	1.150	22.25	.770	22.25	.770
4.50	1.020	10.50	2.940	16.50	1.150	22.50	.770	22.50	.770
4.75	1.020	10.75	3.960	16.75	1.150	22.75	.770	22.75	.770
5.00	1.020	11.00	3.960	17.00	1.150	23.00	.770	23.00	.770

009:0002-----
 ** Project Name: 772 Winston Churchill Blvd., Oakville
 ** Project Number: 2256
 ** Date : DECEMBER 2022
 ** Modeller : FP
 ** Company : a.m. candaras associates inc.
 ** License # : 3813174
 ** Revision : C

009:0002-----
 ** Project Name: 772 Winston Churchill Blvd., Oakville
 ** Project Number: 2256
 ** Date : DECEMBER 2022
 ** Modeller : FP
 ** Company : a.m. candaras associates inc.
 ** License # : 3813174
 ** Revision : C

009:0002-----
 ** Project Name: 772 Winston Churchill Blvd., Oakville
 ** Project Number: 2256
 ** Date : DECEMBER 2022
 ** Modeller : FP
 ** Company : a.m. candaras associates inc.
 ** License # : 3813174
 ** Revision : C

009:0002-----
 ** Project Name: 772 Winston Churchill Blvd., Oakville
 ** Project Number: 2256
 ** Date : DECEMBER 2022
 ** Modeller : FP
 ** Company : a.m. candaras associates inc.
 ** License # : 3813174
 ** Revision : C

009:0002-----

CALIB STANDHYD	DT=	Area	(ha)	Total Imp(%)	Dir. Conn.(%)
01:001	1.00	5.90	90.00	90.00	90.00
IMPERVIOUS PERVIOUS (i)					
Surface Area	(ha)	5.31			.59
Dep. Storage	(mm)	2.00			5.00
Average Slope	(%)	1.00			2.00
Length	(m)	30.00			40.00
Mannings n		.013			.250
Max.eff.Inten.(mm/hr)		70.53			26.86
Storage Coeff.(min)		1.00			13.00
Unit Hyd. Tpeak (min)		1.43 (ii)			13.37 (ii)
Unit Hyd. peak (cms)		.86			13.00
PEAK FLOW (cms)		1.04			.09
TIME TO PEAK (hrs)		12.00			.03
RUNOFF VOLUME (mm)		61.89			12.12
TOTAL RAINFALL (mm)		63.89			20.67
RUNOFF COEFFICIENT		.97			63.89
TOTALS					
					1.063 (iii)
					12.000
					57.770
					63.892
					.904

(i) CN PROCEDURE SELECTED FOR PERVIOUS LOSSES:
 CN* = 70.0 Ia = Dep. Storage (Above)
 (ii) TIME STEP (DT) SHOULD BE SMALLER OR EQUAL THAN THE STORAGE COEFFICIENT.
 (iii) PEAK FLOW DOES NOT INCLUDE BASEFLOW IF ANY.

009:0004-----

CALIB STANDHYD	DT=	Area	(ha)	Total Imp(%)	Dir. Conn.(%)
02:002	1.00	6.01	99.00	99.00	99.00
IMPERVIOUS PERVIOUS (i)					
Surface Area	(ha)	5.95			.06
Dep. Storage	(mm)	2.00			5.00
Average Slope	(%)	1.00			2.00
Length	(m)	30.00			40.00
Mannings n		.013			.250
Max.eff.Inten.(mm/hr)		70.53			26.86
Storage Coeff.(min)		1.00			13.00
Unit Hyd. Tpeak (min)		1.43 (ii)			13.37 (ii)
Unit Hyd. peak (min)		1.00			13.00

Unit Hyd. peak (cms) = .86
 PEAK FLOW (cms) = 1.17
 TIME TO PEAK (hrs) = 12.00
 RUNOFF VOLUME (mm) = 61.89
 TOTAL RAINFALL (mm) = 63.89
 RUNOFF COEFFICIENT = .97

- (i) CN PROCEDURE SELECTED FOR PERVIOUS LOSSES:
 CN* = 70.0 Ia = Dep. Storage (Above)
- (ii) TIME STEP (DT) SHOULD BE SMALLER OR EQUAL THAN THE STORAGE COEFFICIENT.
- (iii) PEAK FLOW DOES NOT INCLUDE BASEFLOW IF ANY.

009:0005
 * CONTROLLED FLOW ROOF DRAINS - BLDG A & B

Requested routing time step = 1.0 min.

ROUTE RESERVOIR		OUTFLOW STORAGE TABLE		STORAGE	
IN>02: (002)	OUT<03: (000200)	(cms)	(ha.m.)	(cms)	(ha.m.)
		.000	.0000E+00	.232	.5062E+00
		.140	.2058E+00	2.000	.5070E+00
		.186	.3560E+00	.000	.0000E+00

ROUTING RESULTS		AREA	QPEAK	TPEAK	R.V.
		(ha)	(cms)	(hrs)	(mm)
INFLOW >02: (002)		6.01	1.168	12.000	61.480
OUTFLOW <03: (000200)		6.01	.130	12.517	61.479
OVERFLOW <07: (001007)		.00	.000	.000	.000

TOTAL NUMBER OF SIMULATED OVERFLOWS = 0
 CUMULATIVE TIME OF OVERFLOWS (hours) = .00
 PERCENTAGE OF TIME OVERFLOWING (%) = .00

PEAK FLOW REDUCTION [Qout/Qin] (%) = 11.127
 TIME SHIFT OF PEAK FLOW (min) = 31.00
 MAXIMUM STORAGE USED (ha.m.) = .1909E+00

ROUTE RESERVOIR		OUTFLOW STORAGE TABLE		STORAGE	
IN>04: (000503)	OUT<06: (000200)	(cms)	(ha.m.)	(cms)	(ha.m.)
ID1 01:001		5.90	1.063	12.00	57.77
+ID2 03:000200		6.01	.130	12.52	61.48
+ID3 07:001007		.00	.000	.00	.00
*****DRY**					
SUM 04:000503		11.91	1.184	12.00	59.64

NOTE: PEAK FLOWS DO NOT INCLUDE BASEFLOWS IF ANY.

009:0007

 *STORMWATER MANAGEMENT
 *BELOW GROUND STORAGE SYSTEM

*BOTTOM ELEV:90.0m ; TOP ELEV 92.06
 *EROS/EXT ELEV 91.10, EROS VOL 2,581m3
 *ORIFICE 1: ELEV 89.15, 63mm ORIFICE
 *ORIFICE 2: ELEV 91.80, 260mm DIA.
 *STORMTECH CHAMBERS MC-4500 - 1,837m3
 *SURFACE DRY POND AREA - 3,405m3
 *SURFACE STORAGE - 0.25m DEEP - 820m3
 *TOTAL VOLUME: 5,077 m3

Requested routing time step = 1.0 min.

ROUTE RESERVOIR		OUTFLOW STORAGE TABLE		STORAGE	
IN>04: (000503)	OUT<05: (000201)	(cms)	(ha.m.)	(cms)	(ha.m.)
		.000	.0000E+00	.014	.2233E+00
		.008	.7000E-02	.014	.2366E+00
		.009	.1430E-01	.014	.2496E+00
		.010	.4160E-01	.014	.2629E+00
		.010	.7150E-01	.054	.2764E+00
		.011	.1023E+00	.068	.2841E+00
		.012	.1309E+00	.128	.3242E+00
		.012	.1468E+00	.170	.3792E+00
		.012	.1626E+00	.204	.4455E+00
		.013	.1937E+00	.219	.5653E+00

ROUTING RESULTS		AREA	QPEAK	TPEAK	R.V.
		(ha)	(cms)	(hrs)	(mm)
INFLOW >04: (000503)		11.91	1.184	12.000	59.641
OUTFLOW <05: (000201)		11.91	.129	14.583	59.642

PEAK FLOW REDUCTION [Qout/Qin] (%) = 10.918
 TIME SHIFT OF PEAK FLOW (min) = 155.00
 MAXIMUM STORAGE USED (ha.m.) = .3262E+00

009:0008

*PRINT HYD ID = 5 # OF PCYCLES=1
 * MODEL SIMULATION OF THE THREE STAGES OF PUMPING
 * P1=14 l/s, P1+P2=76l/s, P1+P2+P3=221 l/s

Requested routing time step = 1.0 min.

ROUTE RESERVOIR		OUTFLOW STORAGE TABLE		STORAGE	
IN>04: (000503)	OUT<06: (000200)	(cms)	(ha.m.)	(cms)	(ha.m.)
		.000	.0000E+00	.076	.4277E+00
		.012	.1000E-02	.211	.4287E+00
		.014	.2496E+00	.221	.5653E+00
		.075	.2600E+00	.000	.0000E+00

ROUTING RESULTS		AREA	QPEAK	TPEAK	R.V.
		(ha)	(cms)	(hrs)	(mm)
INFLOW >04: (000503)		11.91	1.184	12.000	59.641
OUTFLOW <06: (000200)		11.91	.076	17.817	59.642

PEAK FLOW REDUCTION [Qout/Qin] (%) = 6.390
 TIME SHIFT OF PEAK FLOW (min) = 349.00
 MAXIMUM STORAGE USED (ha.m.) = .3686E+00

009:0009-----

009:0002-----
009:0002-----
009:0002-----
009:0002-----
009:0002-----
009:0002-----
009:0002-----
009:0002-----
009:0002-----
009:0002-----
** END OF RUN : 9

START | Project dir.: C:\PROGRA-1\SWHYMO\Projects\2256\
Rainfall dir.: C:\PROGRA-1\SWHYMO\Projects\2256\
TZERO = .00 hrs on 0
METOUT= 2 (output = METRIC)
NRUN = 010
NSTORM= 1
1=10Y24HS.STM

010:0002-----

Project Name: 772 Winston Churchill Blvd., Oakville
Project Number: 2256
Date : DECEMBER 2022
Modeller : FP
Company : a.m. candaras associates inc.
License # : 3813174
Revision : C

Table with columns: TIME, RAIN, mm/hr, TIME, RAIN, mm/hr, TIME, RAIN, mm/hr. Includes a summary row: READ STORM Total= 72.94 mm

1.50 .800 7.50 1.460 13.50 1.020 19.50 1.310
1.75 .800 7.75 1.460 13.75 5.980 19.75 1.310
2.00 .800 8.00 1.460 14.00 5.980 20.00 1.310
2.25 .950 8.25 1.970 14.25 2.190 20.25 .880
2.50 .950 8.50 1.970 14.50 2.190 20.50 .880
2.75 .950 8.75 1.970 14.75 2.190 20.75 .880
3.00 .950 9.00 1.970 15.00 2.190 21.00 .880
3.25 .950 9.25 2.330 15.25 2.190 21.25 .880
3.50 .950 9.50 2.330 15.50 2.190 21.50 .880
3.75 .950 9.75 2.630 15.75 2.190 21.75 .880
4.00 .950 10.00 2.630 16.00 2.190 22.00 .880
4.25 1.170 10.25 3.350 16.25 1.310 22.25 .880
4.50 1.170 10.50 3.350 16.50 1.310 22.50 .880
4.75 1.170 10.75 4.520 16.75 1.310 22.75 .880
5.00 1.170 11.00 4.520 17.00 1.310 23.00 .880
5.25 1.170 11.25 7.000 17.25 1.310 23.25 .880
5.50 1.170 11.50 7.000 17.50 1.310 23.50 .880
5.75 1.170 11.75 30.330 17.75 1.310 23.75 .880
6.00 1.170 12.00 80.500 18.00 1.310 24.00 .880

010:0003-----

**SITE 772 WINSTON CHURCHILL*

* PAVED AREAS AND LANDSCAPED AREAS
CALIB STANDHYD Area (ha)= 5.90 Dir. Conn.(%)= 90.00
01:001 DT= 1.00 Total Imp(%)= 90.00

IMPERVIOUS PERVIOUS (i)
Surface Area (ha)= 5.31 .59
Dep. Storage (mm)= 2.00 5.00
Average Slope (%)= 1.00 2.00
Length (m)= 30.00 40.00
Mannings n = .013 .250
Max.eff.Inten.(mm/hr)= 80.50 34.46
Storage Coeff. (min)= 1.00 12.00
Unit Hyd. Tpeak (min)= 1.35 (ii) 12.16 (ii)
Unit Hyd. peak (cms)= 1.00 12.00
PEAK FLOW (cms)= 1.19 .09
TIME TO PEAK (hrs)= 12.00 12.10
RUNOFF VOLUME (mm)= 70.94 26.10
TOTAL RAINFALL (mm)= 72.94 72.94
RUNOFF COEFFICIENT = .97 .36
TOTALS
1.219 (iii)
12.000
66.459
72.942
.911

(i) CN PROCEDURE SELECTED FOR PERVIOUS LOSSES:
CN* = 70.0 Ia = Dep. Storage (Above)
(ii) TIME STEP (DT) SHOULD BE SMALLER OR EQUAL THAN THE STORAGE COEFFICIENT.
(iii) PEAK FLOW DOES NOT INCLUDE BASEFLOW IF ANY.

010:0004-----
** BUILDING AREAS WITH CONTROLLED FLOW ROOF DRAINS

```

-----
CALIB STANDHYD          Area (ha)= 6.01
02:002 DT= 1.00      Total Imp(%)= 99.00 Dir. Conn.(%)= 99.00
-----
Surface Area (ha)= 5.95 IMPERVIOUS PERVIOUS (i)
Dep. Storage (mm)= 2.00          5.06
Average Slope (%)= 1.00          5.00
Length (m)= 30.00          2.00
Mannings n = .013          40.00
Max. eff. Inten. (mm/hr)= 80.50          .250
over (min) 1.00          34.46
Storage Coeff. (min)= 1.35 (ii) 12.00          12.00
Unit Hyd. Tpeak (min)= 1.00          12.16 (ii)
Unit Hyd. peak (cms)= .89          12.00
PEAK FLOW (cms)= 1.33          .09
TIME TO PEAK (hrs)= 12.00          1.334 (iii)
RUNOFF VOLUME (mm)= 70.93          12.000
TOTAL RAINFALL (mm)= 72.94          70.493
RUNOFF COEFFICIENT = .97          72.942
          .966
    
```

(i) CN PROCEDURE SELECTED FOR PERVIOUS LOSSES:
 CN* = 70.0 Ia = Dep. Storage (Above)
 (ii) TIME STEP (DT) SHOULD BE SMALLER OR EQUAL THAN THE STORAGE COEFFICIENT.
 (iii) PEAK FLOW DOES NOT INCLUDE BASEFLOW IF ANY.

010:0005 CONTROLLED FLOW ROOF DRAINS - BLDG A & B

Requested routing time step = 1.0 min.

```

===== OUTFLOW STORAGE TABLE =====
OUTFLOW STORAGE (cms) | OUTFLOW STORAGE (ha.m.) | STORAGE (ha.m.)
.000 .0000E+00          | .000 .0000E+00          | .2233E+00
.140 .2058E+00          | .232 .5062E+00          | .2366E+00
.186 .3560E+00          | 2.000 .5070E+00        | .2496E+00
          .000          | .000 .0000E+00          | .2629E+00
          .000          | .000 .0000E+00          | .2764E+00
          .000          | .000 .0000E+00          | .2841E+00
          .000          | .000 .0000E+00          | .3242E+00
          .000          | .000 .0000E+00          | .3792E+00
          .000          | .000 .0000E+00          | .4455E+00
          .000          | .000 .0000E+00          | .5653E+00
    
```

ROUTING RESULTS

AREA (ha)	QPEAK (cms)	TPEAK (hrs)	R.V. (mm)
6.01	1.334	12.000	70.493
6.01	.144	12.517	70.493
.00	.000	.000	.000

TOTAL NUMBER OF SIMULATED OVERFLOWS = 0
 CUMULATIVE TIME OF OVERFLOWS (hours) = .00
 PERCENTAGE OF TIME OVERFLOWING (%) = .00

PEAK FLOW REDUCTION [Qout/Qin](%) = 10.803
 TIME SHIFT OF PEAK FLOW (min) = 31.00
 MAXIMUM STORAGE USED (ha.m.) = .2188E+00

```

-----
ADD HYD (000503) | ID: NHYD AREA QPEAK TPEAK R.V. DWF
(ha) (cms) (hrs) (mm) (cms)
ID1 01:001 5.90 1.219 12.00 66.46 .000
+ID2 03:000200 6.01 .144 12.52 70.49 .000
+ID3 07:001007 .00 .000 .00 .00 **DRY**
SUM 04:000503 11.91 1.357 12.00 68.49 .000
    
```

NOTE: PEAK FLOWS DO NOT INCLUDE BASEFLOWS IF ANY.

010:0007

 *STORMWATER MANAGEMENT
 *BELOW GROUND STORAGE SYSTEM
 *EROS/EXT ELEV 91.10, EROS VOL 2, 581m3
 *ORIFICE 1: ELEV 89.15, 63mm ORIFICE
 *ORIFICE 2: ELEV 91.80, 260mm DIA.
 *STORMTECH CHAMBERS MC-4500 - 1,837m3
 *SURFACE DRY POND AREA - 3,405m3
 *SURFACE STORAGE - 0.25m DEEP - 820m3
 *TOTAL VOLUME: 5,077 m3

Requested routing time step = 1.0 min.

```

===== OUTFLOW STORAGE TABLE =====
OUTFLOW STORAGE (cms) | OUTFLOW STORAGE (ha.m.) | STORAGE (ha.m.)
.000 .0000E+00          | .000 .0000E+00          | .2233E+00
.008 .7000E-02          | .009 .1430E-01          | .2366E+00
.010 .4160E-01          | .010 .7150E-01          | .2496E+00
.011 .1023E+00          | .012 .1309E+00          | .2629E+00
.012 .1309E+00          | .012 .1468E+00          | .2764E+00
.012 .1626E+00          | .013 .1937E+00          | .2841E+00
.013 .1937E+00          | .012 .1309E+00          | .3242E+00
          .000          | .012 .1468E+00          | .3792E+00
          .000          | .012 .1626E+00          | .4455E+00
          .000          | .013 .1937E+00          | .5653E+00
    
```

ROUTING RESULTS

AREA (ha)	QPEAK (cms)	TPEAK (hrs)	R.V. (mm)
11.91	1.357	12.000	68.494
11.91	.152	14.400	68.494

PEAK FLOW REDUCTION [Qout/Qin](%) = 11.206
 TIME SHIFT OF PEAK FLOW (min) = 144.00
 MAXIMUM STORAGE USED (ha.m.) = .3557E+00

010:0008

PEAK FLOW (cms) = 1.39
 TIME TO PEAK (hrs) = 12.00
 RUNOFF VOLUME (mm) = 83.24
 TOTAL RAINFALL (mm) = 85.25
 RUNOFF COEFFICIENT = .98

- (i) CN PROCEDURE SELECTED FOR PERVIOUS LOSSES:
 CN* = 70.0 Ia = Dep. Storage (Above)
- (ii) TIME STEP (DT) SHOULD BE SMALLER OR EQUAL THAN THE STORAGE COEFFICIENT.
- (iii) PEAK FLOW DOES NOT INCLUDE BASEFLOW IF ANY.

011:0004

* BUILDING AREAS WITH CONTROLLED FLOW ROOF DRAINS

CALIB STANDHYD Area (ha) = 6.01
 02:002 DT= 1.00 Total Imp(%) = 99.00 Dir. Conn.(%) = 99.00

Surface Area (ha) = 5.95
 Dep. Storage (mm) = 2.00
 Average Slope (%) = 1.00
 Length (m) = 30.00
 Mannings n = .013

Max.eff.Inten.(mm/hr) = 94.14
 over (min) = 1.00
 Storage Coeff. (min) = 1.27 (ii)
 Unit Hyd. Ipeak (min) = 1.00
 Unit Hyd. peak (cms) = .93

PEAK FLOW (cms) = 1.56
 TIME TO PEAK (hrs) = 12.08
 RUNOFF VOLUME (mm) = 83.25
 TOTAL RAINFALL (mm) = 85.25
 RUNOFF COEFFICIENT = .98

- (i) CN PROCEDURE SELECTED FOR PERVIOUS LOSSES:
 CN* = 70.0 Ia = Dep. Storage (Above)
- (ii) TIME STEP (DT) SHOULD BE SMALLER OR EQUAL THAN THE STORAGE COEFFICIENT.
- (iii) PEAK FLOW DOES NOT INCLUDE BASEFLOW IF ANY.

011:0005

* CONTROLLED FLOW ROOF DRAINS - BLDG A & B

ROUTE RESERVOIR IN>02: (002)

Requested routing time step = 1.0 min.
 ===== OUTFLOW STORAGE TABLE =====
 OUTFLOW STORAGE (cms) | OUTFLOW STORAGE (ha.m.) | STORAGE (ha.m.)
 .000 .000E+00 .014 .233E+00
 .008 .700E-02 .014 .236E+00
 .009 .143E-01 .014 .249E+00
 .010 .416E-01 .014 .262E+00
 .010 .715E-01 .054 .276E+00
 .011 .102E+00 .068 .284E+00
 .012 .130E+00 .128 .324E+00
 .012 .146E+00 .170 .379E+00
 .012 .162E+00 .204 .445E+00
 .013 .193E+00 .219 .565E+00

ROUTING RESULTS AREA QPEAK TPEAK R.V.

INFLOW >02: (002) (ha) (cms) (hrs) (mm)
 1.561 1.561 12.000 82.756
 OUTFLOW<03: (000200) 6.01 .156 12.517 82.755
 OVERFLOW<07: (001007) .00 .000 .000 .000

TOTAL NUMBER OF SIMULATED OVERFLOWS = 0
 CUMULATIVE TIME OF OVERFLOWS (hours) = .00
 PERCENTAGE OF TIME OVERFLOWING (%) = .00

PEAK FLOW REDUCTION [Qout/Qin](%) = 10.015
 TIME SHIFT OF PEAK FLOW (min) = 31.00
 MAXIMUM STORAGE USED (ha.m.) = .2587E+00

011:0006

ADD HYD (000503) | ID: NHYD AREA QPEAK TPEAK R.V. DWF
 (ha) (cms) (hrs) (mm) (cms)
 ID1 01:001 5.90 1.434 12.00 78.33 .000
 +ID2 03:000200 6.01 .156 12.52 82.76 .000
 +ID3 07:001007 .00 .000 .000 .000 **DRY**
 =====
 SUM 04:000503 11.91 1.585 12.00 80.56 .000

NOTE: PEAK FLOWS DO NOT INCLUDE BASEFLOWS IF ANY.

011:0007

 *STORMWATER MANAGEMENT*****
 *BELOW GROUND STORAGE SYSTEM
 *BOTTOM ELEV:90.0m ; TOP ELEV 92.06
 *EROS/EXT ELEV 91.10, EROS VOL.2,581m3
 *ORIFICE 1: ELEV 89.15, 63mm ORIFICE
 *ORIFICE 2: ELEV 91.80, 260mm DIA.
 *STORMTECH CHAMBERS MC-4500 - 1,837m3
 *SURFACE DRY POND AREA - 3,405m3
 *SURFACE STORAGE - 0.25m DEEP - 82.0m3
 *TOTAL VOLUME: 5,077 m3

ROUTE RESERVOIR IN>04: (000503) Requested routing time step = 1.0 min.

OUT<05: (000201) ===== OUTFLOW STORAGE TABLE =====
 OUTFLOW STORAGE (cms) | OUTFLOW STORAGE (ha.m.) | STORAGE (ha.m.)
 .000 .000E+00 .014 .233E+00
 .008 .700E-02 .014 .236E+00
 .009 .143E-01 .014 .249E+00
 .010 .416E-01 .014 .262E+00
 .010 .715E-01 .054 .276E+00
 .011 .102E+00 .068 .284E+00
 .012 .130E+00 .128 .324E+00
 .012 .146E+00 .170 .379E+00
 .012 .162E+00 .204 .445E+00
 .013 .193E+00 .219 .565E+00

ROUTING RESULTS AREA QPEAK TPEAK R.V.

INFLOW >04: (000503) 11.91 1.585 12.000 80.562
 OUTFLOW<05: (000201) 11.91 .182 14.400 80.562

PEAK FLOW REDUCTION [Qout/Qin](%) = 11.467
 TIME SHIFT OF PEAK FLOW (min) = 144.00
 MAXIMUM STORAGE USED (ha.m.) = .4018E+00

011:0008

*PRINT HYD ID = 5 # OF PCYCLES=1
 * MODEL SIMULATION OF THE THREE STAGES OF PUMPING
 * P1=14 l/s, P1+P2=76l/s, P1+P2+P3=221 l/s

Requested routing time step = 1.0 min.

=====		OUTFLOW STORAGE TABLE		=====	
OUTFLOW	STORAGE	OUTFLOW	STORAGE	OUTFLOW	STORAGE
(cms)	(ha.m.)	(cms)	(ha.m.)	(cms)	(ha.m.)
.000	.0000E+00	.076	.4277E+00		
.012	.1000E-02	.211	.4287E+00		
.014	.2496E+00	.221	.5653E+00		
.075	.2600E+00	.000	.0000E+00		

ROUTING RESULTS

INFLOW >04: (000503) 11.91 1.585 12.000 80.562
 OUTFLOW<06: (000200) 11.91 .211 14.017 80.562

PEAK FLOW REDUCTION [Qout/Qin](%) = 13.347
 TIME SHIFT OF PEAK FLOW (min) = 121.00
 MAXIMUM STORAGE USED (ha.m.) = .4353E+00

011:0009

011:0002

011:0002

011:0002

011:0002

011:0002

011:0002

011:0002

011:0002

011:0002

011:0002

011:0002

011:0002

011:0002

011:0002

011:0002

011:0002

 | START | Project dir.: C:\PROGRA-1\SWMHYMO\Projects\2256\
 |-----| Rainfall dir.: C:\PROGRA-1\SWMHYMO\Projects\2256\
 |-----|

TZERO = .00 hrs on
 METOUT= 2 (output = METRIC)
 NRUN = 012
 NSTORM= 1
 # 1=50Y24HS.STM

012:0002

** Project Name: 772 Winston Churchill Blvd., Oakville
 ** Project Number: 2256
 ** Date : DECEMBER 2022
 ** Modeller : FP
 ** Company : a.m. candaras associates inc.
 ** License # : 3813174
 ** Revision : C

012:0002

READ STORM
 Ptotal= 92.76 mm

Filename: C:\PROGRA-1\SWMHYMO\Projects\2256\50Y24H
 Comments: * 100 YEAR SCS 24hr STORM, 15 min TIME S

TIME	RAIN	TIME	RAIN	TIME	RAIN
hrs	mm/hr	hrs	mm/hr	hrs	mm/hr
.25	1.020	6.25	1.860	12.25	13.360
.50	1.020	6.50	1.860	12.50	13.360
.75	1.020	6.75	1.860	12.75	6.860
1.00	1.020	7.00	1.860	13.00	6.860
1.25	1.020	7.25	1.860	13.25	1.300
1.50	1.020	7.50	1.860	13.50	1.300
1.75	1.020	7.75	1.860	13.75	7.610
2.00	1.020	8.00	1.860	14.00	7.610
2.25	1.210	8.25	2.500	14.25	2.780
2.50	1.210	8.50	2.500	14.50	2.780
2.75	1.210	8.75	2.500	14.75	2.780
3.00	1.210	9.00	2.500	15.00	2.780
3.25	1.210	9.25	2.970	15.25	2.780
3.50	1.210	9.50	2.970	15.50	2.780
3.75	1.210	9.75	3.340	15.75	2.780
4.00	1.210	10.00	3.340	16.00	2.780
4.25	1.480	10.25	4.270	16.25	1.670
4.50	1.480	10.50	4.270	16.50	1.670
4.75	1.480	10.75	5.750	16.75	1.670
5.00	1.480	11.00	5.750	17.00	1.670
5.25	1.480	11.25	8.910	17.25	1.670
5.50	1.480	11.50	8.910	17.50	1.670
5.75	1.480	11.75	38.590	17.75	1.670
6.00	1.480	12.00	102.410	18.00	1.670

012:0003

 SITE 772 WINSTON CHURCHILL

* PAVED AREAS AND LANDSCAPED AREAS

CALIB STANDHYD DT= 1.00 | Area (ha)= 5.90 | Dir. Conn. (%) = 90.00

Surface Area (ha) = 5.31 | IMPERVIOUS | PERVIOUS (i) | *TOTALS*

Dep. Storage (mm) = 2.00 | 5.00 | 5.00 | 1.567 (iii)

Average Slope (%) = 1.00 | 2.00 | 2.00 | 12.000

Length (m) = 30.00 | 40.00 | 40.00 | 85.596

Mannings n = .013 | .250 | .250 | 92.755

Max. eff. Inten. (mm/hr) = 102.41 | 52.93 | 52.93 | .923

Storage Coeff. (min) = 1.00 | 10.00 | 10.00 | .42

Unit Hyd. Tpeak (min) = 1.23 (ii) | 10.33 (ii) | 10.33 (ii) | .06

Unit Hyd. peak (cms) = 1.00 | 10.00 | 10.00 | 12.07

PEAK FLOW (cms) = 1.51 | .95 | .95 | 90.75

TIME TO PEAK (hrs) = 12.00 | .11 | .11 | 39.16

RUNOFF VOLUME (mm) = 90.75 | .42 | .42 | 92.76

TOTAL RAINFALL (mm) = 92.76 | .98 | .98 | RUNOFF COEFFICIENT = .98

(i) CN PROCEDURE SELECTED FOR PERVIOUS LOSSES:
 CN* = 70.0 Ia = Dep. Storage (Above)
 (ii) TIME STEP (DT) SHOULD BE SMALLER OR EQUAL THAN THE STORAGE COEFFICIENT.
 (iii) PEAK FLOW DOES NOT INCLUDE BASEFLOW IF ANY.

012:0004

* BUILDING AREAS WITH CONTROLLED FLOW ROOF DRAINS

CALIB STANDHYD DT= 1.00 | Area (ha)= 6.01 | Dir. Conn. (%) = 99.00

Surface Area (ha) = 5.95 | IMPERVIOUS | PERVIOUS (i) | *TOTALS*

Dep. Storage (mm) = 2.00 | 5.00 | 5.00 | 1.69 (iii)

Average Slope (%) = 1.00 | 2.00 | 2.00 | 12.000

Length (m) = 30.00 | 40.00 | 40.00 | 90.239

Mannings n = .013 | .250 | .250 | 92.755

Max. eff. Inten. (mm/hr) = 102.41 | 52.93 | 52.93 | .973

Storage Coeff. (min) = 1.00 | 10.00 | 10.00 | .42

Unit Hyd. Tpeak (min) = 1.23 (ii) | 10.33 (ii) | 10.33 (ii) | .01

Unit Hyd. peak (cms) = 1.00 | 10.00 | 10.00 | 12.07

PEAK FLOW (cms) = 1.69 | .95 | .95 | 90.75

TIME TO PEAK (hrs) = 12.00 | .11 | .11 | 39.16

RUNOFF VOLUME (mm) = 90.75 | .42 | .42 | 92.76

TOTAL RAINFALL (mm) = 92.76 | .98 | .98 | RUNOFF COEFFICIENT = .98

(i) CN PROCEDURE SELECTED FOR PERVIOUS LOSSES:

CN* = 70.0 Ia = Dep. Storage (Above)
 (ii) TIME STEP (DT) SHOULD BE SMALLER OR EQUAL THAN THE STORAGE COEFFICIENT.
 (iii) PEAK FLOW DOES NOT INCLUDE BASEFLOW IF ANY.

012:0005

* CONTROLLED FLOW ROOF DRAINS - BLDG A & B

Requested routing time step = 1.0 min.

ROUTE RESERVOIR | IN>02: (002) | OUT<03: (000200) |

OUTFLOW (cms)	STORAGE (ha.m.)	OUTFLOW (cms)	STORAGE (ha.m.)
.000	.0000E+00	.232	.5062E+00
.140	.2058E+00	2.000	.5070E+00
.186	.3560E+00	.000	.0000E+00

ROUTING RESULTS

INFLOW >02: (002)	AREA (ha)	QPEAK (cms)	TPEAK (hrs)	R.V. (mm)
OUTFLOW <03: (000200)	6.01	1.698	12.000	90.239
OVERFLOW <07: (001007)	.00	.164	12.517	90.239
	.00	.000	.000	.000

TOTAL NUMBER OF SIMULATED OVERFLOWS = 0

CUMULATIVE TIME OF OVERFLOWS (hours) = .00

PERCENTAGE OF TIME OVERFLOWING (%) = .00

PEAK FLOW REDUCTION [Qout/Qin] (%) = 9.641

TIME SHIFT OF PEAK FLOW (min) = 31.00

MAXIMUM STORAGE USED (ha.m.) = .2830E+00

012:0006

* ADD HYD (000503) | ID: NHYD

ID	AREA (ha)	QPEAK (cms)	TPEAK (hrs)	R.V. (mm)	DWF (cms)
ID1 01:001	5.90	1.567	12.00	85.60	.000
+ID2 03:000200	6.01	.164	12.52	90.24	.000
+ID3 07:001007	.00	.000	.00	.00	.000
SUM 04:000503	11.91	1.724	12.00	87.94	.000

NOTE: PEAK FLOWS DO NOT INCLUDE BASEFLOWS IF ANY.

012:0007

* STORMWATER MANAGEMENT

* BELOW GROUND STORAGE SYSTEM

* BOTTOM ELEV: 90.0m ; TOP ELEV 92.06

* EROS/EXT ELEV 91.10, EROS VOL 2, 581m3

* ORIFICE 1: ELEV 89.15, 63mm ORIFICE

* ORIFICE 2: ELEV 91.80, 260mm DIA.

* STORMTECH CHAMBERS MC-4500 - 1, 837m3

* SURFACE DRY POND AREA - 3, 405m3

* SURFACE STORAGE - 0.25m DEEP - 820m3

* TOTAL VOLUME: 5, 077 m3

Requested routing time step = 1.0 min.

OUTFLOW (cms)	STORAGE (ha.m.)	OUTFLOW (cms)	STORAGE (ha.m.)
.000	.0000E+00	.014	.2233E+00
.008	.7000E-02	.014	.2366E+00
.009	.1430E-01	.014	.2496E+00
.010	.4160E-01	.014	.2629E+00
.010	.7150E-01	.054	.2764E+00
.011	.1023E+00	.068	.2841E+00
.012	.1309E+00	.128	.3242E+00
.012	.1468E+00	.170	.3792E+00
.012	.1626E+00	.204	.4455E+00
.013	.1937E+00	.219	.5653E+00

ROUTING RESULTS

AREA (ha)	QPEAK (cms)	TPEAK (hrs)	R.V. (mm)
11.91	1.724	12.000	87.938
11.91	.197	14.167	87.938

PEAK FLOW REDUCTION [Qout/Qin](%) = 11.445
 TIME SHIFT OF PEAK FLOW (min) = 130.00
 MAXIMUM STORAGE USED (ha.m.) = .4327E+00

012:0008
 *PRINT HYD ID = 5 # OF PCYCLES=1
 * MODEL SIMULATION OF THE THREE STAGES OF PUMPING
 * P1=14 l/s, P1+P2=761/s, P1+P2+P3=221 l/s

Requested routing time step = 1.0 min.

OUTFLOW (cms)	STORAGE (ha.m.)	OUTFLOW (cms)	STORAGE (ha.m.)
.000	.0000E+00	.076	.4277E+00
.012	.1000E-02	.211	.4287E+00
.014	.2496E+00	.221	.5653E+00
.075	.2600E+00	.000	.0000E+00

ROUTING RESULTS

AREA (ha)	QPEAK (cms)	TPEAK (hrs)	R.V. (mm)
11.91	1.724	12.000	87.938
11.91	.212	14.033	87.938

PEAK FLOW REDUCTION [Qout/Qin](%) = 12.290
 TIME SHIFT OF PEAK FLOW (min) = 122.00
 MAXIMUM STORAGE USED (ha.m.) = .4400E+00

012:0009

012:0002
 012:0002
 012:0002
 012:0002
 012:0002
 012:0002
 012:0002
 012:0002
 012:0002
 012:0002
 012:0002

** END OF RUN : 12

 | START | Project dir.: C:\PROGRA-1\SMHYMO\Projects\2256\
Rainfall dir.: C:\PROGRA-1\SMHYMO\Projects\2256\
 TZERO = .00 hrs on
 METOUT= 2 (output = METRIC)
 NRUN = 013
 NSTORM= 1
 # 1=100Y24HS.STM

013:0002
 #*****
 ** Project Name: 772 Winston Churchill Blvd., Oakville
 ** Project Number: 2256
 ** Date : DECEMBER 2022
 ** Modeler : Fp
 ** Company : a.m. candaras associates inc.
 ** License # : 3813174
 ** Revision : C
 #*****

013:0002
 *
 |-----|
 | READ STORM | Filename: C:\PROGRA-1\SMHYMO\Projects\2256\100Y24
 | Ptotal= 103.37 mm | Comments: * 100 YEAR SCS 24hr STORM, 15 min TIME S
 |-----|

TIME hrs	RAIN mm/hr	TIME hrs	RAIN mm/hr	TIME hrs	RAIN mm/hr
.25	1.140	6.25	2.070	12.25	14.890
.50	1.140	6.50	2.070	12.50	14.890
.75	1.140	6.75	2.070	12.75	7.650
1.00	1.140	7.00	2.070	13.00	7.650
1.25	1.140	7.25	2.070	13.25	1.450
1.50	1.140	7.50	2.070	13.50	1.450
1.75	1.140	7.75	2.070	13.75	8.480
2.00	1.140	8.00	2.070	14.00	8.480

2.25	1.340	8.25	2.790	14.25	3.100	20.25	1.240
2.50	1.340	8.50	2.790	14.50	3.100	20.50	1.240
2.75	1.340	8.75	2.790	14.75	3.100	20.75	1.240
3.00	1.340	9.00	2.790	15.00	3.100	21.00	1.240
3.25	1.340	9.25	3.310	15.25	3.100	21.25	1.240
3.50	1.340	9.50	3.310	15.50	3.100	21.50	1.240
3.75	1.340	9.75	3.720	15.75	3.100	21.75	1.240
4.00	1.340	10.00	3.720	16.00	3.100	22.00	1.240
4.25	1.650	10.25	4.760	16.25	1.860	22.25	1.240
4.50	1.650	10.50	4.760	16.50	1.860	22.50	1.240
4.75	1.650	10.75	6.410	16.75	1.860	22.75	1.240
5.00	1.650	11.00	6.410	17.00	1.860	23.00	1.240
5.25	1.650	11.25	9.920	17.25	1.860	23.25	1.240
5.50	1.650	11.50	9.920	17.50	1.860	23.50	1.240
5.75	1.650	11.75	43.010	17.75	1.860	23.75	1.240
6.00	1.650	12.00	114.144	18.00	1.860	24.00	1.240

013:0003-----

 SITE 772 WINSTON CHURCHILL

* PAVED AREAS AND LANDSCAPED AREAS

CALIB STANDHYD	Area	(ha)=	5.90	Dir. Conn. (%)=	90.00	
01:001	DT=	1.00	Total Imp(%)=	90.00	Dir. Conn. (%)=	90.00

Surface Area	(ha)=	5.31	IMPERVIOUS	PERVIOUS (i)	
Dep. Storage	(mm)=	2.00			
Average Slope	(%)=	1.00			
Length	(m)=	30.00			
Mannings n	=	.013			
Max.eff.Inten.(mm/hr)	=	114.14			
Storage Coeff. (min)	=	1.00			
Unit Hyd. Tpeak (min)	=	1.18 (ii)			
Unit Hyd. peak (cms)	=	1.00			
PEAK FLOW (cms)	=	1.68			
TIME TO PEAK (hrs)	=	12.00			
RUNOFF VOLUME (mm)	=	101.37			
TOTAL RAINFALL (mm)	=	103.37			
RUNOFF COEFFICIENT	=	.98			

(i) CN PROCEDURE SELECTED FOR PERVIOUS LOSSES:
 CN* = 70.0 Ia = Dep. Storage (Above)
 (ii) TIME STEP (DT) SHOULD BE SMALLER OR EQUAL
 THAN THE STORAGE COEFFICIENT.
 (iii) PEAK FLOW DOES NOT INCLUDE BASEFLOW IF ANY.

013:0004-----
 * BUILDING AREAS WITH CONTROLLED FLOW ROOF DRAINS

CALIB STANDHYD	Area	(ha)=	6.01	Dir. Conn. (%)=	99.00	
02:002	DT=	1.00	Total Imp(%)=	99.00	Dir. Conn. (%)=	99.00

Surface Area	(ha)=	5.95	IMPERVIOUS	PERVIOUS (i)	
Dep. Storage	(mm)=	2.00			
Average Slope	(%)=	1.00			
Length	(m)=	30.00			
Mannings n	=	.013			
Max.eff.Inten.(mm/hr)	=	114.14			
Storage Coeff. (min)	=	1.00			
Unit Hyd. Tpeak (min)	=	1.18 (ii)			
Unit Hyd. peak (cms)	=	1.00			
PEAK FLOW (cms)	=	1.89			
TIME TO PEAK (hrs)	=	12.00			
RUNOFF VOLUME (mm)	=	101.37			
TOTAL RAINFALL (mm)	=	103.37			
RUNOFF COEFFICIENT	=	.98			

(i) CN PROCEDURE SELECTED FOR PERVIOUS LOSSES:
 CN* = 70.0 Ia = Dep. Storage (Above)
 (ii) TIME STEP (DT) SHOULD BE SMALLER OR EQUAL
 THAN THE STORAGE COEFFICIENT.
 (iii) PEAK FLOW DOES NOT INCLUDE BASEFLOW IF ANY.

013:0005-----
 * CONTROLLED FLOW ROOF DRAINS - BLDG A & B

ROUTE RESERVOIR	Requested routing time step =	1.0 min.
IN>02:(002)		
OUT<03:(000200)		

OUTFLOW	STORAGE	OUTFLOW	STORAGE
(cms)	(ha.m.)	(cms)	(ha.m.)
.000	.0000E+00	.232	.5062E+00
.140	.2058E+00	2.000	.5070E+00
.186	.3560E+00	.000	.0000E+00

ROUTING RESULTS

AREA	QPEAK	TPEAK	R.V.
(ha)	(cms)	(hrs)	(mm)
6.01	1.894	12.000	100.827
6.01	.174	12.517	100.827
.00	.000	.000	.000

TOTAL NUMBER OF SIMULATED OVERFLOWS = 0
 CUMULATIVE TIME OF OVERFLOWS (hours) = .00
 PERCENTAGE OF TIME OVERFLOWING (%) = .00

PEAK FLOW REDUCTION [Qout/Qin] (%) = 9.206
 TIME SHIFT OF PEAK FLOW (min) = 31.00
 MAXIMUM STORAGE USED (ha.m.) = .3176E+00

013:0006-----
 * BUILDING AREAS WITH CONTROLLED FLOW ROOF DRAINS

ADD HYD (000503)	ID:	NHYD	AREA	QPEAK	TPEAK	R.V.	DWF
			(ha)	(cms)	(hrs)	(mm)	(cms)
ID1 01:001			5.90	1.753	12.00	95.91	.000

+ID2	03:000200	6.01	.174	12.52	100.83	.000
+ID3	07:001007	.00	.000	.00	.00	.000
SUM	04:000503	11.91	1.919	12.00	98.39	.000

NOTE: PEAK FLOWS DO NOT INCLUDE BASEFLOWS IF ANY.

013:0007-----

 *STORMWATER MANAGEMENT
 *BELOW GROUND STORAGE SYSTEM
 *BOTTOM ELEV:90.0m ; TOP ELEV 92.06
 *EROS/EXT ELEV 91.10, EROS VOL 2,581m3
 *ORIFICE 1: ELEV 89.15, 63mm ORIFICE
 *ORIFICE 2: ELEV 91.80, 260mm DIA.
 *STORMTECH CHAMBERS MC-4500 - 1,837m3
 *SURFACE DRY POND AREA - 3,405m3
 *SURFACE STORAGE - 0.25m DEEP - 820m3
 *TOTAL VOLUME: 5,077 m3

Requested routing time step = 1.0 min.

ROUTE RESERVOIR IN>04:(000503) OUT<05:(000201)		
OUTFLOW (cms)	OUTFLOW STORAGE (ha.m.)	OUTFLOW STORAGE TABLE (cms) (ha.m.)
.000	.000E+00	.014 .2233E+00
.008	.7000E-02	.014 .2366E+00
.009	.1430E-01	.014 .2496E+00
.010	.4160E-01	.014 .2629E+00
.010	.7150E-01	.054 .2764E+00
.011	.1023E+00	.068 .2841E+00
.012	.1309E+00	.128 .3242E+00
.012	.1468E+00	.170 .3792E+00
.012	.1626E+00	.204 .4455E+00
.013	.1937E+00	.219 .5653E+00

ROUTING RESULTS			
INFLOW >04: (000503)	AREA (ha)	OPEAK (cms)	TPEAK (hrs)
OUTFLOW<05: (000201)	11.91	1.919	12.000
	11.91	.208	14.400

PEAK FLOW REDUCTION [Qout/Qin](%) = 10.854
 TIME SHIFT OF PEAK FLOW (min) = 144.00
 MAXIMUM STORAGE USED (ha.m.) = .4827E+00

013:0008-----
 *PRINT HYD ID = 5 OF PCYCLES=1
 * MODEL SIMULATION OF THE THREE STAGES OF PUMPING
 * P1=14 l/s, P1+P2=76l/s, P1+P2+P3=221 l/s

ROUTE RESERVOIR IN>04:(000503) OUT<06:(000200)		
OUTFLOW (cms)	OUTFLOW STORAGE (ha.m.)	OUTFLOW STORAGE TABLE (cms) (ha.m.)
.000	.0000E+00	.076 .4277E+00
.012	.1000E-02	.211 .4287E+00

Requested routing time step = 1.0 min.

ROUTING RESULTS			
INFLOW >04: (000503)	AREA (ha)	QPEAK (cms)	TPEAK (hrs)
OUTFLOW<06: (000200)	11.91	1.919	12.000
	11.91	.215	14.133

PEAK FLOW REDUCTION [Qout/Qin](%) = 11.186
 TIME SHIFT OF PEAK FLOW (min) = 128.00
 MAXIMUM STORAGE USED (ha.m.) = .4788E+00

013:0009-----

013:0002-----

013:0002-----

013:0002-----

013:0002-----

013:0002-----

013:0002-----

013:0002-----

013:0002-----

013:0002-----

013:0002-----

013:0002-----

013:0002-----

013:0002-----

013:0002-----

013:0002-----

013:0002-----

013:0002-----

013:0002-----

013:0002-----

013:0002-----

013:0002-----

013:0002-----

013:0002-----

013:0002-----

```

=====
SSSSS W W M M H H Y Y M M O O O 999 999
S W W MM MM H H Y Y MM MM O O 9 9 9 9
SSSS W W M M H H H H Y Y M M O O # 9 9 9 9 Ver. 4.02
S W W M M H H Y Y M M O O 9999 9999 July 1999
SSSS W W M M H H Y Y M M O O 9 9 9 9
=====
StormWater Management Hydrologic Model
999 999 # 3813174
=====

```

```

*****
***** SWHYMO-99 Ver/4.02 *****
***** A single event and continuous hydrologic simulation model *****
***** based on the principles of HYMO and its successors *****
***** OTHYMO-83 and OTHYMO-89. *****
***** Distributed by: J.F. Sabourin and Associates Inc. *****
***** Ottawa, Ontario: (613) 727-5199 *****
***** Gatineau, Quebec: (819) 243-6858 *****
***** E-Mail: swmhyo@jfsa.Com *****
*****

```

```

+++++ Licensed user: A.M. Candaras Associates Inc. +++++
+++++ Woodbridge SERIAL#:3813174 +++++
*****
***** +++++ PROGRAM ARRAY DIMENSIONS +++++
***** Maximum value for ID numbers : 10 *****
***** Max. number of rainfall points: 15000 *****
***** Max. number of flow points : 15000 *****

```

```

***** D E T A I L E D O U T P U T *****
***** DATE: 2022-12-16 TIME: 11:17:19 RUN COUNTER: 000530 *****
***** Input filename: C:\PROGRA-1\SWHYMO\Projects\2256\2256RegC.dat *****
***** Output filename: C:\PROGRA-1\SWHYMO\Projects\2256\2256RegC.out *****
***** Summary filename: C:\PROGRA-1\SWHYMO\Projects\2256\2256RegC.sum *****
***** User comments: *****
* 1:
* 2:
* 3:

```

```

001:0001-----
# Project Name: 772 Winston Churchill Blvd., Oakville
# Project Number: 2256
# Date : DECEMBER 2022
# Modeller : FP
# Company : a.m. candaras associates inc.
# License # : 3813174
# Revision : C
#

```

```

| START | Project dir.: C:\PROGRA-1\SWHYMO\Projects\2256\
| Rainfall dir.: C:\PROGRA-1\SWHYMO\Projects\2256\
TZERO = .00 hrs on 0
METOUT= 2 (output = METRIC)
NRUN = 001
NSTORM= 1
# 1=HAZEL.STM

```

001:0002-----*

```

| READ STORM | Filename: C:\PROGRA-1\SWHYMO\Projects\2256\HAZEL.
| Ptotal= 212.00 mm | Comments: HURRICANE HAZEL STORM

```

TIME	RAIN	TIME	RAIN	TIME	RAIN	TIME	RAIN
hrs	mm/hr	hrs	mm/hr	hrs	mm/hr	hrs	mm/hr
1.00	6.000	4.00	13.000	7.00	23.000	10.00	53.000
2.00	4.000	5.00	17.000	8.00	13.000	11.00	38.000
3.00	6.000	6.00	13.000	9.00	13.000	12.00	13.000

001:0003-----

```

*****
*SITE 772 WINSTON CHURCHILL*
*****

```

* PAVED AREAS AND LANDSCAPED AREAS

```

| CALIB STANDHYD | Area (ha)= 5.90
| 01:001 DT= 1.00 | Total Imp(%)= 90.00 Dir. Conn.(%)= 90.00

```

IMPERVIOUS	PERVIOUS (i)
Surface Area (ha) = 5.31	5.59
Dep. Storage (mm) = 2.00	5.00
Average Slope (%) = 1.00	2.00
Length (m) = 30.00	40.00
Mannings n = .013	.250
Max.eff.Inten.(mm/hr) = 53.00	50.55
Storage Coeff. over (min) = 2.00	11.00
Unit Hyd. Tpeak (min) = 1.60 (ii)	10.87 (ii)
Unit Hyd. peak (cms) = 2.00	11.00
	.10

```

*TOTALS*
PEAK FLOW (cms) = .78 .864 (iii)
TIME TO PEAK (hrs) = 9.47 10.00
RUNOFF VOLUME (mm) = 210.00 172.52
TOTAL RAINFALL (mm) = 212.00 212.00
RUNOFF COEFFICIENT = .99 .81

```

```

(i) CN PROCEDURE SELECTED FOR PERVIOUS LOSSES:
CN* = 86.0 Ia = Dep. Storage (Above)
(ii) TIME STEP (DT) SHOULD BE SMALLER OR EQUAL
THAN THE STORAGE COEFFICIENT.
(iii) PEAK FLOW DOES NOT INCLUDE BASEFLOW IF ANY.

```

001:0004-----*

* BUILDING AREAS WITH CONTROLLED FLOW ROOF DRAINS

```

-----
CALIB STANDHYD      Area (ha)= 6.01
02:002 DT= 1.00 | Total Imp(%)= 99.00 Dir. Conn.(%)= 99.00
-----
Surface Area (ha) = 5.95 IMPERVIOUS PERVIOUS (i)
Dep. Storage (mm) = 2.00          .06
Average Slope (%) = 1.00          5.00
Length (m) = 30.00          40.00
Mannings n = .013          .250
Max. eff. Inten. (mm/hr) = 53.00          50.55
over (min) = 2.00          11.00
Storage Coeff. (min) = 1.60 (ii)  10.87 (ii)
Unit Hyd. Tpeak (min) = 2.00          11.00
Unit Hyd. peak (cms) = .64          .10
-----
PEAK FLOW (cms) = .88          .01
TIME TO PEAK (hrs) = 9.47          10.00
RUNOFF VOLUME (mm) = 210.00        172.53
TOTAL RAINFALL (mm) = 212.00        212.00
RUNOFF COEFFICIENT = .99          .81
-----

```

```

(i) CN PROCEDURE SELECTED FOR PERVIOUS LOSSES:
CN* = 86.0 Ia = Dep. Storage (Above)
(ii) TIME STEP (DT) SHOULD BE SMALLER OR EQUAL
THAN THE STORAGE COEFFICIENT.
(iii) PEAK FLOW DOES NOT INCLUDE BASEFLOW IF ANY.
-----
001:0005
* CONTROLLED FLOW ROOF DRAINS - BLDG A & B
* ROOF DRAIN CONTROLS NOT MODELLED FOR REGIONAL EVENT **
*ROUTE RESERVOIR
IDout= 3 , NHYD= 200 , IDin= 2 ,
RDT=[1] (min) ,
TABLE of ( OUTFLOW-STORAGE ) values
(cms) - (ha-m)
* 0 0
* 0.1401 0.20579
* 0.1861 0.35601
* 0.2322 0.50622
* 2.0000 0.50700
* -1 -1
* IDovf=7, NHYDovf=1007
-----
ADD HYD (000503) | ID: NHYD AREA QPEAK TPEAK R.V. DWF
(cms) (ha) (cms) (hrs) (mm) (cms)
ID1 01:001 5.90 .864 10.00 206.25 .000
+ID2 02:002 6.01 .884 10.00 209.63 .000
-----
SUM 04:000503 11.91 1.749 10.00 207.95 .000
-----
NOTE: PEAK FLOWS DO NOT INCLUDE BASEFLOWS IF ANY.
-----
001:0006
*****
*STORMWATER MANAGEMENT
*BELOW GROUND STORAGE SYSTEM
*BOTTOM ELEV:90.0m ; TOP ELEV 92.06
-----

```

```

*EROS/EXT ELEV 91.10, EROS VOL 2,581m3
*ORIFICE 1: ELEV 89.15, 63mm ORIFICE
*ORIFICE 2: ELEV 91.80, 260mm DIA. AFTER WEIR WALL AT 91.10
*STORMTECH CHAMBERS MC-4500 - 1,837m3
*SURFACE DRY POND AREA - 3,405m3
*SURFACE STORAGE - 0.25m DEEP - 820m3
*TOTAL VOLUME: 5,077 m3
*EMERGENCY OVERFLOW AT 93.80 - 21.0m WIDE SPILLWAY
*****
Requested routing time step = 1.0 min.
-----
ROUTE RESERVOIR
IN>04: (000503)
OUT<05: (000201)
-----

```

OUTFLOW (cms)	STORAGE (ha.m.)	OUTFLOW STORAGE TABLE (cms)	STORAGE (ha.m.)	STORAGE (ha.m.)
.000	.0000E+00	.014	.2496E+00	.2496E+00
.008	.7000E-02	.014	.2629E+00	.2629E+00
.009	.1430E-01	.054	.2764E+00	.2764E+00
.010	.4160E-01	.068	.2841E+00	.2841E+00
.010	.7150E-01	.128	.3242E+00	.3242E+00
.011	.1023E+00	.170	.3792E+00	.3792E+00
.012	.1626E+00	.204	.4455E+00	.4455E+00
.013	.1937E+00	.219	.5653E+00	.5653E+00
.014	.2233E+00	3.203	.1032E+01	.1032E+01
.014	.2366E+00	10.808	.1321E+01	.1321E+01

```

ROUTING RESULTS
-----
INFLOW >04: (000503) 11.91 1.749 10.000 207.954
OUTFLOW <05: (000201) 11.91 1.602 10.017 207.954
-----
PEAK FLOW REDUCTION [Qout/Qin] (%) = 91.592
TIME SHIFT OF PEAK FLOW (min) = 1.00
MAXIMUM STORAGE USED (ha.m.) = .7817E+00
-----
001:0007
* MODEL SIMULATION OF THE THREE STAGES OF PUMPING
* P1=14 l/s, P1+P2=76l/s, P1+P2+P3=221 l/s
* EMERGENCY OVERFLOW AT 93.80 - 21.0m WIDE SPILLWAY
-----
ROUTE RESERVOIR
IN>04: (000503)
OUT<06: (000200)
-----

```

OUTFLOW (cms)	STORAGE (ha.m.)	OUTFLOW STORAGE TABLE (cms)	STORAGE (ha.m.)	STORAGE (ha.m.)
.000	.0000E+00	.211	.4287E+00	.4287E+00
.012	.1000E-02	.221	.5653E+00	.5653E+00
.014	.2496E+00	3.205	.9331E+00	.9331E+00
.075	.2600E+00	10.808	.1223E+01	.1223E+01
.076	.4277E+00	.000	.0000E+00	.0000E+00

```

ROUTING RESULTS
-----
INFLOW >04: (000503) 11.91 1.749 10.000 207.954
OUTFLOW <06: (000200) 11.91 1.665 10.017 207.954
-----
PEAK FLOW REDUCTION [Qout/Qin] (%) = 95.217
TIME SHIFT OF PEAK FLOW (min) = 1.00
MAXIMUM STORAGE USED (ha.m.) = .7433E+00
-----

```

001:0008-----
 * PUMPS INOPERABLE - OVERLAND SPILLWAY ONLY
 * EMERGENCY OVERFLOW AT 93.80 - 21.0m WIDE SPILLWAY

Requested routing time step = 1.0 min.

ROUTE RESERVOIR	OUTFLOW STORAGE	OUTFLOW STORAGE TABLE	STORAGE
IN>04: (000503)	(ha.m.)	(cms)	(ha.m.)
OUT<06: (000200)	.000 .0000E+00	3.205	.9331E+00
	.002 .5077E+00	10.808	.1223E+01

ROUTING RESULTS	AREA	QPEAK	TPEAK	R.V.
INFLOW >04: (000503)	(ha)	(cms)	(hrs)	(mm)
OUTFLOW <06: (000200)	11.91	1.749	10.000	207.954
	11.91	1.648	10.017	177.459

PEAK FLOW REDUCTION [Qout/Qin](%) = 94.217
 TIME SHIFT OF PEAK FLOW (min) = 1.00
 MAXIMUM STORAGE USED (ha.m.) = .7263E+00

*** WARNING: Outflow volume is less than inflow volume.

001:0009-----
 FINISH

 WARNINGS / ERRORS / NOTES

001:0008 ROUTE RESERVOIR
 *** WARNING: Outflow volume is less than inflow volume.
 Simulation ended on 2022-12-16 at 11:17:19

APPENDIX D
JELLYFISH DESIGN BRIEF



STANDARD OFFLINE Jellyfish Filter Sizing Report

Project Information

Date	Wednesday, March 24, 2021
Project Name	772 Winston Churchill Blvd.
Project Number	Split 3
Location	Oakville

Jellyfish Filter Design Overview

This report provides information for the sizing and specification of the Jellyfish Filter. When designed properly in accordance to the guidelines detailed in the Jellyfish Filter Technical Manual, the Jellyfish Filter will exceed the performance and longevity of conventional horizontal bed and granular media filters.

Please see www.ImbriumSystems.com for more information.

Jellyfish Filter System Recommendation

The Jellyfish Filter model JF12-20-5 is recommended to meet the water quality objective by treating a flow of 113.6 L/s, which meets or exceeds 90% of the average annual rainfall runoff volume based on 18 years of TORONTO CENTRAL rainfall data for this site. This model has a sediment capacity of 1280 kg, which meets or exceeds the estimated average annual sediment load.

Jellyfish Model	Number of High-Flo Cartridges	Number of Draindown Cartridges	Manhole Diameter (m)	Treatment Flow Rate (L/s)	Sediment Capacity (kg)
JF12-20-5	20	5	3.6	113.6	1280

The Jellyfish Filter System

The patented Jellyfish Filter is an engineered stormwater quality treatment technology featuring unique membrane filtration in a compact stand-alone treatment system that removes a high level and wide variety of stormwater pollutants. Exceptional pollutant removal is achieved at high treatment flow rates with minimal head loss and low maintenance costs. Each lightweight Jellyfish Filter cartridge contains an extraordinarily large amount of membrane surface area, resulting in superior flow capacity and pollutant removal capacity.

Maintenance

Regular scheduled inspections and maintenance is necessary to assure proper functioning of the Jellyfish Filter. The maintenance interval is designed to be a minimum of 12 months, but this will vary depending on site loading conditions and upstream pretreatment measures. Quarterly inspections and inspections after all storms beyond the 5-year event are recommended until enough historical performance data has been logged to comfortably initiate an alternative inspection interval.

Please see www.ImbriumSystems.com for more information.

Thank you for the opportunity to present this information to you and your client.

Performance

Jellyfish efficiently captures a high level of Stormwater pollutants, including:

- ☑ 89% of the total suspended solids (TSS) load, including particles less than 5 microns
- ☑ 59% TP removal & 51% TN removal
- ☑ 90% Total Copper, 81% Total Lead, 70% Total Zinc
- ☑ Particulate-bound pollutants such as nutrients, toxic metals, hydrocarbons and bacteria
- ☑ Free oil, Floatable trash and debris

Field Proven Performance

The Jellyfish filter has been field-tested on an urban site with 25 TARP qualifying rain events and field monitored according to the TARP field test protocol, demonstrating:

- A median TSS removal efficiency of 89%, and a median SSC removal of 99%;
- The ability to capture fine particles as indicated by an effluent d50 median of 3 microns for all monitored storm events, and a median effluent turbidity of 5 NTUs;
- A median Total Phosphorus removal of 59%, and a median Total Nitrogen removal of 51%.

Jellyfish Filter Treatment Functions

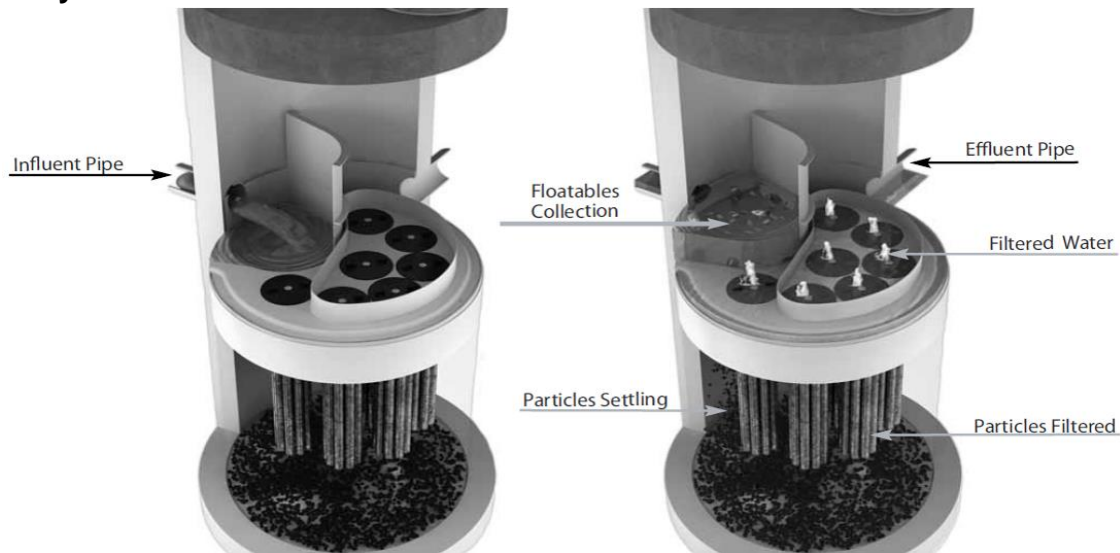

Pre-treatment and Membrane Filtration

Project Information

Date:	Wednesday, March 24, 2021
Project Name:	772 Winston Churchill Blvd.
Project Number:	Split 3
Location:	Oakville

Designer Information

Company:	A.M. Candaras Associates Inc.
Contact:	Fanche Petkovski
Phone #:	

Notes

--

Design System Requirements

Flow Loading	90% of the Average Annual Runoff based on 18 years of TORONTO CENTRAL rainfall data:	80.4 L/s
Sediment Loading	Treating 90% of the average annual runoff volume, 19977 m ³ , with a suspended sediment concentration of 60 mg/L.	1199 kg

Rainfall

Name:	TORONTO CENTRAL
State:	ON
ID:	100
Record:	1982 to 1999
Co-ords:	45°30'N, 90°30'W

Drainage Area

Total Area:	3.98 ha
Imperviousness:	85%

Upstream Detention

Peak Release Rate:	n/a
Pretreatment Credit:	n/a

Recommendation

The Jellyfish Filter model JF12-20-5 is recommended to meet the water quality objective by treating a flow of 113.6 L/s, which meets or exceeds 90% of the average annual rainfall runoff volume based on 18 years of TORONTO CENTRAL rainfall data for this site. This model has a sediment capacity of 1280 kg, which meets or exceeds the estimated average annual sediment load.

Jellyfish Model	Number of High-Flo Cartridges	Number of Draindown Cartridges	Manhole Diameter (m)	Wet Vol Below Deck (L)	Sump Storage (m ³)	Oil Capacity (L)	Treatment Flow Rate (L/s)	Sediment Capacity (kg)
JF4-1-1	1	1	1.2	2313	0.34	379	7.6	85
JF4-2-1	2	1	1.2	2313	0.34	379	12.6	142
JF6-3-1	3	1	1.8	5205	0.79	848	17.7	199
JF6-4-1	4	1	1.8	5205	0.79	848	22.7	256
JF6-5-1	5	1	1.8	5205	0.79	848	27.8	313
JF6-6-1	6	1	1.8	5205	0.79	848	28.6	370
JF8-6-2	6	2	2.4	9252	1.42	1469	35.3	398
JF8-7-2	7	2	2.4	9252	1.42	1469	40.4	455
JF8-8-2	8	2	2.4	9252	1.42	1469	45.4	512
JF8-9-2	9	2	2.4	9252	1.42	1469	50.5	569
JF8-10-2	10	2	2.4	9252	1.42	1469	50.5	626
JF10-11-3	11	3	3.0	14456	2.21	2302	63.1	711
JF10-12-3	12	3	3.0	14456	2.21	2302	68.2	768
JF10-12-4	12	4	3.0	14456	2.21	2302	70.7	796
JF10-13-4	13	4	3.0	14456	2.21	2302	75.7	853
JF10-14-4	14	4	3.0	14456	2.21	2302	78.9	910
JF10-15-4	15	4	3.0	14456	2.21	2302	78.9	967
JF10-16-4	16	4	3.0	14456	2.21	2302	78.9	1024
JF10-17-4	17	4	3.0	14456	2.21	2302	78.9	1081
JF10-18-4	18	4	3.0	14456	2.21	2302	78.9	1138
JF10-19-4	19	4	3.0	14456	2.21	2302	78.9	1195
JF12-20-5	20	5	3.6	20820	3.2	2771	113.6	1280
JF12-21-5	21	5	3.6	20820	3.2	2771	113.7	1337
JF12-22-5	22	5	3.6	20820	3.2	2771	113.7	1394
JF12-23-5	23	5	3.6	20820	3.2	2771	113.7	1451
JF12-24-5	24	5	3.6	20820	3.2	2771	113.7	1508
JF12-25-5	25	5	3.6	20820	3.2	2771	113.7	1565
JF12-26-5	26	5	3.6	20820	3.2	2771	113.7	1622
JF12-27-5	27	5	3.6	20820	3.2	2771	113.7	1679

Jellyfish Filter Design Notes

- Typically the Jellyfish Filter is designed in an offline configuration, as all stormwater filter systems will perform for a longer duration between required maintenance services when designed and applied in off-line configurations. Depending on the design parameters, an optional internal bypass may be incorporated into the Jellyfish Filter, however note the inspection and maintenance frequency should be expected to increase above that of an off-line system. Speak to your local representative for more information.

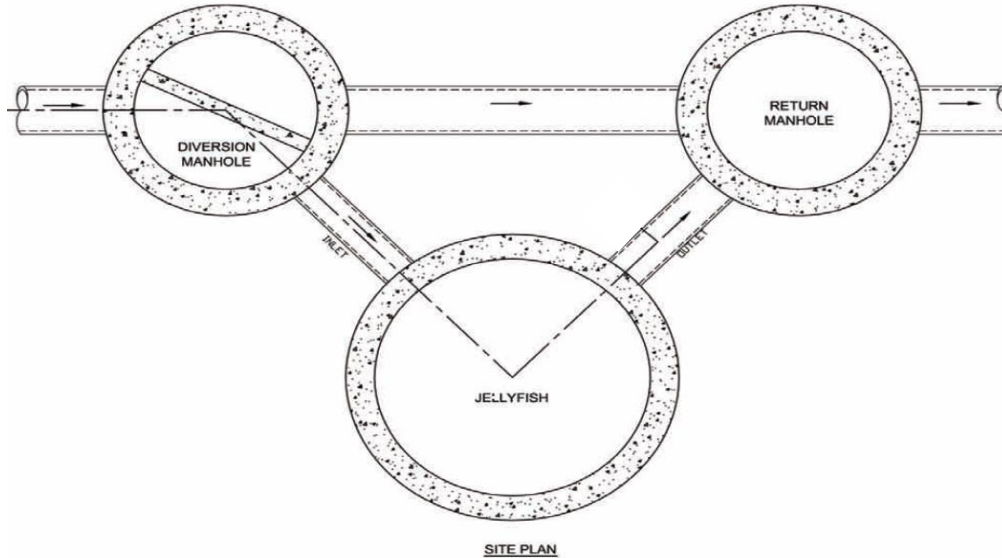

Jellyfish Filter Typical Layout

- Typically, 18 inches (457 mm) of driving head is designed into the system, calculated as the difference in elevation between the top of the diversion structure weir and the invert of the Jellyfish Filter outlet pipe. Alternative driving head values can be designed as 12 to 24 inches (305 to 610mm) depending on specific site requirements, requiring additional sizing and design assistance.
- Typically, the Jellyfish Filter is designed with the inlet pipe configured 6 inches (150 mm) above the outlet invert elevation. However, depending on site parameters this can vary to an optional configuration of the inlet pipe entering the unit below the outlet invert elevation.
- The Jellyfish Filter can accommodate multiple inlet pipes within certain restrictions.
- While the optional inlet below deck configuration offers 0 to 360 degree flexibility between the inlet and outlet pipe, typical systems conform to the following:

Model Diameter (m)	Minimum Angle Inlet / Outlet Pipes	Minimum Inlet Pipe Diameter (mm)	Minimum Outlet Pipe Diameter (mm)
1.2	62°	150	200
1.8	59°	200	250
2.4	52°	250	300
3.0	48°	300	450
3.6	40°	300	450

- The Jellyfish Filter can be built at all depths of cover generally associated with conventional stormwater conveyance systems. For sites that require minimal depth of cover for the stormwater infrastructure, the Jellyfish Filter can be applied in a shallow application using a hatch cover. The general minimum depth of cover is 36 inches (915 mm) from top of the underslab to outlet invert.
- If driving head calculations account for water elevation during submerged conditions the Jellyfish Filter will function effectively under submerged conditions.
- Jellyfish Filter systems may incorporate grated inlets depending on system configuration.
- For sites with water quality treatment flow rates or mass loadings that exceed the design flow rate of the largest standard Jellyfish Filter manhole models, systems can be designed that hydraulically connect multiple Jellyfish Filters in series or alternatively Jellyfish Vault units can be designed.

STANDARD SPECIFICATION STORMWATER QUALITY – MEMBRANE FILTRATION TREATMENT DEVICE

PART 1 – GENERAL

1.1 WORK INCLUDED

Specifies requirements for construction and performance of an underground stormwater quality membrane filtration treatment device that removes pollutants from stormwater runoff through the unit operations of sedimentation, floatation, and membrane filtration.

1.2 REFERENCE STANDARDS

ASTM C 891: Specification for Installation of Underground Precast Concrete Utility Structures
ASTM C 478: Specification for Precast Reinforced Concrete Manhole Sections
ASTM C 443: Specification for Joints for Concrete Pipe and Manholes, Using Rubber Gaskets
ASTM D 4101: Specification for Copolymer steps construction

CAN/CSA-A257.4-M92

Joints for Circular Concrete Sewer and Culvert Pipe, Manhole Sections and Fittings Using Rubber Gaskets

CAN/CSA-A257.4-M92

Precast Reinforced Circular Concrete Manhole Sections, Catch Basins and Fittings

Canadian Highway Bridge Design Code

1.3 SHOP DRAWINGS

Shop drawings for the structure and performance are to be submitted with each order to the contractor. Contractor shall forward shop drawing submittal to the consulting engineer for approval. Shop drawings are to detail the structure's precast concrete and call out or note the fiberglass (FRP) internals/components.

1.4 PRODUCT SUBSTITUTIONS

No product substitutions shall be accepted unless submitted 10 days prior to project bid date, or as directed by the engineer of record. Submissions for substitutions require review and approval by the Engineer of Record, for hydraulic performance, impact to project designs, equivalent treatment performance, and any required project plan and report (hydrology/hydraulic, water quality, stormwater pollution) modifications that would be required by the approving jurisdictions/agencies. Contractor to coordinate with the Engineer of Record any applicable modifications to the project estimates of cost, bonding amount determinations, plan check fees for changes to approved documents, and/or any other regulatory requirements resulting from the product substitution.

1.5 HANDLING AND STORAGE

Prevent damage to materials during storage and handling.

PART 2 – PRODUCTS

2.1 GENERAL

- 2.1.1 The device shall be a cylindrical or rectangular, all concrete structure (including risers), constructed from precast concrete riser and slab components or monolithic precast structure(s), installed to conform to ASTM C 891 and to any required state highway, municipal or local specifications; whichever is more stringent. The device shall be watertight.
- 2.1.2 Cartridge Deck The cylindrical concrete device shall include a fiberglass deck. The rectangular concrete device shall include a coated aluminum deck. In either instance, the insert shall be bolted and sealed watertight inside the precast concrete chamber. The deck shall serve as: (a) a horizontal divider between the lower treatment zone and the upper treated effluent zone; (b) a deck for attachment of filter cartridges such that the membrane filter elements of each cartridge extend into the lower treatment zone; (c) a platform for maintenance workers to service the filter cartridges (maximum manned weight = 450 pounds (204 kg)); (d) a conduit for conveyance of treated water to the effluent pipe.
- 2.1.3 Membrane Filter Cartridges Filter cartridges shall be comprised of reusable cylindrical membrane filter elements connected to a perforated head plate. The number of membrane filter elements per cartridge shall be a minimum of eleven 2.75-inch (70-mm) diameter elements. The length of each filter element shall be a minimum 15 inches (381 mm). Each cartridge shall be fitted into the cartridge deck by insertion into a cartridge receptacle that is permanently mounted into the cartridge deck. Each cartridge shall be secured by a cartridge lid that is threaded onto the receptacle, or similar mechanism to secure the cartridge into the deck. The maximum treatment flow rate of a filter cartridge shall be controlled by an orifice in the cartridge lid, or on the individual cartridge itself, and based on a design flux rate (surface loading rate) determined by the maximum treatment flow rate per unit of filtration membrane surface area. The maximum design flux rate shall be 0.21 gpm/ft² (0.142 lps/m²).

Each membrane filter cartridge shall allow for manual installation and removal. Each filter cartridge shall have filtration membrane surface area and dry installation weight as follows (if length of filter cartridge is between those listed below, the surface area and weight shall be proportionate to the next length shorter and next length longer as shown below):

Filter Cartridge Length (in / mm)	Minimum Filtration Membrane Surface Area (ft ² / m ²)	Maximum Filter Cartridge Dry Weight (lbs / kg)
15	106 / 9.8	10.5 / 4.8
27	190 / 17.7	15.0 / 6.8
40	282 / 26.2	20.5 / 9.3
54	381 / 35.4	25.5 / 11.6

- 2.1.4 Backwashing Cartridges The filter device shall have a weir extending above the cartridge deck, or other mechanism, that encloses the high flow rate filter cartridges when placed in their respective cartridge receptacles within the cartridge deck. The weir, or other mechanism, shall collect a pool of filtered water during inflow events that backwashes the high flow rate cartridges when the inflow

event subsides. All filter cartridges and membranes shall be reusable and allow for the use of filtration membrane rinsing procedures to restore flow capacity and sediment capacity; extending cartridge service life.

- 2.1.5 Maintenance Access to Captured Pollutants The filter device shall contain an opening(s) that provides maintenance access for removal of accumulated floatable pollutants and sediment, removal of and replacement of filter cartridges, cleaning of the sump, and rinsing of the deck. Access shall have a minimum clear vertical clear space over all of the filter cartridges. Filter cartridges shall be able to be lifted straight vertically out of the receptacles and deck for the entire length of the cartridge.
- 2.1.6 Bend Structure The device shall be able to be used as a bend structure with minimum angles between inlet and outlet pipes of 90-degrees or less in the stormwater conveyance system.
- 2.1.7 Double-Wall Containment of Hydrocarbons The cylindrical precast concrete device shall provide double-wall containment for hydrocarbon spill capture by a combined means of an inner wall of fiberglass, to a minimum depth of 12 inches (305 mm) below the cartridge deck, and the precast vessel wall.
- 2.1.8 Baffle The filter device shall provide a baffle that extends from the underside of the cartridge deck to a minimum length equal to the length of the membrane filter elements. The baffle shall serve to protect the membrane filter elements from contamination by floatables and coarse sediment. The baffle shall be flexible and continuous in cylindrical configurations, and shall be a straight concrete or aluminum wall in rectangular configurations.
- 2.1.9 Sump The device shall include a minimum 24 inches (610 mm) of sump below the bottom of the cartridges for sediment accumulation, unless otherwise specified by the design engineer. Depths less than 24 inches may have an impact on the total performance and/or longevity between cartridge maintenance/replacement of the device.

2.2 PRECAST CONCRETE SECTIONS

All precast concrete components shall be manufactured to a minimum live load of HS-20 truck loading or greater based on local regulatory specifications, unless otherwise modified or specified by the design engineer, and shall be watertight.

2.3 JOINTS All precast concrete manhole configuration joints shall use nitrile rubber gaskets and shall meet the requirements of ASTM C443, Specification C1619, Class D or engineer approved equal to ensure oil resistance. Mastic sealants or butyl tape are not an acceptable alternative.

2.4 GASKETS Only profile neoprene or nitrile rubber gaskets in accordance to CSA A257.3-M92 will be accepted. Mastic sealants, butyl tape or Conseal CS-101 are not acceptable gasket materials.

2.5 FRAME AND COVER Frame and covers must be manufactured from cast-iron or other composite material tested to withstand H-20 or greater design loads, and as approved by the

local regulatory body. Frames and covers must be embossed with the name of the device manufacturer or the device brand name.

- 2.6 DOORS AND HATCHES If provided shall meet designated loading requirements or at a minimum for incidental vehicular traffic.
- 2.7 CONCRETE All concrete components shall be manufactured according to local specifications and shall meet the requirements of ASTM C 478.
- 2.8 FIBERGLASS The fiberglass portion of the filter device shall be constructed in accordance with the following standard: ASTM D-4097: Contact Molded Glass Fiber Reinforced Chemical Resistant Tanks.
- 2.9 STEPS Steps shall be constructed according to ASTM D4101 of copolymer polypropylene, and be driven into preformed or pre-drilled holes after the concrete has cured, installed to conform to applicable sections of state, provincial and municipal building codes, highway, municipal or local specifications for the construction of such devices.
- 2.10 INSPECTION All precast concrete sections shall be inspected to ensure that dimensions, appearance and quality of the product meet local municipal specifications and ASTM C 478.

PART 3 – PERFORMANCE

3.1 GENERAL

- 3.1.1 Verification – The stormwater quality filter must be verified in accordance with ISO 14034:2016 Environmental management – Environmental technology verification (ETV).
- 3.1.2 Function - The stormwater quality filter treatment device shall function to remove pollutants by the following unit treatment processes; sedimentation, floatation, and membrane filtration.
- 3.1.3 Pollutants - The stormwater quality filter treatment device shall remove oil, debris, trash, coarse and fine particulates, particulate-bound pollutants, metals and nutrients from stormwater during runoff events.
- 3.1.4 Bypass - The stormwater quality filter treatment device shall typically utilize an external bypass to divert excessive flows. Internal bypass systems shall be equipped with a floatables baffle, and must avoid passage through the sump and/or cartridge filtration zone.
- 3.1.5 Treatment Flux Rate (Surface Loading Rate) – The stormwater quality filter treatment device shall treat 100% of the required water quality treatment flow based on a maximum design treatment flux rate (surface loading rate) across the membrane filter cartridges of 0.21 gpm/ft² (0.142 lps/m²).

3.2 FIELD TEST PERFORMANCE

At a minimum, the stormwater quality filter device shall have been field tested and verified with a minimum 25 TARP qualifying storm events and field monitoring shall have been conducted according to the TARP 2009 NJDEP TARP field test protocol, and have received NJCAT verification.

- 3.2.1 Suspended Solids Removal - The stormwater quality filter treatment device shall have demonstrated a minimum median TSS removal efficiency of 85% and a minimum median SSC removal efficiency of 95%.
- 3.2.2 Runoff Volume – The stormwater quality filter treatment device shall be engineered, designed, and sized to treat a minimum of 90 percent of the annual runoff volume determined from use of a minimum 15-year rainfall data set.
- 3.2.3 Fine Particle Removal - The stormwater quality filter treatment device shall have demonstrated the ability to capture fine particles as indicated by a minimum median removal efficiency of 75% for the particle fraction less than 25 microns, an effluent d_{50} of 15 microns or lower for all monitored storm events.
- 3.2.4 Turbidity Reduction - The stormwater quality filter treatment device shall have demonstrated the ability to reduce the turbidity from influent from a range of 5 to 171 NTU to an effluent turbidity of 15 NTU or lower.
- 3.2.5 Nutrient (Total Phosphorus & Total Nitrogen) Removal - The stormwater quality filter treatment device shall have demonstrated a minimum median Total Phosphorus removal of 55%, and a minimum median Total Nitrogen removal of 50%.
- 3.2.6 Metals (Total Zinc & Total Copper) Removal - The stormwater quality filter treatment device shall have demonstrated a minimum median Total Zinc removal of 55%, and a minimum median Total Copper removal of 85%.

3.3 INSPECTION and MAINTENANCE

The stormwater quality filter device shall have the following features:

- 3.3.1 Durability of membranes are subject to good handling practices during inspection and maintenance (removal, rinsing, and reinsertion) events, and site specific conditions that may have heavier or lighter loading onto the cartridges, and pollutant variability that may impact the membrane structural integrity. Membrane maintenance and replacement shall be in accordance with manufacturer's recommendations.
- 3.3.2 Inspection which includes trash and floatables collection, sediment depth determination, and visible determination of backwash pool depth shall be easily conducted from grade (outside the structure).
- 3.3.3 Manual rinsing of the reusable filter cartridges shall promote restoration of the flow capacity and sediment capacity of the filter cartridges, extending cartridge service life.

- 3.3.4 The filter device shall have a minimum 12 inches (305 mm) of sediment storage depth, and a minimum of 12 inches between the top of the sediment storage and bottom of the filter cartridge tentacles, unless otherwise specified by the design engineer. Variances may have an impact on the total performance and/or longevity between cartridge maintenance/replacement of the device.
- 3.3.5 Sediment removal from the filter treatment device shall be able to be conducted using a standard maintenance truck and vacuum apparatus, and a minimum one point of entry to the sump that is unobstructed by filter cartridges.
- 3.3.6 Maintenance access shall have a minimum clear height that provides suitable vertical clear space over all of the filter cartridges. Filter cartridges shall be able to be lifted straight vertically out of the receptacles and deck for the entire length of the cartridge.
- 3.3.7 Filter cartridges shall be able to be maintained without the requirement of additional lifting equipment.

PART 4 – EXECUTION

4.1 INSTALLATION

4.1.1 PRECAST DEVICE CONSTRUCTION SEQUENCE

The installation of a watertight precast concrete device should conform to ASTM C 891 and to any state highway, municipal or local specifications for the construction of manholes, whichever is more stringent. Selected sections of a general specification that are applicable are summarized below.

- 4.1.1.1 The watertight precast concrete device is installed in sections in the following sequence:
 - aggregate base
 - base slab
 - treatment chamber and cartridge deck riser section(s)
 - bypass section
 - connect inlet and outlet pipes
 - concrete riser section(s) and/or transition slab (if required)
 - maintenance riser section(s) (if required)
 - frame and access cover

4.1.2 The precast base should be placed level at the specified grade. The entire base should be in contact with the underlying compacted granular material. Subsequent sections, complete with joint seals, should be installed in accordance with the precast concrete manufacturer's recommendations.

4.1.3 Adjustment of the stormwater quality treatment device can be performed by lifting the upper sections free of the excavated area, re-leveling the base, and re-installing the sections. Damaged sections and gaskets should be repaired or replaced as necessary to restore original condition and watertight seals. Once the stormwater quality treatment device has been constructed, any/all lift holes must be plugged watertight with mortar or non-shrink grout.

4.1.4 Inlet and Outlet Pipes Inlet and outlet pipes should be securely set into the device using approved pipe seals (flexible boot connections, where applicable) so that the structure is watertight, and such that any pipe intrusion into the device does not impact the device functionality.

4.1.5 Frame and Cover Installation Adjustment units (e.g. grade rings) should be installed to set the frame and cover at the required elevation. The adjustment units should be laid in a full bed of mortar with successive units being joined using sealant recommended by the manufacturer. Frames for the cover should be set in a full bed of mortar at the elevation specified.

4.2 MAINTENANCE ACCESS WALL

In some instances the Maintenance Access Wall, if provided, shall require an extension attachment and sealing to the precast wall and cartridge deck at the job site, rather than at the precast facility. In this instance, installation of these components shall be performed according to instructions provided by the manufacturer.

4.3 FILTER CARTRIDGE INSTALLATION Filter cartridges shall be installed in the cartridge deck only after the construction site is fully stabilized and in accordance with the manufacturer's guidelines and recommendations. Contractor to contact the manufacturer to schedule cartridge delivery and review procedures/requirements to be completed to the device prior to installation of the cartridges and activation of the system.

PART 5 – QUALITY ASSURANCE

5.1 FILTER CARTRIDGE INSTALLATION Manufacturer shall coordinate delivery of filter cartridges and other internal components with contractor. Filter cartridges shall be delivered and installed complete after site is stabilized and unit is ready to accept cartridges. Unit is ready to accept cartridges after it has been cleaned out and any standing water, debris, and other materials have been removed. Contractor shall take appropriate action to protect the filter cartridge receptacles and filter cartridges from damage during construction, and in accordance with the manufacturer's recommendations and guidance. For systems with cartridges installed prior to full site stabilization and prior to system activation, the contractor can plug inlet and outlet pipes to prevent stormwater and other influent from entering the device. Plugs must be removed during the activation process.

5.2 INSPECTION AND MAINTENANCE

5.2.1 The manufacturer shall provide an Owner's Manual upon request.

5.2.2 After construction and installation, and during operation, the device shall be inspected and cleaned as necessary based on the manufacturer's recommended inspection and maintenance guidelines and the local regulatory agency/body.

5.3 REPLACEMENT FILTER CARTRIDGES When replacement membrane filter elements and/or other parts are required, only membrane filter elements and parts approved by the manufacturer for use with the stormwater quality filter device shall be installed.

END OF SECTION

VERIFICATION STATEMENT

GLOBE Performance Solutions

Verifies the performance of

Jellyfish® Filter

Developed by Imbrium Systems, Inc.,
Whitby, Ontario, Canada

Registration: **GPS-ETV_VR2020-08-15_Imbrium-JF**

In accordance with

ISO 14034:2016

**Environmental Management —
Environmental Technology Verification (ETV)**



John D. Wiebe, PhD
Executive Chairman
GLOBE Performance Solutions



August 15, 2020
Vancouver, BC, Canada

Verification Body
GLOBE Performance Solutions
404 – 999 Canada Place | Vancouver, B.C | Canada |V6C 3E2

**APPENDIX E
STORM PUMP
SPECIFICATIONS**

NP 3153 MT 3~436

Duty Analysis



Curves according to: Water, pure [100%]; 4°C; 1kg/dm³; 1.569mm²/s

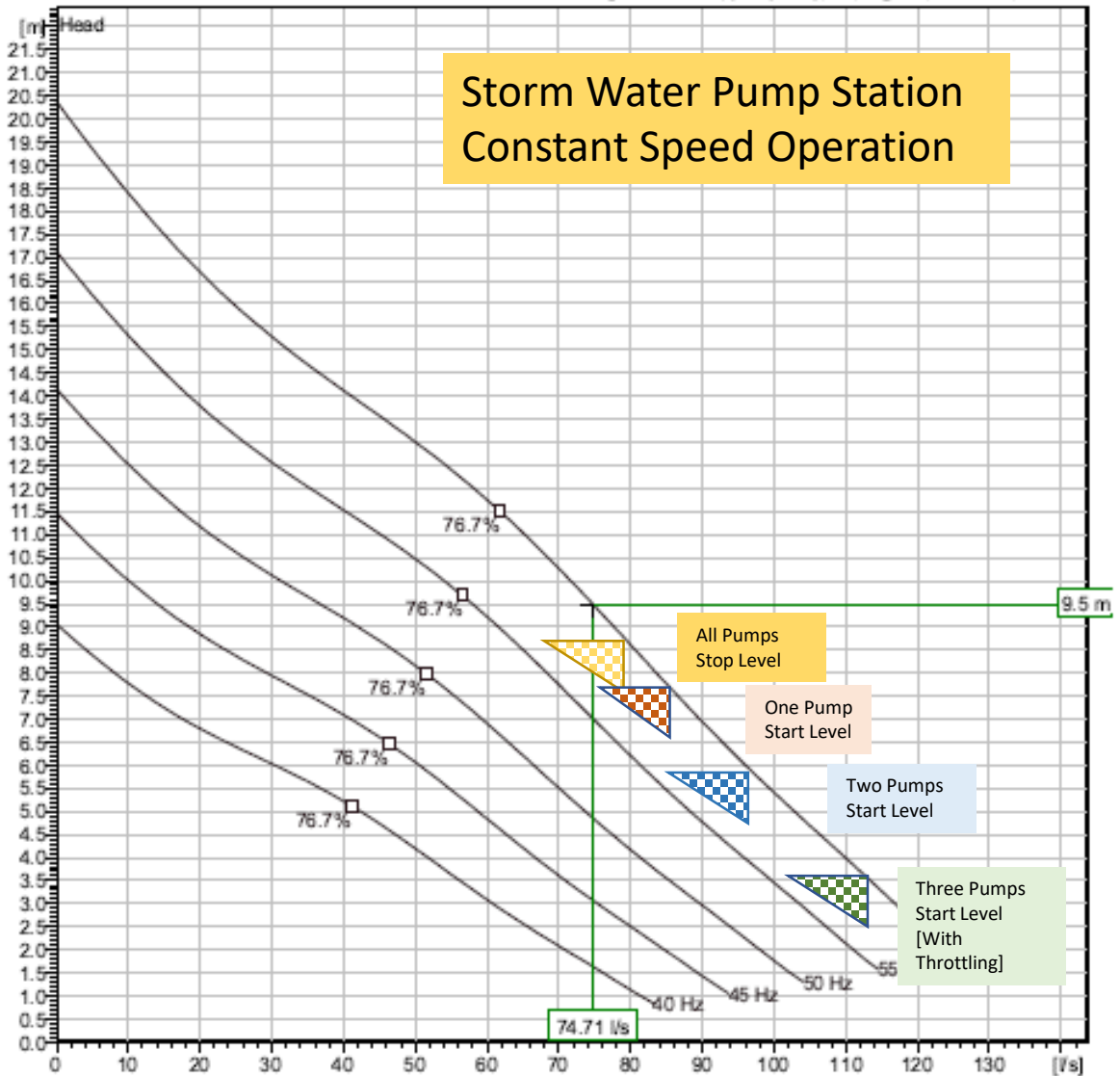

Operating characteristics

Pumps / System	Flow l/s	Head m	Shaft power kW	Flow l/s	Head m	Shaft power kW	Hydr. eff.	Spec. Energy kWh/l	NPSHreq m
1	74.7	9.5	9.5	74.7	9.5	9.5	73.3 %	3.85E-5	6.97

Section 2 Installation Planning

2.1 — Unit Drawings

2.1.1— Installation Drawings

Installation drawings show weights, dimensions, clearances, exhaust details, connection locations, wiring stub-ups, lifting locations, and other information. Use the unit specific installation drawings when designing a site installation plan. Thoroughly read the NOTES section of each drawing for important details.

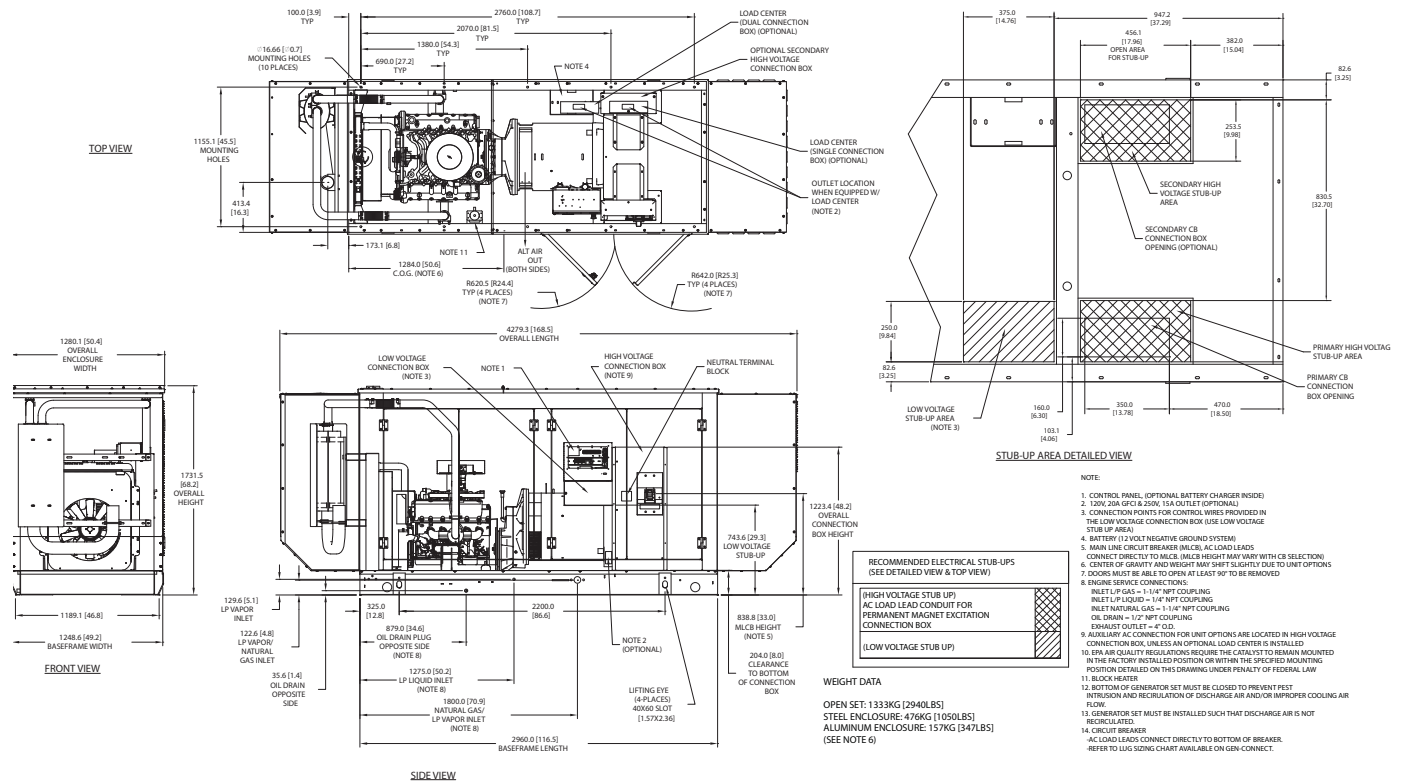

Figure 2-1. Typical Installation Drawing

2.1.2— Wiring Diagrams

Wiring and schematic diagrams show the connection points for control wiring, load wiring, and any service power supply required for battery chargers, block heaters, etc. Always use the unit specific wiring diagrams during planning and installation.

NP 3127 HT 3~ Adaptive 488

14 Eps Pump

VFD Curve



Curves according to: Water, pure, 4 °C, 1 kg/dm³, 1.569 mm²/s

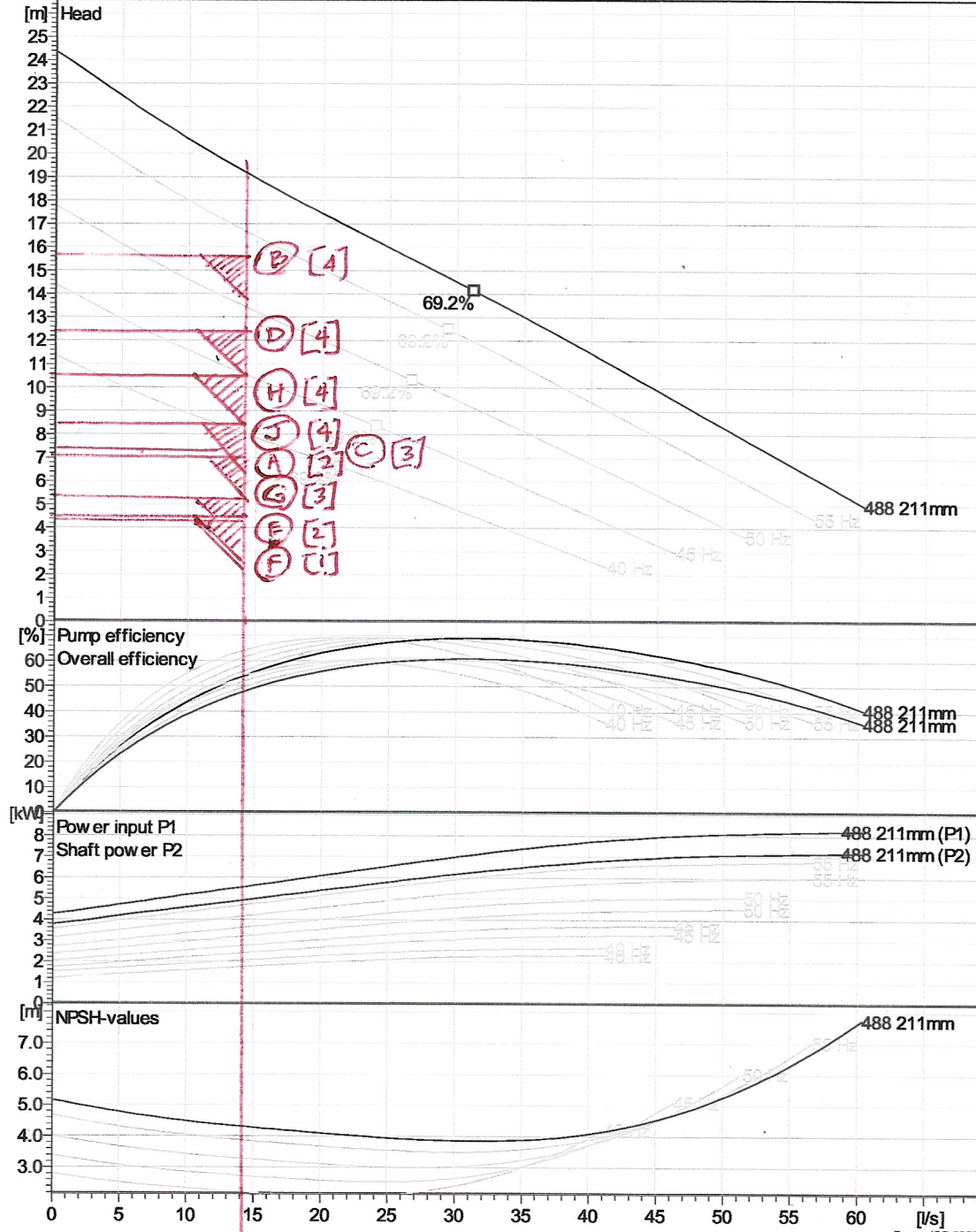

Project
Block 0

Created by Richard Jacobs
Created on 11/27/2021 Last update 11/27/2021

NP 3202 MT 3~ 641

97 lps Pump

VFD Curve

NO (A) SMALL PUMPS ONLY
 NO (E) ——— " ———
 NO (F) ——— " ———



Curves according to: Water, pure, 4 °C, 1 kg/dm³, 1.569 mm²/s

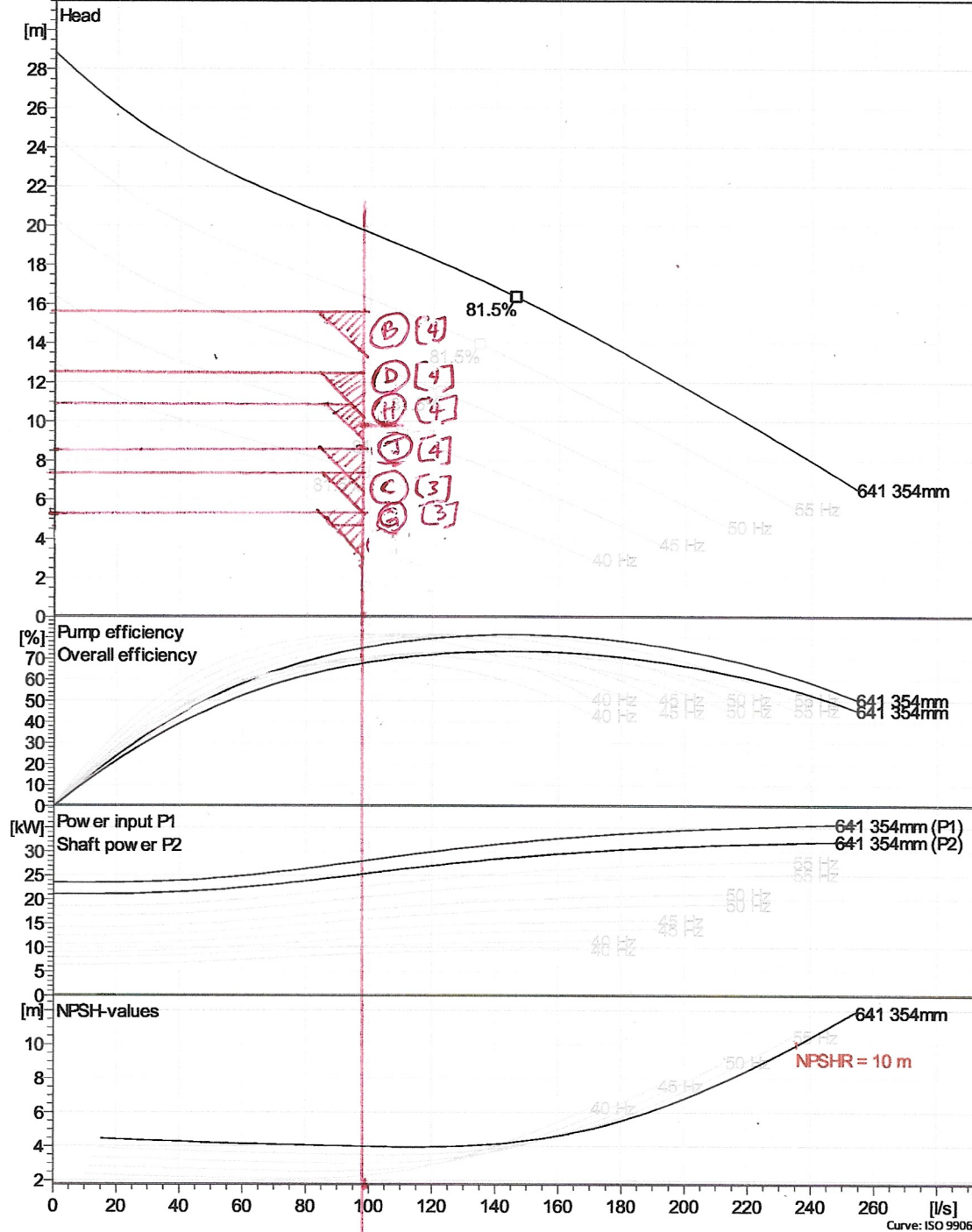

Project
Block 0

Created by Richard Jacobs
 Created on 11/27/2021 Last update 11/27/2021

NP 3153 MT 3~436

Duty Analysis



Curves according to: Water, pure [100%]; 4°C; 1kg/dm³; 1.569mm²/s

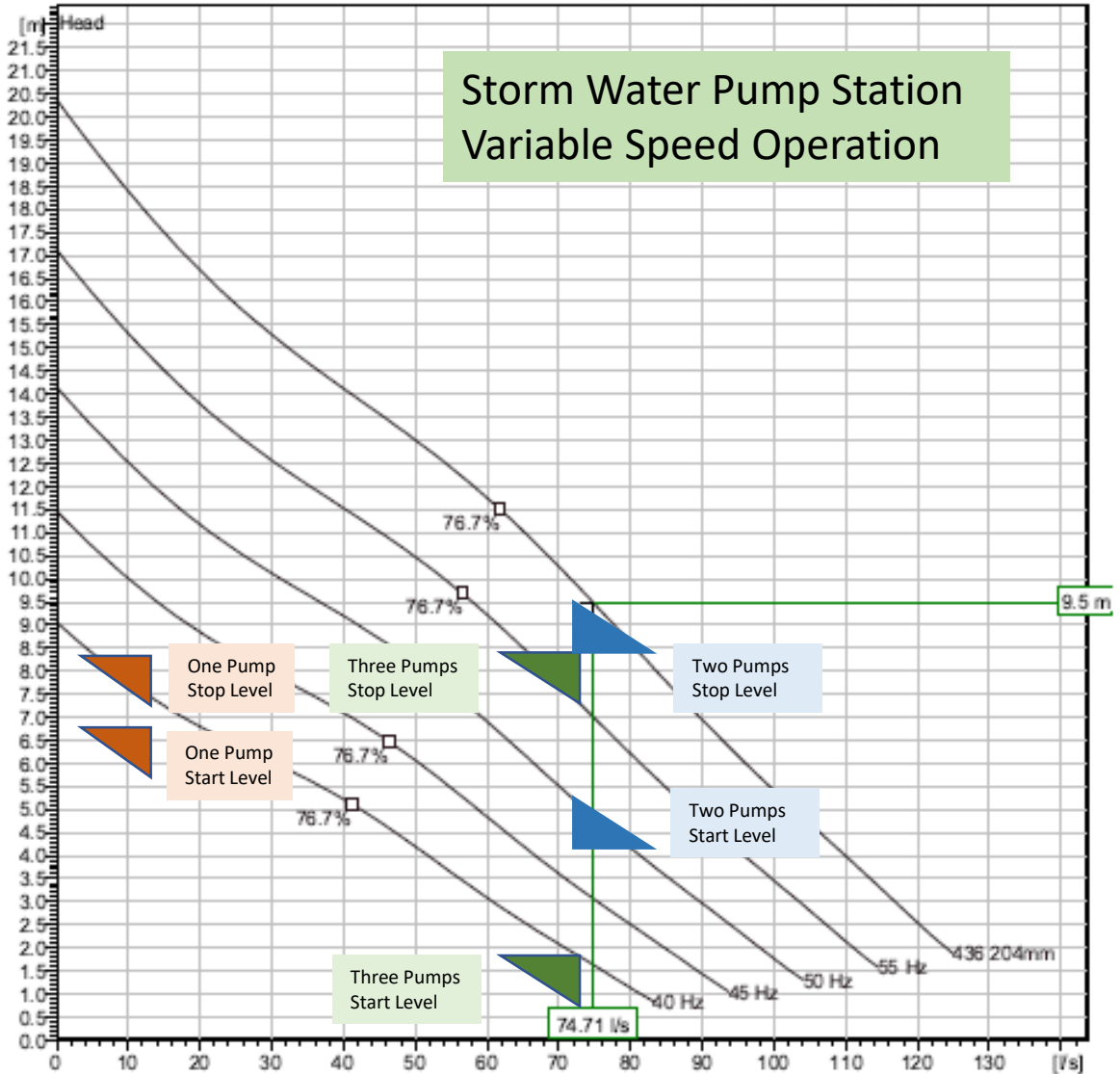

Operating characteristics

Pumps / System	Flow l/s	Head m	Shaft power kW	Flow l/s	Head m	Shaft power kW	Hydr. eff.	Spec. Energy kWh/l	NPSHreq m
1	74.7	9.5	9.5	74.7	9.5	9.5	73.3%	3.85E-5	6.97

APPENDIX F
GEOTECHNICAL REPORT
EXCERPTS



EXP Services Inc.
1595 Clark Boulevard
Brampton, Ontario
L6T 4V1

Telephone:(905) 793 9800

Reference:MRK-00258896-A0

October 23, 2020

Mr. Jamie Bunston
Vice President, Industrial - Greater Toronto Area
One Properties
333 Bay Street – Suite 2710
Toronto, ON
M5H 2R2

Via Email: jbunston@oneproperties.com

Re: **Water Level Readings**
772 Winston Churchill Blvd.
Oakville, Ontario

Dear Jamie:

As requested, a representative from EXP Services Inc. (EXP) visited the above captioned property on October 21, 2020 to record water level readings from the existing monitoring wells present on site. Four (4) monitoring wells in total are currently present on site. The monitoring wells were installed by Forward Engineering & Associates Inc. at the time of their Phase II Environmental Site Assessment in 2016. The locations of these monitoring wells, designated as BH/MW-101, BH/MW-102, BH/MW-103 and BH/MW-110 are shown on the attached Plan (Drawing No. 1). Borehole logs showing well installation details are also attached.

The following table presents the water level readings taken on October 21, 2020 along with other available previous water level readings.

Water Level Readings (in metres below ground surface)			
Monitoring Well ID	February 29, 2016*	March 18, 2020	October 21, 2020
BH/MW 101	1.48	1.20	1.46
BH/MW 102	1.06	0.20	0.90
BH/MW 103	1.67	0.40	0.80
BH/MW 110	2.10	0.90	2.17

*taken from Phase II Environmental Site Assessment Report dated March 21, 2016 prepared by Forward Engineering & Associates Inc.

Should you have any questions, please do not hesitate to contact this office.

Yours truly,

EXP Services Inc.



Aamna Arora, P. Eng.,
Project Manager,
Geotechnical Division



David Dennison, P. Eng.
Senior Geoenvironmental Engineer
Geotechnical Division

BORHOLE LOCATION PLAN

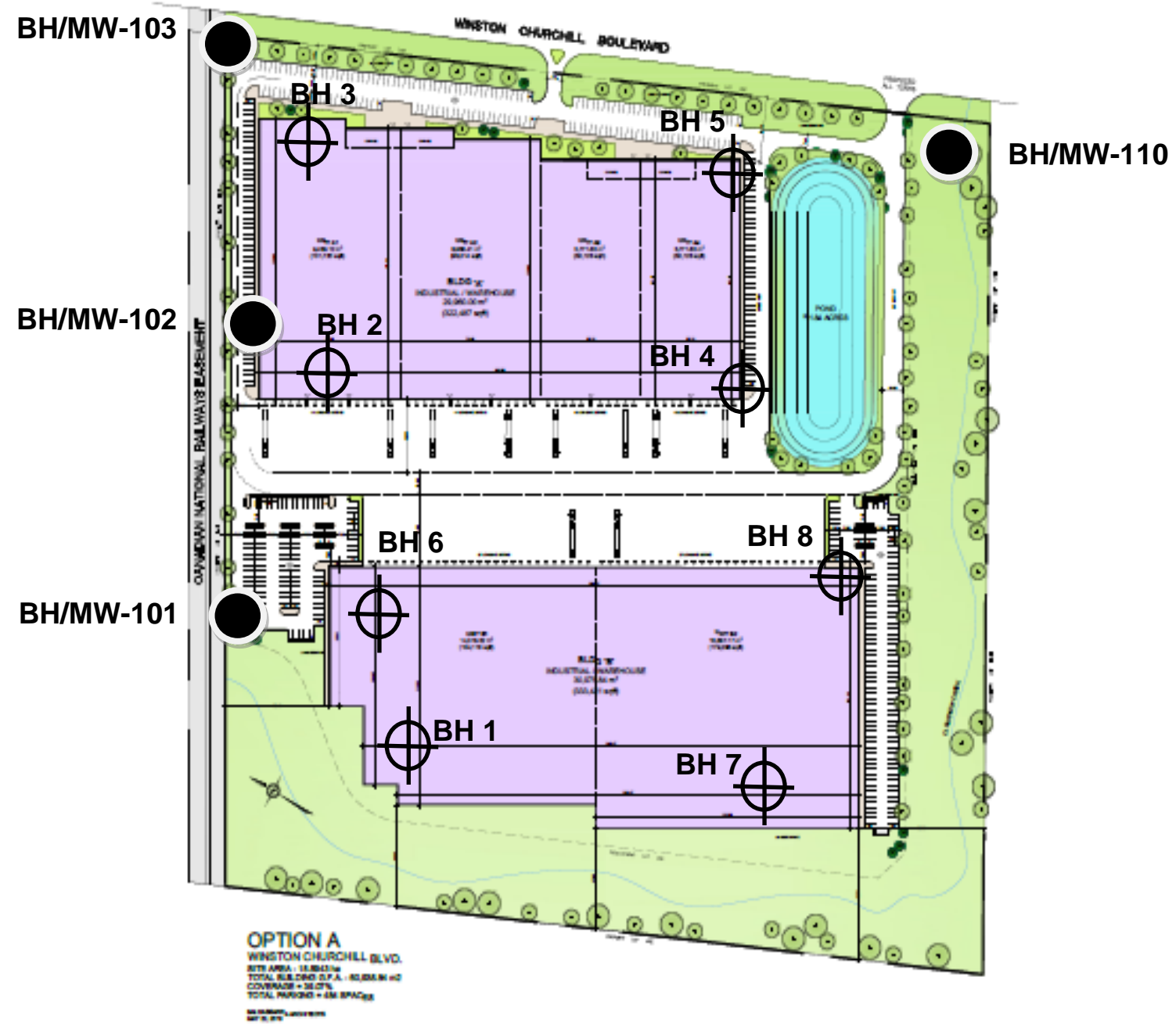

Legend



APPROXIMATE BOREHOLE LOCATION



APPROXIMATE MONITORING WELL LOCATION (2016)



EXP Services Inc.
 1595 Clark Boulevard
 Brampton, Ontario
 L6T 4V1
 Telephone: (905) 793-9800
 Fax: (905) 793-0641

SCALE: NTS

DATE:
 April 2020

DWN.:
 AK

CHKD.:
 AK

Borehole Location Plan
 Preliminary Geotechnical Investigation
 772 Winston Churchill, Oakville, Ontario

PROJECT NO.:
 MRK-00258896-A0

DWG. NO.: 1

BOREHOLE LOGS (From Forward Engg. Phase II ESA Report)

Project No: E-5000

Project: 772 WINSTON CHURCHILL BLVD PROPERTY

Client: SORA GROUP

Location: 772 WINSTON CHURCHILL BLVD., OAKVILLE, ON.

Log of Borehole: BH-101

Enclosure: 2

Technician: P.R.

SUBSURFACE PROFILE			SAMPLE			LEL %LEL				G.W.L	LAB ANALYSIS
Depth	Symbol	Description	Number	Type	Recovery	VOC Concentration ppm					
						100	200	300	400		
0		Ground Surface									
0		FILL/DISTURBED SOIL brown and grey clayey silt fill, slightly sandy and with traces of brick debris in the upper zone, compact, wet.	1		83	NIL	15				SOIL METALS INORGANICS VOC's & PAH's
1		piece of concrete debris, moist.	2		100	NIL	16				
2											
3											
4											
5		CLAYEY SILT TILL/SHALE TILL with occasional inclusions of shale/limestone/siltstone fragments. hard, olive brown, moist. silt till layer.	3		55	NIL	18				
6											
7											
8			4		83						
9											
10		slightly reddish brown shale till below ±3.0 m.	5		67						
11											
12		-(auger grinding) transition zone to weathered shale bedrock.									
13											
14		WEATHERED SHALE hard, grey, moist. refusal at 4.48 m.	6								
15											
16		End of Borehole at 14.67 ft									
17											
18		Upon completion of drilling, the borehole remained open and water level was measured at 4.03 m.									
19											
20											

Drill Method: SOLID AUGER

Drill Date: 01 FEB. 2016

Hole Size: 150 mm

FORWARD ENGINEERING

Datum: ELEV. 94.84 m

Checked by: G.S.

Sheet: 1 of 1

Project No: E-5000

Project: 772 WINSTON CHURCHILL BLVD PROPERTY

Client: SORA GROUP

Location: 772 WINSTON CHURCHILL BLVD., OAKVILLE, ON.

Log of Borehole: BH-102

Enclosure: 3

Technician: P.R.

SUBSURFACE PROFILE			SAMPLE			LEL %LEL				G.W.L	LAB ANALYSIS
Depth	Symbol	Description	Number	Type	Recovery	VOC Concentration ppm					
						100	200	300	400		
0		Ground Surface									
0		FILL/DISTURBED SOIL brown and greyish brown silty and fine sand fill with traces of gravel, compact, wet.	1		100	5		18			SOIL METALS, INORGANICS,
1											
3		CLAYEY SILT TILL/SILT TILL with occasional inclusions of shale/limestone/siltstone fragments. hard, brown, moist.	2		100		NIL	15			WATER METALS, INORGANICS, VOC's & PAH's
4		becoming grey.									
6			3		44		NIL	18			SOIL VOC's & PAH's
7											
8			4								
10											
11		moist silt till with wet fine sandy silt inclusions.	5		67						
12											
13		-(auger grinding) transition zone to weathered shale bedrock.									
14			6								
15		WEATHERED SHALE hard, grey, moist. refusal at 4.44 m.									
16		End of Borehole at 14.58 ft									
17											
18		Upon completion of drilling, the borehole remained open and water level was measured at 0.30 m.									
19											
20											

Drill Method: SOLID AUGER

Drill Date: 01 FEB. 2016

Hole Size: 150 mm

FORWARD ENGINEERING

Datum: ELEV. 94.75 m

Checked by: G.S.

Sheet: 1 of 1

Project No: E-5000

Project: 772 WINSTON CHURCHILL BLVD PROPERTY

Client: SORA GROUP

Location: 772 WINSTON CHURCHILL BLVD., OAKVILLE, ON.

Log of Borehole: BH-103

Enclosure: 4

Technician: P.R.

SUBSURFACE PROFILE			SAMPLE			LEL %LEL				G.W.L	LAB ANALYSIS	
Depth	Symbol	Description	Number	Type	Recovery	VOC Concentration ppm						
						■	■	■	■			
0		Ground Surface										
0-1	▨	FILL/DISTURBED SOIL brown clayey silt and silty sand fill, very loose to compact, wet.	1	▬▬	54	■	■	●	●	25	16	SOIL METALS INORGANICS VOC's & PAH's
1-3	▨	CLAYEY SILT TILL/SILT TILL with occasional inclusions of shale/limestone/siltstone fragments. very stiff, brown, rust brown and grey, moist.	2	▬▬	83	■	■	●	●	NIL	17	
3-5	▨		3	▬▬	83	■	■	●	●	NIL	NIL	
5-8	▨	hard below ±2.3 m.	4	▬▬	91	■	■	●	●	NIL	NIL	
8-11	▨	olive brown silt till with shale fragments.	5	▬▬	56	■	■	●	●	NIL	NIL	
11-12	▨	-(auger grinding) transition zone to weathered shale bedrock.										
12-13	▨	WEATHERED SHALE hard, grey, moist. refusal at 3.99 m.	6	▬▬								WATER METALS INORGANICS VOC's & PAH's
13-14		End of Borehole at 13.08 ft										
14-20		Upon completion of drilling, the borehole remained open and water level was measured at 1.82 m.										

Drill Method: SOLID AUGER

Drill Date: 01 FEB. 2016

Hole Size: 150 mm

FORWARD ENGINEERING

Datum: ELEV. 95.19 m

Checked by: G.S.

Sheet: 1 of 1

Project No: E5000

Project: 772 WINSTON CHURCHILL BLVD PROPERTY

Client: SORA GROUP

Location: 772 WINSTON CHURCHILL BOULEVARD, OAKVILLE, ON.

Log of Borehole: BH-110

Enclosure: 11

Technician: P.R.

SUBSURFACE PROFILE			SAMPLE			LEL %LEL				G.W.L	LAB ANALYSIS
Depth	Symbol	Description	Number	Type	Recovery	VOC Concentration ppm					
						100	200	300	400		
0		Ground Surface									
0		FILL/DISTURBED SOIL brown and grey clayey and sandy silt fill with traces of gravel, compact, wet.	1		67	NIL	15				SOIL METALS INORGANICS
1		CLAYEY SILT TILL/SHALE TILL with occasional inclusions of shale/limestone/siltstone fragments. stiff, brown, moist.	2		28	NIL	15				
2											
3		very stiff, brown and grey.	3		78	NIL	15				
4											
5		grey shale till below ±3.0 m.	4		61	NIL	16				
6											
7		-(auger grinding) transition zone to weathered shale bedrock.	5		56	NIL	15				
8											
9		WEATHERED SHALE refusal at 3.89 m. hard, grey, moist.	6			NIL	15				
10		End of Borehole at 12.75 ft									
11		Upon completion of drilling, the borehole remained open and water level was measured at 3.81 m.									
12											
13											
14											
15											

2.10 m (Feb. 29, 2016)

Drill Method: SOLID AUGER

Drill Date: 01 FEB. 2016

Hole Size: 150 mm

FORWARD ENGINEERING

Datum: ELEV. 93.65

Checked by: G.S.

Sheet: 1 of 1

**APPENDIX G
SANITARY PUMP
SPECIFICATIONS**

SF Series[®]
VARIOUS PATENTS APPLY

Submersible Pumps
Models
SFV4C SFEV4C
SFV4C-X SFEV4C-X
Size 4"



APPROVED
X-PROOF MOTORS FOR CLASS I,
DIV. 1, GROUPS C&D LOCATIONS
(X-Proof Version Only)

The Gorman-Rupp SF Series[®] vortex pumps provide superior pumping efficiency while maintaining a 3-inch (76,2 mm) spherical solids passage.

Key Features:

- NEMA premium efficiency motors
- Vortex pump technology
- Press-fit motor with finned motor housing provides superior motor cooling, even in a submersed state, resulting in increased motor life
- NEMA Class H motor insulation
- Easy, in-the-field cable changes
- Standard moisture detection in both the seal and motor chambers
- CSA-C/US and Factory Mutual (FM) Approved for Class I, Division I, Group C and D Haz Loc Applications (X-Proof Model)



Optional Accessories:

- G-R Hard Iron Impeller
- Control Panel (Consult [SF Series Motor Data Reference](#) for Customer-Supplied Control Panel)
- Submersible Transducer or Ball Type Float Switches
- Slide Rail Installation Components
 - Guide shoe ^w/Rubber Seal
 - Base Elbow and Rail Brackets
- Trash Stand Installation Components
 - Trash Stand
 - Discharge Elbow

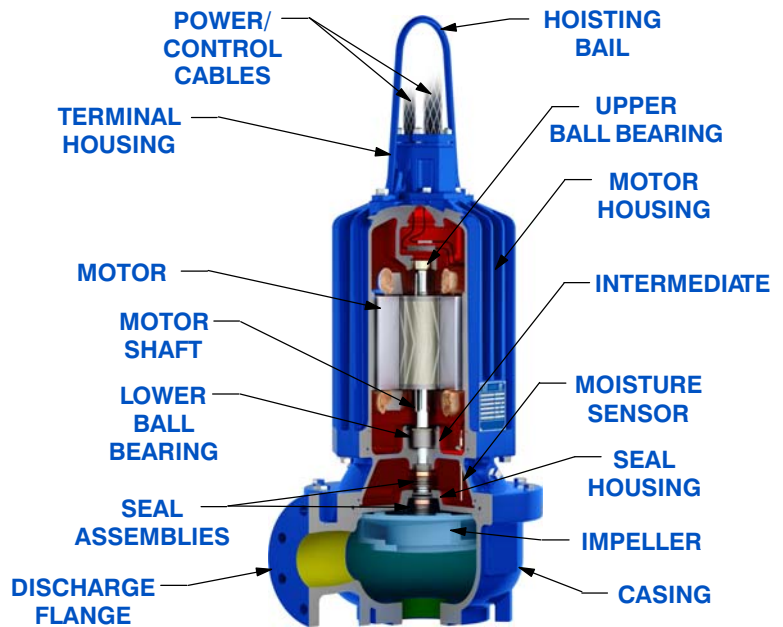

TYPICAL VORTEX CROSS-SECTION



GORMAN-RUPP PUMPS

www.grpumps.com

Specifications Subject to Change Without Notice

Printed in U.S.A.

PUMP DETAILS

Pump Models	SFV4C SFEV4C SFV4C-X SFEV4C-X	
Agency Approvals	FM/CSA-C/US	
Discharge Flange	4" ANSI w/ Flat Face	
Impeller Type	Vortex	
Impeller Material	Ductile Iron	
Spherical Solids Handling	3" (76 mm) Non-Deformable Diameter	
Motor Housing (Including Seal Plate and Intermediate)	Gray Iron 30	
Pump Casing	Gray Iron 30	
Motor Shaft	17-4 PH Stainless Steel	
O-Rings	Buna-N and Fluorocarbon (DuPont Viton® or Equivalent)	
Bearings: Type/Lubrication	Upper	Single Row Ball/Permanent Lubrication
	Lower	Double Row Ball/Permanent Lubrication
External Hardware	303/304 Stainless Steel	
External Surface Protection	Epoxy Paint	
Seal Type	Tandem, Mechanical, Oil Lubricated Upper, Self-Lubricated Lower	
Sealing Faces: Rotating/Stationary	Upper	Carbon/Ni-Resist
	Lower	Silicon Carbide/Silicon Carbide
Seal Elastomers	Buna-N Upper, Fluorocarbon (DuPont Viton® or Equivalent) Lower	
Max. Liquid Temperature	104°F (40°C)	

MOTOR DETAILS

Speed	60 Hz, 1750 RPM	
Motor Design	Inverter-Duty Rated, Air-Filled Enclosure, Squirrel Cage, Induction Start	
Motor Efficiency Rating	NEMA Premium Efficiency (IEC IE3)	
Insulation	Class H, Rated 356°F (180°C)	
Max. Submergence	65 Feet (20 Meters)	
Min. Submergence	1/2 Motor Covered	
Max. Starts per Hour	10	
Max. Rated Output Power	12.5 HP (9,3 kW)	14.0 HP (10,4 kW)
Amp Draw @ Max. Rated Power: Full Load/ Locked Rotor	208V/3P	36.6/184.7
	230V/3P	37.6/167.0
	460V/3P	18.8/83.5
	575V/3P	15.0/66.8
NEMA Motor Code	F	E
Service Factor	1.0	1.15
Efficiency: 100%/75%/50% Load	86%/87%/86%	86%/87%/87%
Power Factor: 100%/75%/50% Load	0.82/0.80/0.71	0.82/0.81/0.74
Field Connection	Across-the-Line	
Moisture Sensor	Single Probe Monitoring Both Seal and Motor Chambers	
Thermal Overload	One Thermostat per Phase, Self-Resetting	

CABLE DETAILS

Voltage		208-230/460V	575V
Power Cable	No. Cables/Conductors per	1/6	1/4
	Gauge	(3) 8 AWG PWR & (3) 10 AWG GND/GC	10 AWG
	Type/Material	GGC/CPE	SOOW/EPDM
	Nominal Cable O.D.	0.91" (23,1 mm)	0.75" (19,0 mm)
Control Cable	No. Cables/Conductors per	1/4	
	Gauge	14 AWG	
	Type/Material	SOOW/CPE	
	Nominal Cable O.D.	0.61" (15,5 mm)	
Length		32 Feet (10 Meters) Standard, 164 Feet (50 Meters) Maximum	



GORMAN-RUPP PUMPS

www.grpumps.com

Specifications Subject to Change Without Notice

Printed in U.S.A.

Specification Data

**MODELS SFV4C SFEV4C
SFV4C-X SFEV4C-X
SLIDE RAIL VERSION
APPROXIMATE
DIMENSIONS and WEIGHTS**

NET WT: (pump only)
(comb. cable wt. per meter [3.2 ft.])
SHIPPING WT: (pump only)
CRATE SIZE:

**507 LBS. [230 KG.]
2.9 LBS. [1,3 KG.]
537 LBS. [244,0 KG.]
15.3 CU. FT. [0,43 CU. M.]**

SECTION 133, PAGE 140.2

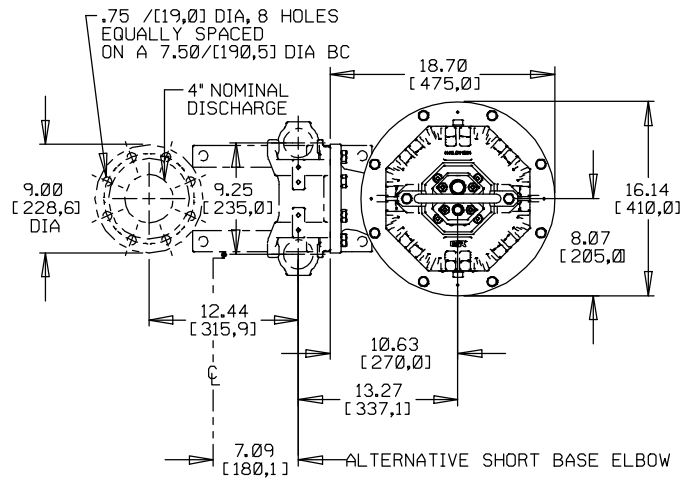

SHOWN WITH OPTIONAL
RAIL KIT AND BASE ELBOW

2" NOM PIPE SIZE
(GUIDE RAILS)
(AS SUPPLIED BY OTHERS)

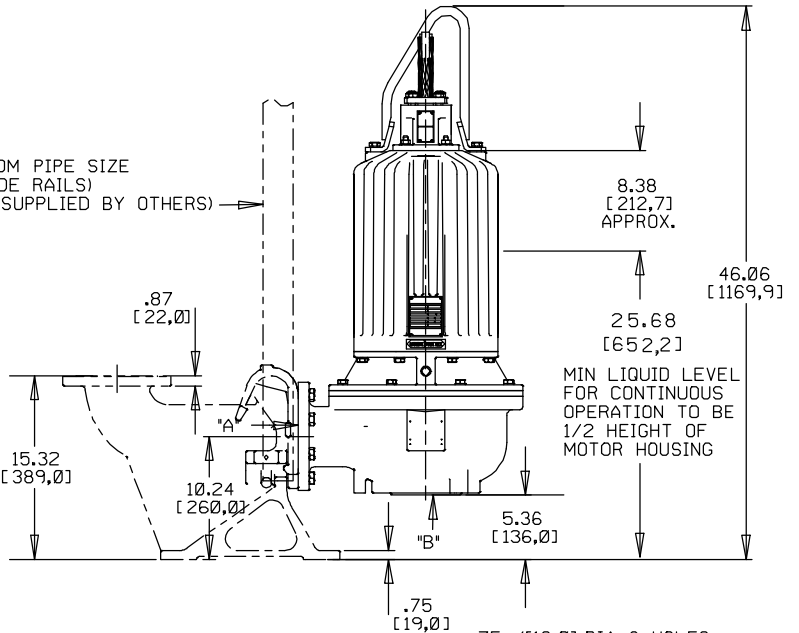

.625-11 UNC-2B, 8 PLACES
EQUALLY SPACED ON A
7.50 / [190,5] DIA BC

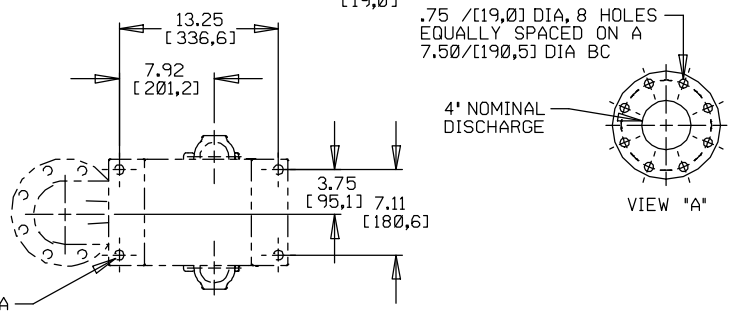
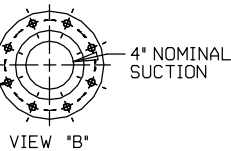

DIMENSIONS:
INCHES
(MILLIMETERS)



GORMAN-RUPP PUMPS

www.grpumps.com

Specifications Subject to Change Without Notice

Printed in U.S.A.

PERFORMANCE CURVE

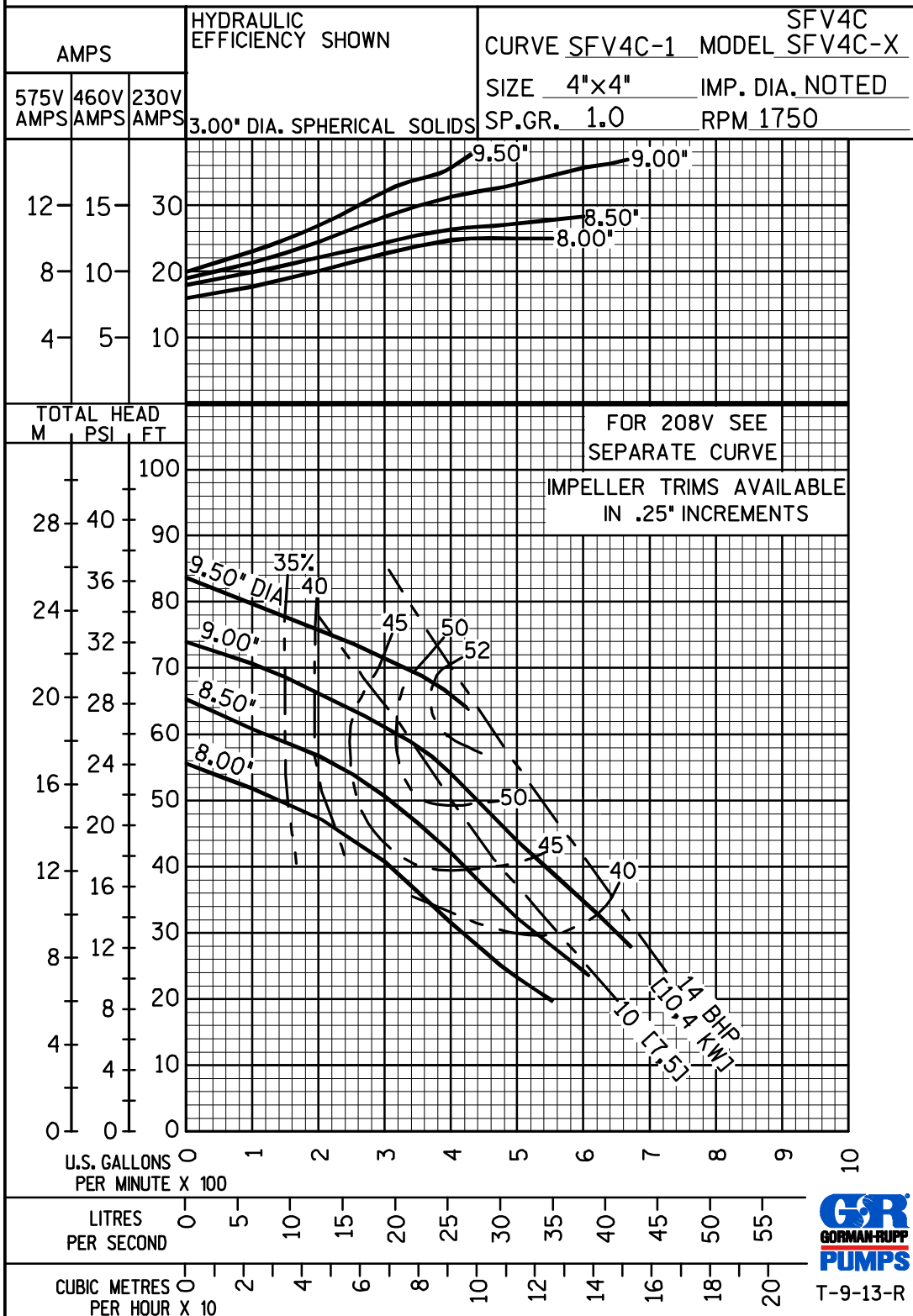

T-9-13-R



GORMAN-RUPP PUMPS

www.grpumps.com

Specifications Subject to Change Without Notice

Printed in U.S.A.

Pump Data Sheet - Gorman-Rupp SEW 60Hz

Company: JOHN BROOKS COMPANY LTD
 Name: TERENCE ALWEYN
 Date: 03/14/2021

Oakville Industrial Park- Sanitary Lift Station
 Fluid: Sewage
 Flow: 17.8 l/s
 TDH: 20 m



Pump:

Size: SFV4C-1 **Dimensions:**
 Type: SF-SERIES_STD_3PH Suction: ---
 Synch Speed: 1800 rpm Discharge: ---
 Dia: 9.25 in
 Curve: SFV4C-1

Fluid:

Name: Water
 SG: 1 Vapor Pressure: 1.77 kPa a
 Density: 999 kg/m³ Atm Pressure: 101 kPa a
 Viscosity: 1.1 cP
 Temperature: 15.6 °C Margin Ratio: 1

Search Criteria:

Flow: 17.8 l/s Near Miss: ---
 Head: 20 m Static Head: 0 m

Pump Limits:

Temperature: --- Sphere Size: 76.2 mm
 Wkg Pressure: ---

Motor:

Standard: NEMA Size: 11.2 kW
 Enclosure: TEFC Speed: 1800 rpm
 Frame: 254T
 Sizing Criteria: Max Power on Design Curve

Pump Selection Warnings:

None

--- Duty Point ---	
Flow:	18 l/s
Head:	20.5 m
Eff:	46.4%
Power:	7.77 kW
NPSHr:	---
Speed:	1750 rpm
--- Design Curve ---	
Shutoff Head:	24 m
Shutoff dP:	235 kPa
Min Flow:	--- l/s
BEP:	51.7% @ 25.6 l/s
NOL Power:	10.8 kW @ 34.7 l/s
--- Max Curve ---	
Max Power:	9.81 kW @ 26.9 l/s

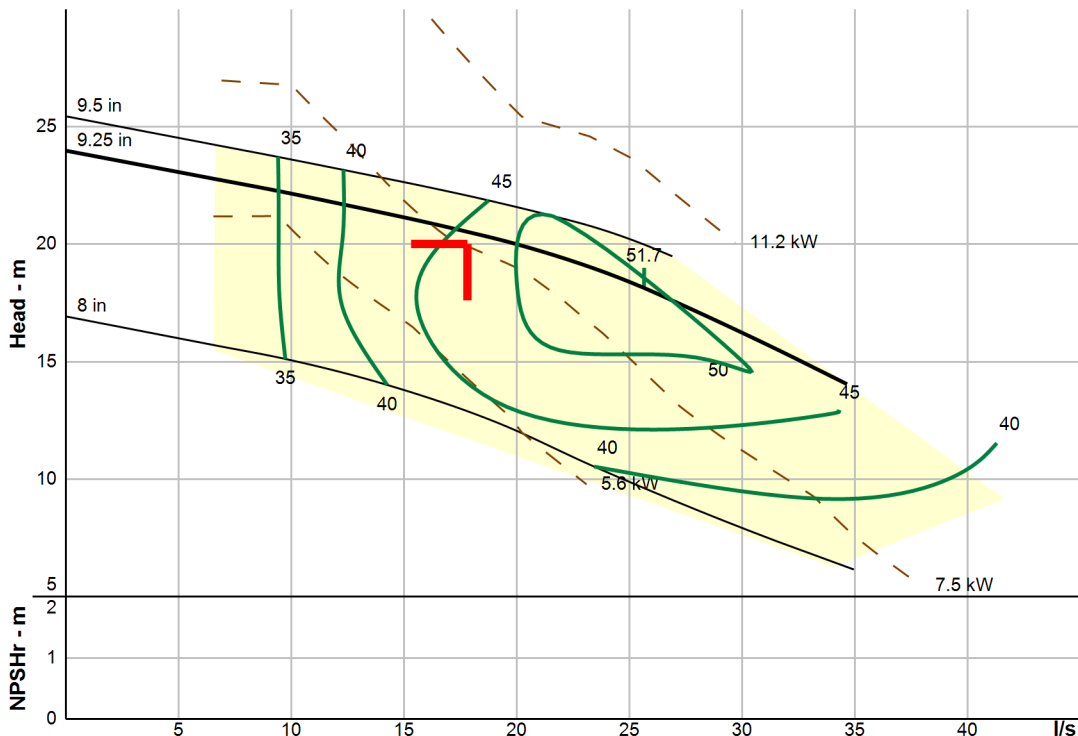

This curve is provided for preliminary selection only. Please consult factory before making final pump or motor selections.

Performance Evaluation:

Flow l/s	Speed rpm	Head m	Efficiency %	Power kW	NPSHr
21.4	1750	19.5	50	8.08	---
17.8	1750	20.5	46	7.77	---
14.2	1750	21.3	42	7.01	---
10.7	1750	22	37	6.17	---
7.12	1750	22.7	26	5.99	---



JOHN BROOKS COMPANY LIMITED

2625 Meadowpine Blvd, Mississauga, Ontario, L5N 7K5
Phone: 905-624-4200, ext. 159 Cell: 416-455-9042 Toll Free Phone: 877-624-5757
Fax: 905-624-6379
Email: talweyn@johnbrooks.ca

Sunday, March 14, 2021

Attention: Tas Candaras
A.M. CANDARAS ASSOCIATES
8551 Weston Road, Suite 203
Woodbridge, ON, L4L 9R4

T: (905) 850-8020
F: (905) 850-8099
E: tas@amcai.com

RE: Oakville Industrial Park. SANITARY STATION

Quotation Number: WQ-2103-33916191-0-TA-16628

Revision: 00

Dear Tas,

With reference to your **Oakville Industrial Park. SANITARY STATION**, we thank you for the opportunity to propose our equipment for your pumping application. Based on the information you have provided, we are pleased to submit the following proposal for a solution suitable for your application.

PERFORMANCE

Fluid: Sewage
Duty : 17.8 l/s @ 12 M
Quantity: 2 (1W+1SB)

Quantity 1 JOHN BROOKS SUBMERSIBLE PUMP PACKAGE consisting of:

1.1 PUMPS Gorman Rupp Solids Handling Vortex Electric Motor Driven Submersible Pump

- Qty 2 GORMAN RUPP FLYGT MODEL SFV4C-X SUBMERSIBLE PUMP
NEMA premium efficiency motors 14HP, 575/3/60 Inverter-Duty Rated, Air-Filled Enclosure, Squirrel Cage, Induction Start
NEMA Premium Efficiency (IEC IE3) Class H, Rated 356F (180C)
Vortex pump technology
Press-fit motor with finned motor housing provides superior motor cooling, even in a submersed state, resulting in increased motor life
NEMA Class H motor insulation
Easy, in-the-field cable changes
Standard moisture detection in both the seal and motor chambers
CSA-C/US and Factory Mutual (FM) Approved for Class I, Division I, Group C and D Haz Loc Applications
Cable length 35 M 575V, ¼ Gauge, 10AWG SOOW/EPDM
Guide Shoe X-PROOF
Control Panel Relay Kit 50284
Wet Pit Elbow Kit for Rails base plate with elbow, 36 ft. lifting cable, upper guide and mounting bracket

1.2 Tank

- Ø8' x 33' FRP Duplex Pump Station Tank to include the following:
- One (1) Ø8' FRP Dome Bottom with Skirt and flange
- One (1) Ø8' FRP Filament Wound Shell with ribs reinforcement
- One (1) Ø8' FRP Flat Top with reinforcement

PLEASE MENTION OUR QUOTATION NUMBER ON YOUR PURCHASE ORDER
"EXPERTS IN FLUID HANDLING SOLUTIONS"

- Three (3) FRP Shoebox Style Hatches
- One (1) Integral valve chamber section with dividing walls to provide water tight seal between wet well chamber and valve chamber. Valve chamber to extend from tank top to midpoint of tank
- One (1) Narrow Width Aluminum Ladder extending from tank base to the height of the tank attached to tank wall (for wet well chamber)
- One (1) Narrow Width Aluminum Ladder extending from tank top to bottom of internal valve chamber attached to tank wall (for valve chamber)
- One (1) FRP Intermediate full platform in wet well area
- One (1) Ø10" FRP Flange w/ gussets 150 PSI – 150# (Inlet 1)
- One (1) Ø10" FRP Flange w/ gussets 150 PSI – 150# (Inlet 2)
- Two (2) set of Ø4" Double Sided FRP Flange 150 PSI – 150# (wet well to dry well)
- One (1) set of Ø4" Double Sided FRP Flange 150 PSI – 150# (outlet)
- Two (2) Ø6" FRP Vent with Gooseneck & Insect Screen
- Three (3) Ø2" FRP FNPT Couplings (Electrical)
- Polymer concrete pump base (tank internal)
- Two (2) sets of 304 SS guiderail (Ø2" OD) c/w Three FRP C-channel supports
- Internal Ø4" SCH80 PVC piping c/w FRP pipe supports
- Installation of pump base elbows and internal piping with valves
- One (1) FRP Benching Bottom sloped towards pumps
- Three (3) 12" x 12" FRP Brackets for mounting Float Hanger, Junction Box, and Level sensor
- Two (2) steel lifting lugs
- One (1) Bottom Flange around FRP Skirt for bolting to concrete

1.3 Piping 4" PVC SCH80

1.4 Valves

- 4" BALLCENTRIC PLUG VALVE PRATT SERIE 601N1, ANSI 125 FLANGED CAST IRON, PRESSURE 175 PSI NICKEL SEAT, BUNA-NITRILE ELASTOMER TRIM MANUAL OPERATOR WITH HAND LEVER
- 4" FLEXIBLE DISC CHECK VALVE, PRATT SERIE 851A BODY & BONNET IN DUCTILE IRON ASTM A536-64-45-12 BUNA-N DISC, ENCAPSULATED CARBON STEEL ASTM A-36, 250PSI

1.5 Instruments (4) Float , IS

NOTE: Instruments may be shipped loose for field installation by others

1.6 Electric Control panel

- 1 EEMAC 4X painted steel, 575V/3/60, duplex, heat and seal, 15HP complete with:
- 1 Inner door
- 1 Main disconnect- non fusible
- 2 Co-ordinated motor starters
- 1 Primary and secondary fusing
- 1 Transformer
- 2 Contactors
- 1 Alternator
- 2 Heat sensor cut-outs
- Lot Terminals
- 1 Run lights
- 1 High level light
- 2 Seal leak lights
- Lot H-O-A switches
- 3 Acknowledge and test switches
- 1 Globe with flasher
- 1 Alarm horn

- 2 EHSM basic with door kit - See note #9
- 1 Four float duplex- with intrinsically safe circuitry-manual reset of the alarm
- 1 120V strip heater and thermostat
- Lot 22.5mm industrial grade LED lights
- Lot 22.5mm Operators
- Lot Dry contacts for remote alarm

2. COMMENTS

Please refer to list of exceptions/clarifications

IMPORTANT: grade elevation, inlet pipe invert elevation, top of concrete elevation, soil report to be provided with Purchase Order. JBC made number of assumptions to provide quote in timely manner. Information will be required at time of order. JBC reserves the right to revise price based on latest information provided by customer.

Installation of tanks is not included in JBC scope of work.

Antifloat concrete pedestal to be supplied and installed by others.

Anchor bolts are not included in JBC scope of work.

Electrical wiring is not in JBC scope of work

OPTIONAL ADDER

Electric Control panel with VFD

Quantity 1 EEMAC 4X stainless steel, 575V/3/60, duplex, heat and seal, 15HP complete with:

- 1 Inner door
- 1 Main disconnect- non fusible
- 2 Co-ordinated motor starters
- 1 Primary and secondary fusing
- 1 Transformer
- 2 Altivar 630 series VFDs
- 2 Altivar 630 series HIM mount and cable
- 2 5% Line reactor
- 1 Alternator
- 2 Heat sensor cut-outs
- Lot Terminals
- 2 Run lights
- 1 High level light
- 2 Seal leak lights
- 2 H-O-A switches
- 3 Acknowledge and test switches
- 1 Globe with flasher
- 1 Alarm horn
- 2 EHSM basic with door kit - See note #9
- 1 Four float duplex- with intrinsically safe circuitry-manual reset of the alarm
- 1 120V strip heater and thermostat
- 2 Circulation fans
- Lot 22.5mm industrial grade LED lights
- Lot 22.5mm Operators
- Lot Dry contacts for remote alarm