

200 SERIES

MTR-0250-00004
Legacy # MLWR250-32-ST



MANUFACTURER: Maglin
MOUNTING: Surface Mount (Refer to S/L3)
COLOUR: GUNMETAL - Fine Texture
CONTACT:
Sean Mealand
sean.mealand@maglin.com
Phone: 1 (800) 716 5506 x 1223
Cell: (226) 796 8239

DESCRIPTION: 200 Series - 250 Trash Receptacle: Heavy Duty Steel Flat Bar and H.S. Steel Frame, Metal Lid, 1 x 32 Gallon Polyethylene Liner
FINISH: All steel components are protected with E-Coat rust proofing. The Maglin Powdercoat System provides a durable finish on all metal surfaces.
INSTALLATION: The trash container is delivered pre-assembled. Holes (0.5") are provided in each mounting foot for securing to base.
TO SPECIFY: Select MTR-0250-00004
Choose:
- Powdercoat Color

HEIGHT: 35.5" (90.2cm) DIAMETER: 24.63" (62.5cm) WEIGHT: 200lbs (90kg)

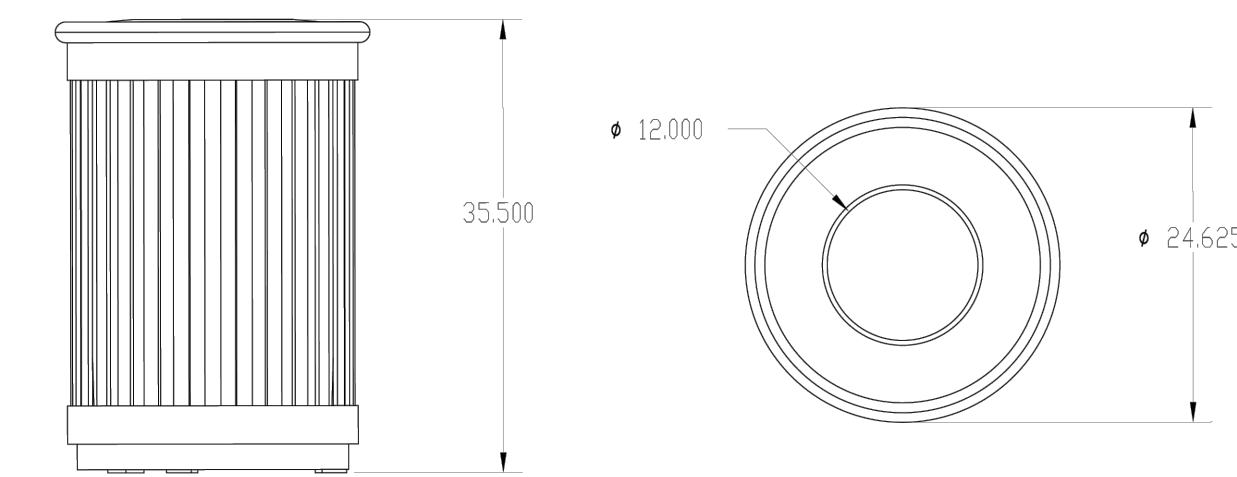

MAGLIN
Site Furniture
T 800 716 5506
F 877 260 9393
www.maglin.com
sales@maglin.com

All drawings, specifications, design and details on this page remain the property of Maglin Site Furniture Inc. and may not be used without Maglin authorization. Details and specifications may vary due to continuing improvements of our products.

Trash Receptacle
Scale N.T.S.

2
L.4

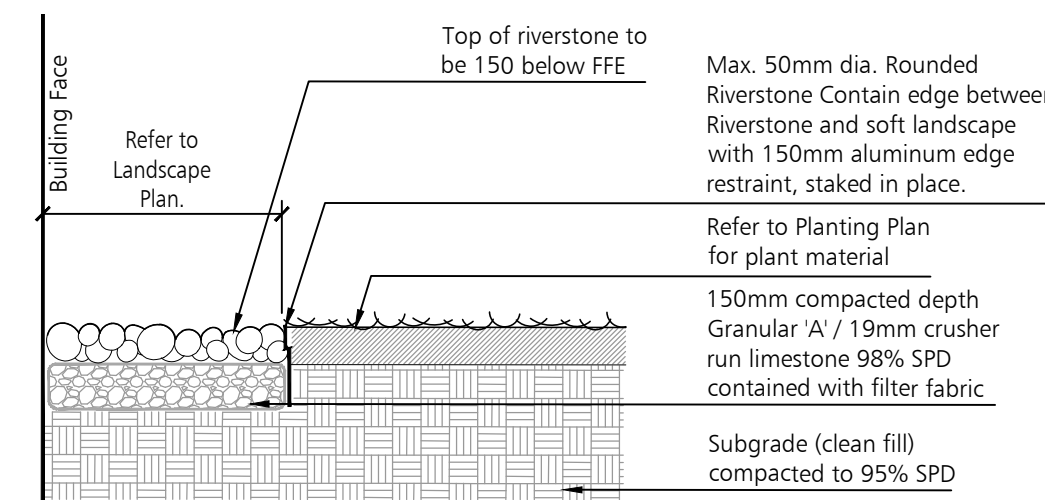

River Rock
Scale N.T.S.

100 SERIES

MBR-0150-00002
Héritage # MBR150-S



MANUFACTURER: Maglin
MOUNTING: Surface Mount (Refer to S/L3)
COLOUR: GUNMETAL - Fine Texture
CONTACT:
Sean Mealand
sean.mealand@maglin.com
Phone: 1 (800) 716 5506 x 1223
Cell: (226) 796 8239

MATERIALS: The bike rack is constructed using H.S. steel tube and steel mounting plate.
FINISH: All steel components are protected with E-Coat rust proofing. The Maglin Powdercoat System provides a durable finish on all metal surfaces.
INSTALLATION: The bike rack is delivered pre-assembled.
TO SPECIFY: Select MBR-0150-00002
Choose:
- Powdercoat Color

HEIGHT: 27.75" (70.5cm) DIAMETER: 20" (50.8cm) WEIGHT: 12.04lbs (5.5kg)

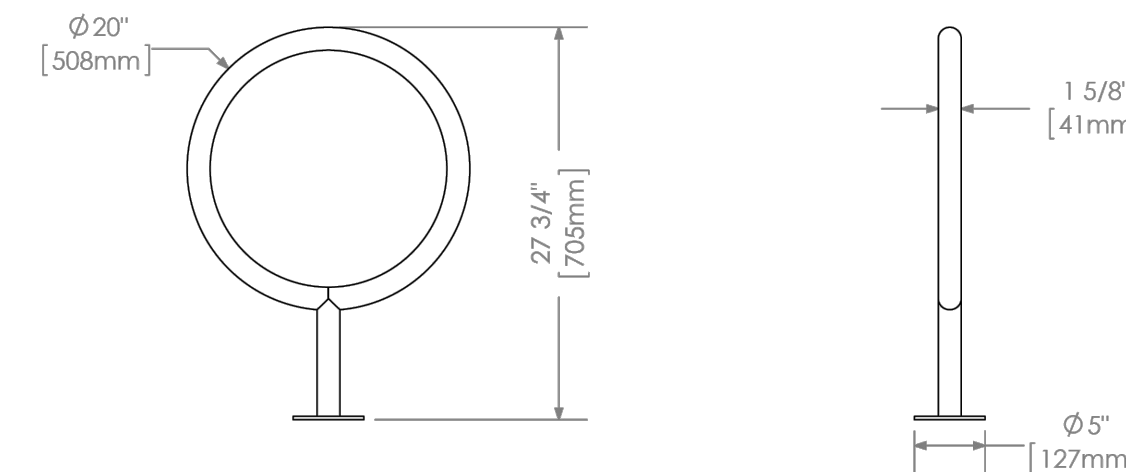

MAGLIN
Site Furniture
T 800 716 5506
F 877 260 9393
www.maglin.com
sales@maglin.com

All drawings, specifications, design and details on this page remain the property of Maglin Site Furniture Inc. and may not be used without Maglin authorization. Details and specifications may vary due to continuing improvements of our products.

Bike Ring
Scale N.T.S.

3
L.4

510 SERIES

MLPT510-S



MATERIALS: Table top and seats are made from solid steel flat bar and H.S. steel tube. Table end is wheelchair accessible.
FINISH: All steel components are protected with E-Coat rust proofing. The Maglin Powdercoat System provides a durable finish on all metal surfaces.
INSTALLATION: The table is delivered pre-assembled.
TO SPECIFY: Select MLPT510-S
Choose:
- Powdercoat color

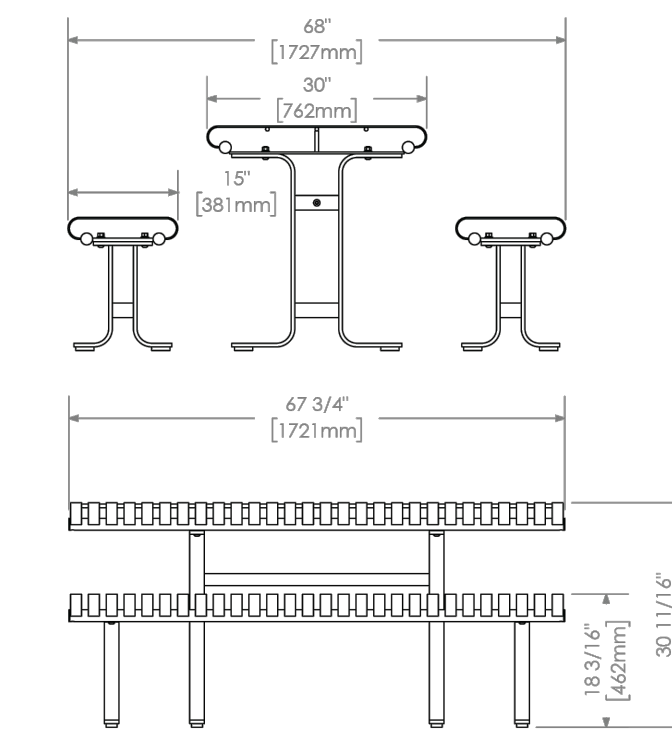

MANUFACTURER: Maglin
MOUNTING: Surface Mount (Refer to S/L3)
COLOUR: GUNMETAL - Fine Texture
CONTACT:
Sean Mealand
sean.mealand@maglin.com
Phone: 1 (800) 716 5506 x 1223
Cell: (226) 796 8239

DIMENSIONS:
Table Height: 30.69" (779cm)
Table Length: 67.75" (172.1cm)
Total Width: 68.20" (173.2cm)
Weight: 372.28lb (169 kg)

MAGLIN
Site Furniture
T 800 716 5506
F 877 260 9393
www.maglin.com
sales@maglin.com

All drawings, specifications, design and details on this page remain the property of Maglin Site Furniture Inc. and may not be used without Maglin authorization. Details and specifications may vary due to continuing improvements of our products.

Picnic Table
Scale N.T.S.

1
L.4

Note: All Drawings by Baker Turner inc. to be Printed in Colour.

REVISIONS

May 05, 23	Issued for SPA
Apr 04, 23	Re-Issued for Submission
Dec 22, 22	Re-Issued for Submission
Dec 16, 22	Re-Issued for Submission
Aug 24, 22	Re-Issued for Submission
Aug 23, 22	Re-Issued for Submission
Aug 19, 22	Re-Issued for Submission
Aug 10, 22	Issued for Submission
Apr 12, 22	Issued for Submission

DATE DESCRIPTION

NOTE: Contractor is to check and verify all dimensions and conditions on the project, and is to immediately report any discrepancies to the landscape architect before proceeding with the work.

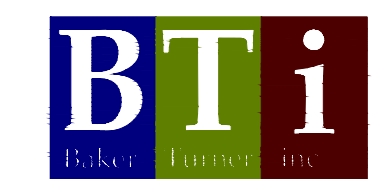

Landscape Architecture | Site Design
Suite 224
2010 Winston Park Drive
Oakville Ontario L6H 5R7
Tel: (289) 291-7620
email: tba@bakerturner.com

Project Title

Burloak Industrial
835 Burloak Drive & 3540 Wyecroft Road
Oakville, ON

DETAILS & SPECIFICATIONS

Date	Issued
March 2022	
Job Number	Drawn By
BTI-1605	
Scale	Checked By
As Shown	MT
Sheet Number	File Number
L4 of 4	FILE NO.

NOT FOR CONSTRUCTION