

PART 1 OF 4  
SHEET 1 OF 3

HALTON STANDARD  
CONDOMINIUM PLAN No.

INDEX OF PARTS		
PART	NUMBER OF SHEETS	DESCRIPTION
1	3	PLAN OF SURVEY OF THE CONDOMINIUM PROPERTY ILLUSTRATING SERVIENT INTERESTS AND THE DESIGNATION OF UNITS ON LEVEL 1 AND 2
2	1	PLAN OF SURVEY OF THE EXTENT AND LOCATION OF THE EXCLUSIVE USE PORTIONS OF THE COMMON ELEMENTS ON LEVEL 1
3	XX	ARCHITECTURAL PLANS
4	XX	STRUCTURAL PLANS

LEVEL 1  
UNITS 1 TO 25 (BOTH INCLUSIVE)

REGISTERED IN THE LAND REGISTRY OFFICE FOR THE LAND TITLES DIVISION OF HALTON (No. 20) AT \_\_\_\_\_ O'CLOCK ON THE \_\_\_\_\_ DAY OF \_\_\_\_\_ 20\_\_\_\_

REPRESENTATIVE FOR THE LAND REGISTRAR FOR THE LAND TITLES DIVISION OF HALTON (No. 20)

PLAN OF SURVEY OF  
PART OF BLOCK 2  
REGISTERED PLAN 20M-1171  
TOWN OF OAKVILLE  
REGIONAL MUNICIPALITY OF HALTON

SCALE 1: 400



David B. Scarles Surveying Ltd.  
ONTARIO LAND SURVEYORS

METRIC  
DISTANCES AND COORDINATES SHOWN ON THIS PLAN ARE IN METRES AND CAN BE CONVERTED TO FEET BY DIVIDING BY 0.3048

SURVEYOR'S CERTIFICATE

- I CERTIFY THAT:
- THIS SURVEY AND PLAN ARE CORRECT AND IN ACCORDANCE WITH THE SURVEYORS ACT, THE SURVEYORS ACT, THE LAND TITLES ACT, AND THE CONDOMINIUM ACT, 1998 AND THE REGULATIONS MADE UNDER THEM.
  - THE SURVEY WAS COMPLETED ON THE \_\_\_\_\_ DAY OF \_\_\_\_\_
  - THE DIAGRAMS OF THE UNITS SHOWN ON THIS PLAN ARE SUBSTANTIALLY ACCURATE.

DATE \_\_\_\_\_ BONEY CHERIAN  
ONTARIO LAND SURVEYOR

DECLARATION REGISTERED AS No.

THIS PLAN IS COMPRISED OF ALL OF PIN 24890-0439(LT)

SCHEDULE OF APPURTENANT AND SERVIENT INTERESTS  
PURSUANT TO CLAUSES 8(1), (9) AND (10) OF THE CONDOMINIUM ACT, 1998

TOGETHER WITH (APPURTENANT INTERESTS)	PART	PLAN	DESCRIBED IN	NOTES
	NIL			
SUBJECT TO (SERVIENT INTERESTS)	PART 1	20R-21410	HR1436680	
	PART 1	20R-21410	HR1338374	

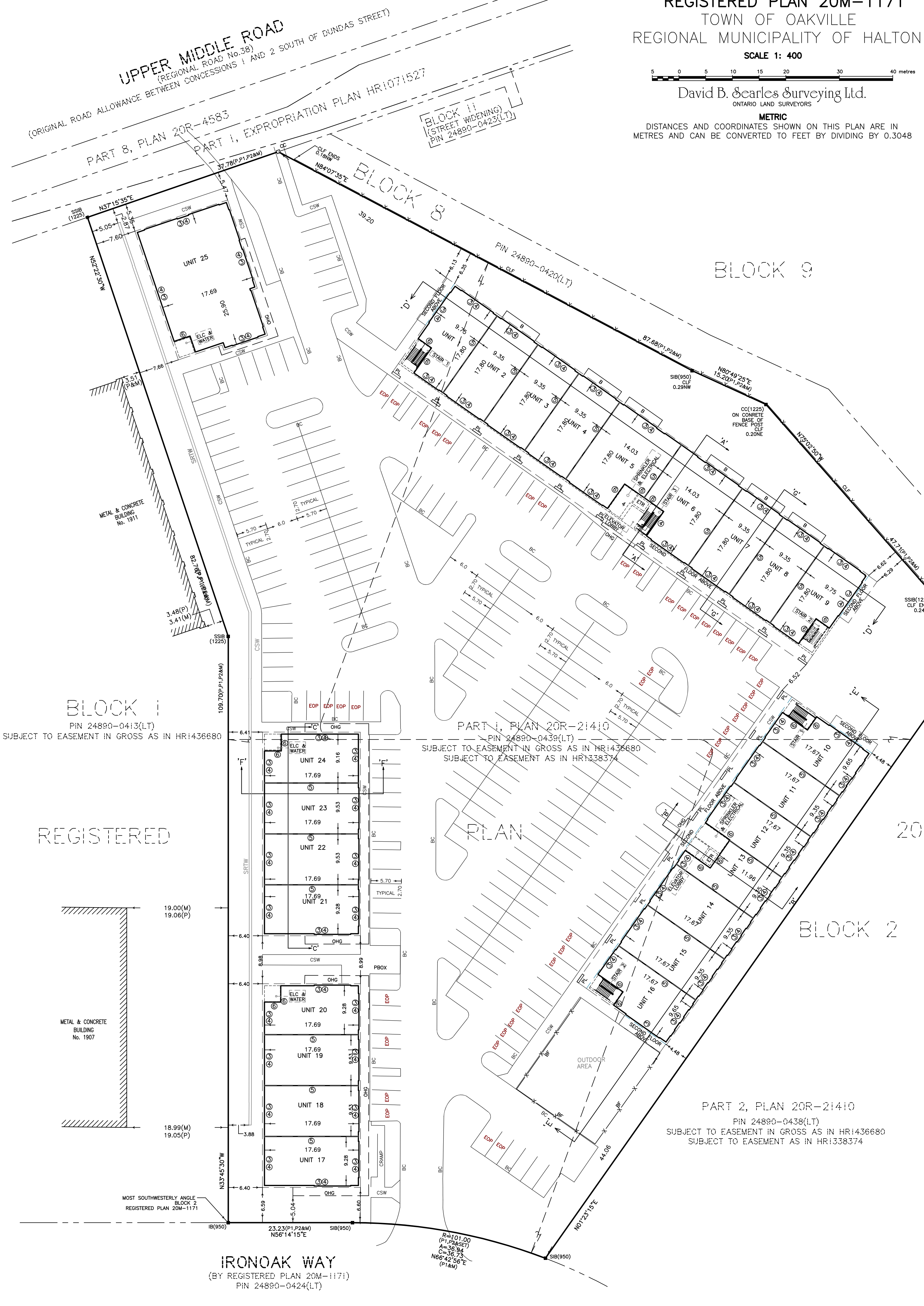

**LEGEND**

- DENOTES MONUMENT FOUND
- DENOTES MONUMENT SET
- CC DENOTES CUT CROSS
- IB DENOTES IRON BAR
- SIB DENOTES STANDARD IRON BAR
- SSIB DENOTES SHORT STANDARD IRON BAR
- 950 DENOTES CUNNINGHAM MCCONNELL LTD., O.L.S.
- 1225 DENOTES DAVID B. SCARLES SURVEYING LTD., O.L.S.
- M DENOTES MEASURED
- P DENOTES SURVEYOR'S REAL PROPERTY REPORT BY NANFARA & NG SURVEYORS INC. DATED SEPTEMBER 13, 2017 (W.O. 20160757P1)
- P1 DENOTES REGISTERED PLAN 20M-1171
- P2 DENOTES REGISTERED PLAN 20M-1171
- B DENOTES BALCONY
- CLF DENOTES CHAIN LINK FENCE
- EOP DENOTES EXCLUSIVE USE PARKING
- ETR DENOTES ELEVATOR
- ETC DENOTES ELECTRICAL
- OHG DENOTES OVERHANG
- PL DENOTES PILLAR
- SRTW DENOTES STONE RETAINING WALL
- DENOTES BOUNDARY OF THE UNITS

**INTEGRATION DATA**

SPECIFIED CONTROL POINT No.	NORTHING	EASTING
SCP 48	48	48
SCP 48	48	48

COORDINATES CANNOT, IN THEMSELVES, BE USED TO RE-ESTABLISH CORNERS OR BOUNDARIES SHOWN ON THIS PLAN.

**BEARING NOTE**  
BEARINGS SHOWN HEREON ARE GRID BEARINGS DERIVED FROM SPECIFIED CONTROL POINTS AND REFERRED TO UTM ZONE 17, NAD83 (ORIGINAL).

**DISTANCE NOTE**  
DISTANCES SHOWN HEREON ARE GROUND DISTANCES AND CAN BE CONVERTED TO GRID DISTANCES BY MULTIPLYING BY A COMBINED SCALE FACTOR OF 0.999725.

**NOTE**  
PROPERTY LIMITS ARE NOT FENCED UNLESS OTHERWISE NOTED ON THE FACE OF THE PLAN.

**MUNICIPAL APPROVAL:**  
PARTS 1 AND 2 APPROVED AND PARTS 3 AND 4 EXEMPTED UNDER SECTION 9 OF THE CONDOMINIUM ACT, 1998, S.O. 1998, c. 19 AND SECTION 51 OF THE PLANNING ACT, R.S.O. 1990, c. F.13, AS AMENDED.

DATED THIS \_\_\_\_\_ DAY OF \_\_\_\_\_ 20\_\_\_\_

NAME \_\_\_\_\_  
COMMISSIONER  
PLANNING AND BUILDING DEPARTMENT  
TOWN OF OAKVILLE

**CERTIFICATE OF DECLARANT**  
THIS IS TO CERTIFY THAT:  
THE PROPERTY INCLUDED IN THIS PLAN HAS BEEN LAID OUT INTO UNITS AND COMMON ELEMENTS IN ACCORDANCE WITH OUR INSTRUCTIONS.

**DECLARANT:**  
DATED AT \_\_\_\_\_ THIS \_\_\_\_\_ DAY OF \_\_\_\_\_ 20\_\_\_\_

NAME \_\_\_\_\_  
I HAVE AUTHORITY TO BIND THE CORPORATION

David B. Scarles Surveying Ltd. ONTARIO LAND SURVEYORS 4255 Sherwoodtowne Blvd., Suite 206, Mississauga, Ontario L4Z 1Y1 Tel: (905) 273-6840 Fax: (905) 896-4410 Email: info@dbscarles.ca	Calculator BJ	Draftsperson PG
Editor BJ	Plan Index No. R 19	
Calculation File 26-21CALC.DWG	Drawing File 26-4-21.DWG	File No. 26-4-21

- UNIT BOUNDARY DEFINITIONS**
- AREAS NOT DESIGNATED AS UNITS ARE COMMON ELEMENTS.
- ① DENOTES HORIZONTAL PLANE ESTABLISHED BY UPPER SURFACE OF CONCRETE FLOOR SLAB AND PRODUCTION THEREOF
  - ② DENOTES HORIZONTAL PLANE ESTABLISHED BY UNIT SIDE LOWER SURFACE OF ROOF TRUSSES AND/OR BEAMS AND PRODUCTION THEREOF
  - ③ DENOTES VERTICAL PLANE ESTABLISHED BY FINISHED EXTERIOR SURFACE OF EXTERIOR DOOR AND DOOR FRAMES, WINDOWS AND WINDOW FRAMES, THE SAID DOORS AND WINDOWS IN CLOSED POSITION, AND THE EXTERIOR OR OUTSIDE SURFACE OF ALL GLASS PANELS CONTAINED THEREIN.
  - ④ DENOTES VERTICAL PLANE ESTABLISHED BY THE BACKSIDE FACE OF DRYWALL AND PRODUCTION THEREOF.
  - ⑤ DENOTES VERTICAL PLANE ESTABLISHED BY CENTRELINE OF DEMISING WALLS AND PRODUCTION THEREOF
  - ⑥ DENOTES VERTICAL PLANE ESTABLISHED BY UNFINISHED EXTERIOR SURFACE OF CONCRETE FOUNDATION WALL AND PRODUCTION THEREOF.
  - DENOTES BOUNDARIES OF UNITS
  - DENOTES STRUCTURAL LIMITS



LEVEL 2  
UNITS 1 TO 16 (BOTH INCLUSIVE)

LEVEL 2  
UNITS 1 TO 16 (BOTH INCLUSIVE)

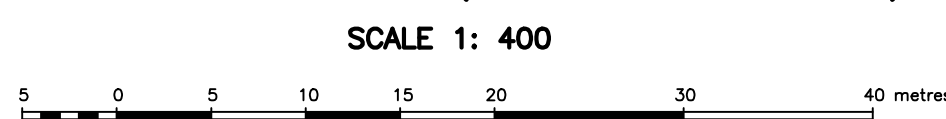

David B. Searles Surveying Ltd.  
ONTARIO LAND SURVEYORS

METRIC  
DISTANCES AND COORDINATES SHOWN ON THIS PLAN ARE IN METRES AND CAN BE CONVERTED TO FEET BY DIVIDING BY 0.3048

REGISTERED IN THE LAND REGISTRY OFFICE FOR THE LAND TITLES DIVISION  
OF HALTON (No. 20) AT \_\_\_\_\_ O'CLOCK ON THE \_\_\_\_\_ DAY OF  
\_\_\_\_\_, 20\_\_\_\_.

REPRESENTATIVE FOR THE LAND REGISTRAR  
FOR THE LAND TITLES DIVISION OF HALTON (No. 20)

SURVEYOR'S CERTIFICATE

- I CERTIFY THAT:
1. THIS SURVEY AND PLAN ARE CORRECT AND IN ACCORDANCE WITH THE ACT, THE SURVEYORS ACT, THE LAND TITLES ACT, AND THE CONDOMINIUM ACT, 1998 AND THE REGULATIONS MADE UNDER THEM.
  2. THE SURVEY WAS COMPLETED ON THE \_\_\_\_ DAY OF \_\_\_\_\_, 20\_\_\_\_.
  3. THE DIAGRAMS OF THE UNITS SHOWN ON THIS PLAN ARE SUBSTANTIALLY ACCURATE.

DATE \_\_\_\_\_ BONEY CHERIAN  
ONTARIO LAND SURVEYOR

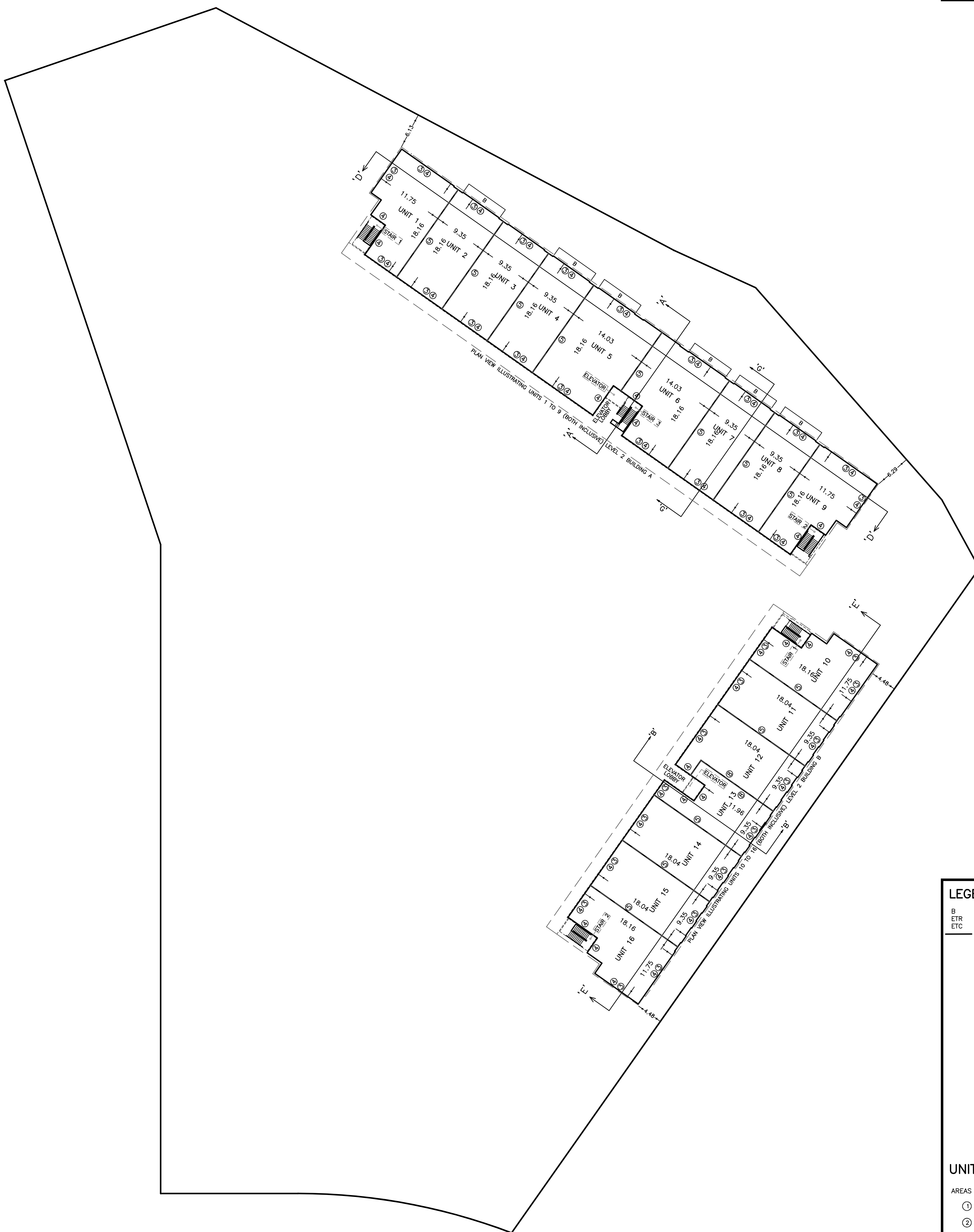

LEGEND

- B DENOTES BALCONY
- ETR DENOTES ELEVATOR
- ETC DENOTES ELECTRICAL
- DENOTES BOUNDARY OF THE UNITS

UNIT BOUNDARY DEFINITIONS

AREAS NOT DESIGNATED AS UNITS ARE COMMON ELEMENTS.

- ① DENOTES HORIZONTAL PLANE ESTABLISHED BY UPPER SURFACE OF CONCRETE FLOOR SLAB AND PRODUCTION THEREOF
- ② DENOTES HORIZONTAL PLANE ESTABLISHED BY UNIT SIDE LOWER SURFACE OF ROOF TRUSSES AND/OR BEAMS AND PRODUCTION THEREOF
- ③ DENOTES VERTICAL PLANE ESTABLISHED BY FINISHED EXTERIOR SURFACE OF EXTERIOR DOOR AND DOOR FRAMES, WINDOWS AND WINDOW FRAMES, THE SAID DOORS AND WINDOWS IN CLOSED POSITION, AND THE EXTERIOR OR OUTSIDE SURFACE OF ALL GLASS PANELS CONTAINED THEREIN.
- ④ DENOTES VERTICAL PLANE ESTABLISHED BY THE BACKSIDE FACE OF DRYWALL AND PRODUCTION THEREOF.
- ⑤ DENOTES VERTICAL PLANE ESTABLISHED BY CENTRELINE OF DEMISING WALLS AND PRODUCTION THEREOF.
- ⑥ DENOTES VERTICAL PLANE ESTABLISHED BY UNFINISHED EXTERIOR SURFACE OF CONCRETE FOUNDATION WALL AND PRODUCTION THEREOF.
- DENOTES BOUNDARIES OF UNITS
- - - DENOTES STRUCTURAL LIMITS

CERTIFICATE OF DECLARANT

THIS IS TO CERTIFY THAT:  
THE PROPERTY INCLUDED IN THIS PLAN HAS BEEN LAID OUT INTO UNITS AND COMMON ELEMENTS IN ACCORDANCE WITH OUR INSTRUCTIONS.

DECLARANT:

DATED AT \_\_\_\_\_ THIS \_\_\_\_ DAY OF \_\_\_\_\_, 20\_\_\_\_.

NAME \_\_\_\_\_  
I HAVE AUTHORITY TO BIND THE CORPORATION

David B. Searles Surveying Ltd.  
ONTARIO LAND SURVEYORS  
4255 Sherwoodstone Blvd., Suite 206, Mississauga, Ontario L4Z 1Y5  
Tel: (905) 273-6840 Fax: (905) 896-4410  
Email: info@dbsearles.co

Calculator	Draftsperson
BJ	PC
Editor	Plan Index No
BC/BJ	R 16

Calculation File	Drawing File	File No.
26-21CALC.DWG	26-4A-21.DWG	26-4A-21



PLAN OF SURVEY OF  
THE EXTENT AND LOCATION OF  
THE EXCLUSIVE USE PORTIONS OF THE COMMON ELEMENTS  
LEVEL 1

SCALE 1: 400

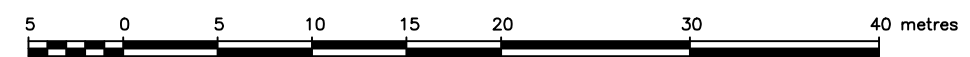

David B. Searles Surveying Ltd.  
ONTARIO LAND SURVEYORS

METRIC  
DISTANCES AND COORDINATES SHOWN ON THIS PLAN ARE IN METRES AND CAN BE CONVERTED TO FEET BY DIVIDING BY 0.3048

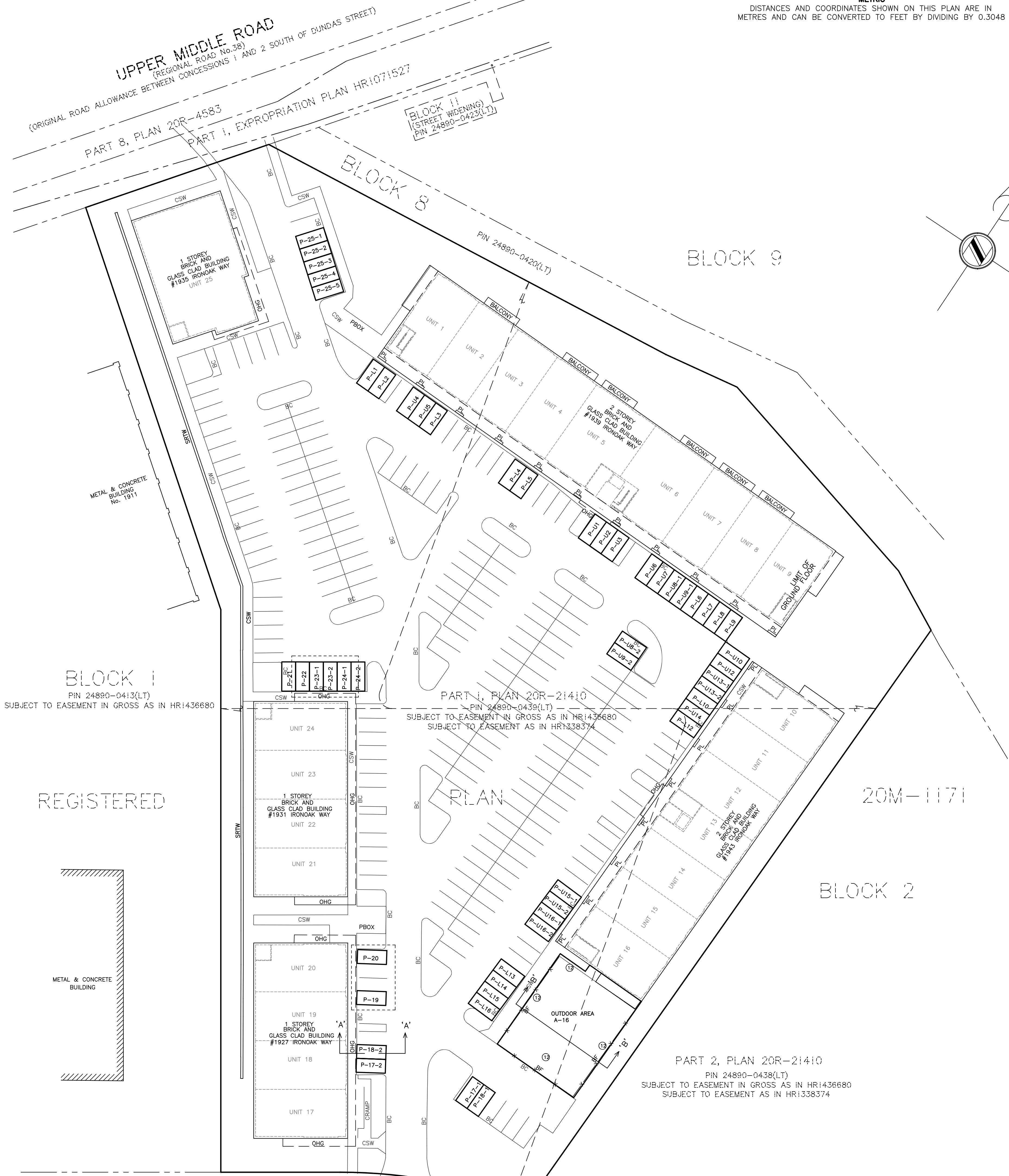
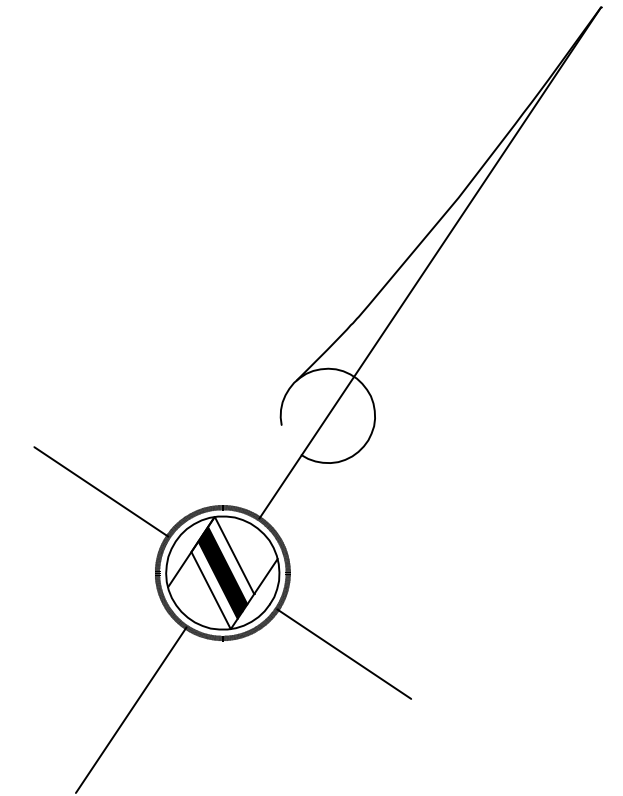

REGISTERED

20M-1171

BLOCK 2

IRONOAK WAY  
(BY REGISTERED PLAN 20M-1171)  
PIN 24880-0424(LT)

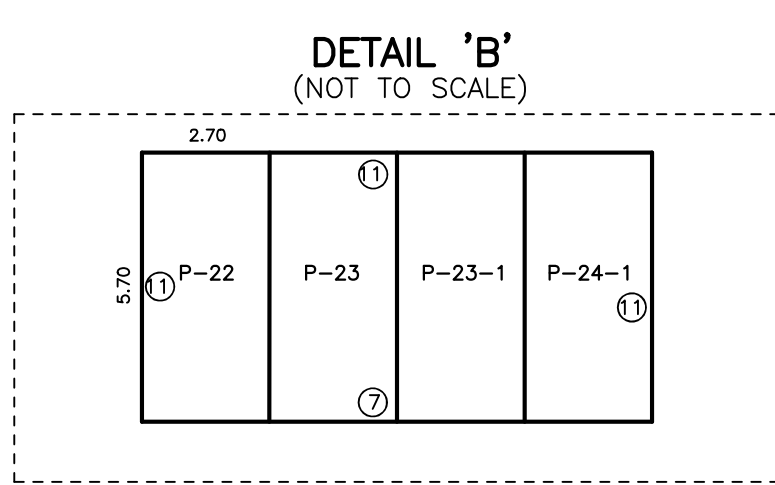
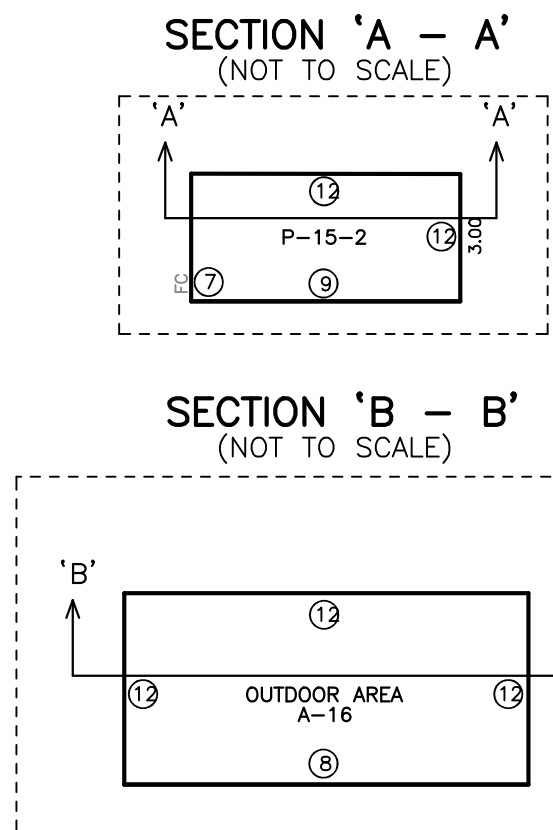
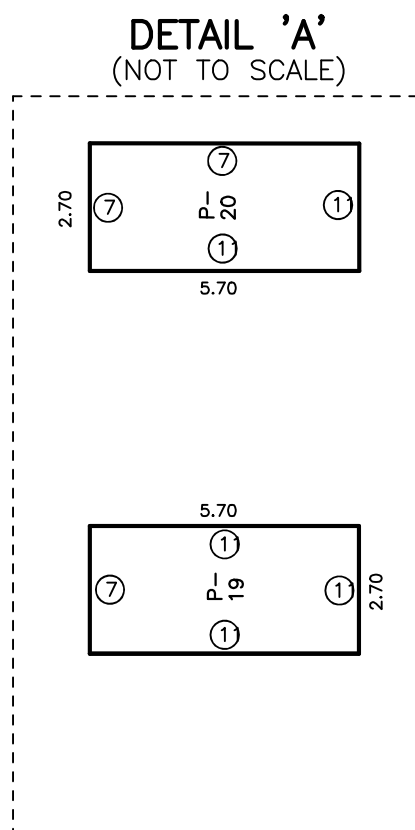

- UNIT BOUNDARY DEFINITIONS**
- BOUNDARIES OF EXCLUSIVE USE PORTIONS ARE AS FOLLOWS:
- ⑦ DENOTES THE HORIZONTAL PLANE ESTABLISHED BY THE FACE OF THE CONCRETE CURB.
  - ⑧ DENOTES THE VERTICAL PLANE ESTABLISHED BY THE TOP OF SOD.
  - ⑨ DENOTES THE VERTICAL PLANE ESTABLISHED BY THE TOP COAT OF ASPHALT.
  - ⑩ DENOTES THE HORIZONTAL PLANE ESTABLISHED BY CENTRELINE OF THE CHAIN LINK FENCE.
  - ⑪ DENOTES THE HORIZONTAL PLANE ESTABLISHED BY MEASUREMENT.
  - ⑫ DENOTES THE VERTICAL PLANE ESTABLISHED BY MEASUREMENT.
  - CSW DENOTES CONCRETE SIDEWALK
  - EOP DENOTES EXCLUSIVE USE PARKING
  - FC DENOTES FACE OF CURB
  - BC DENOTES BOUNDARIES OF UNITS
  - DENOTES STRUCTURAL LIMITS

**SURVEYOR'S CERTIFICATE**

I CERTIFY THAT THIS PLAN OF SURVEY ACCURATELY SHOWS THE EXTENT AND LOCATION OF THE EXCLUSIVE USE PORTIONS OF THE COMMON ELEMENTS.

DATE \_\_\_\_\_ BONEY CHERIAN  
ONTARIO LAND SURVEYOR

David B. Searles Surveying Ltd.		Calculator	Draftsperson
ONTARIO LAND SURVEYORS		BU	PC
4255 Sherwoodlane Blvd., Suite 206, Mississauga, Ontario L4Z 1Y5		Editor	Plan Index No.
Tel: (905) 273-6840 Fax: (905) 896-4410		BC/BJ	R 16
Email: info@dbsearles.co		File No.	
Calculation File	Drawing File	File No.	
26-21CALC.DWG	26-4B-21.DWG	26-4B-21	



SCALE 1: 400



David B. Scarles Surveying Ltd.  
ONTARIO LAND SURVEYORS

METRIC  
DISTANCES AND COORDINATES SHOWN ON THIS PLAN ARE IN METRES AND CAN BE CONVERTED TO FEET BY DIVIDING BY 0.3048

LEVEL 1  
UNITS 1 TO 25 (BOTH INCLUSIVE)  
LEVEL 2  
UNITS 10 TO 16 (BOTH INCLUSIVE)

REGISTERED IN THE LAND REGISTRY OFFICE FOR THE LAND TITLES DIVISION OF HALTON (No. 20) AT \_\_\_\_\_ O'CLOCK ON THE \_\_\_\_\_ DAY OF \_\_\_\_\_ 20\_\_\_\_.

REPRESENTATIVE FOR THE LAND REGISTRAR FOR THE LAND TITLES DIVISION OF HALTON (No. 20)

**SURVEYOR'S CERTIFICATE**

I CERTIFY THAT:  
1. THIS SURVEY AND PLAN ARE CORRECT AND IN ACCORDANCE WITH THE ACT, THE SURVEYORS ACT, THE LAND TITLES ACT, AND THE CONDOMINIUM ACT, 1998 AND THE REGULATIONS MADE UNDER THEM.  
2. THE SURVEY WAS COMPLETED ON THE \_\_\_\_\_ DAY OF \_\_\_\_\_  
3. THE DIAGRAMS OF THE UNITS SHOWN ON THIS PLAN ARE SUBSTANTIALLY ACCURATE.

DATE \_\_\_\_\_ BONEY CHERIAN  
ONTARIO LAND SURVEYOR

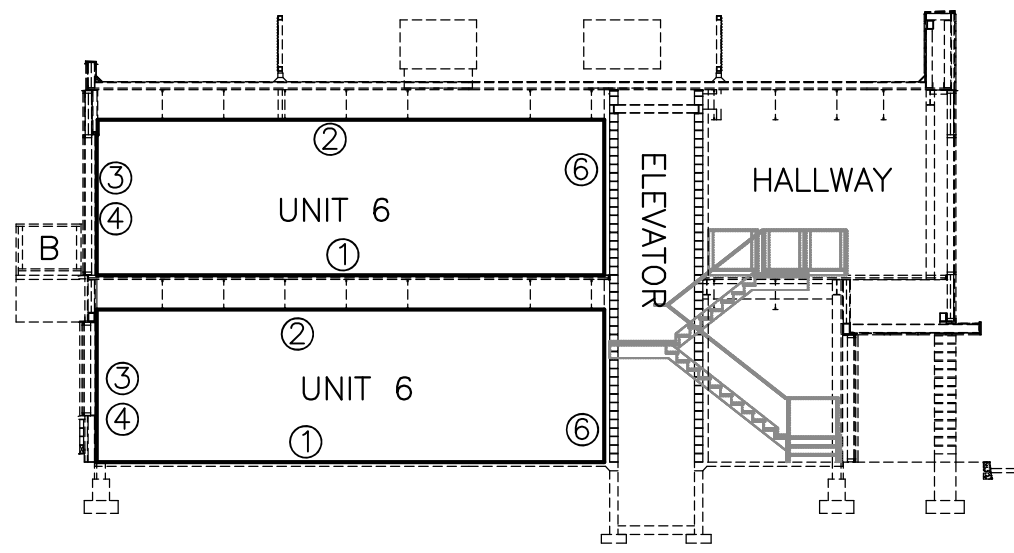
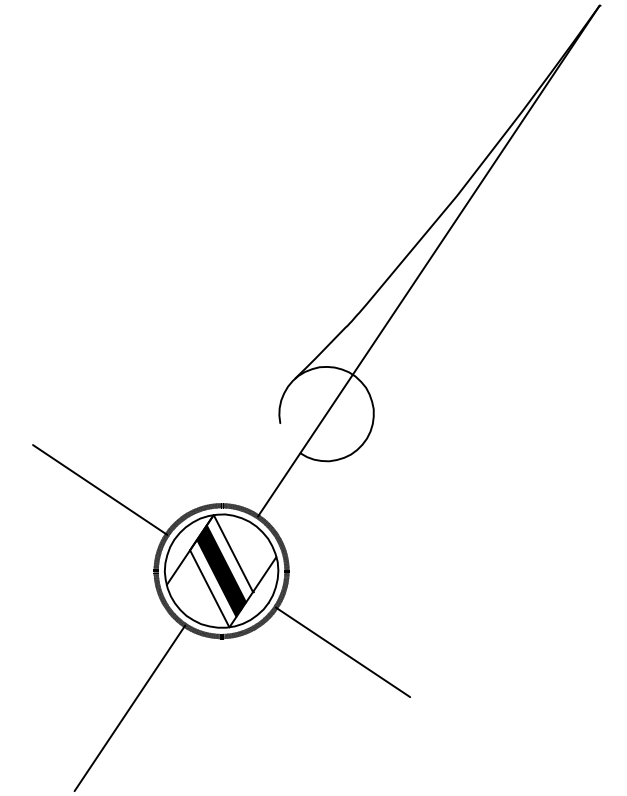

SECTION 'A'-A'  
SECTION ILLUSTRATING RELATIONSHIP BETWEEN LEVELS 1 AND 2 BUILDING A (NOT TO SCALE)

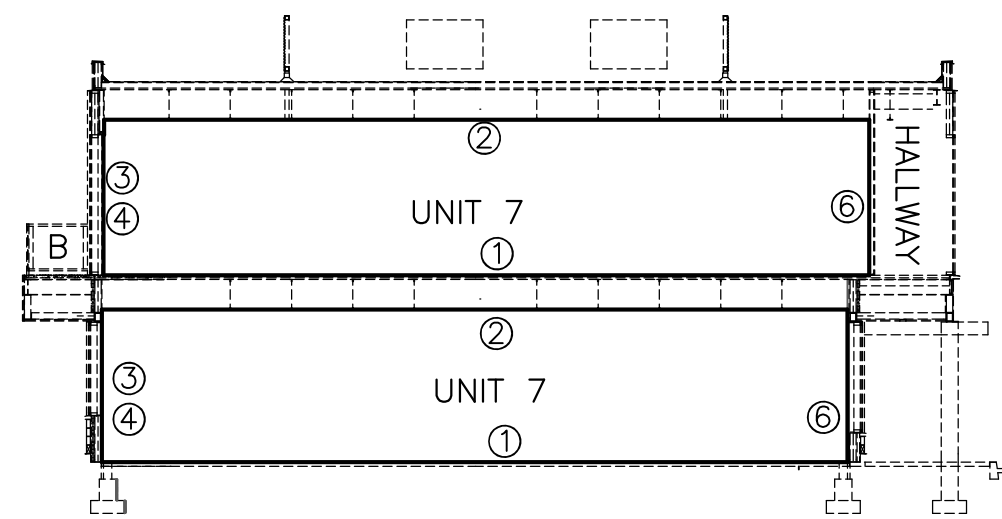

SECTION 'G'-G'  
SECTION ILLUSTRATING RELATIONSHIP BETWEEN LEVELS 1 AND 2 BUILDING A (NOT TO SCALE)

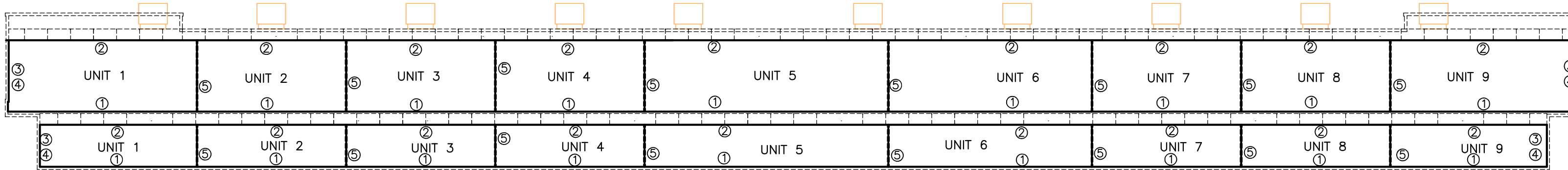

SECTION 'D'-D'  
SECTION ILLUSTRATING RELATIONSHIP BETWEEN LEVELS 1 AND 2 BUILDING A (NOT TO SCALE)

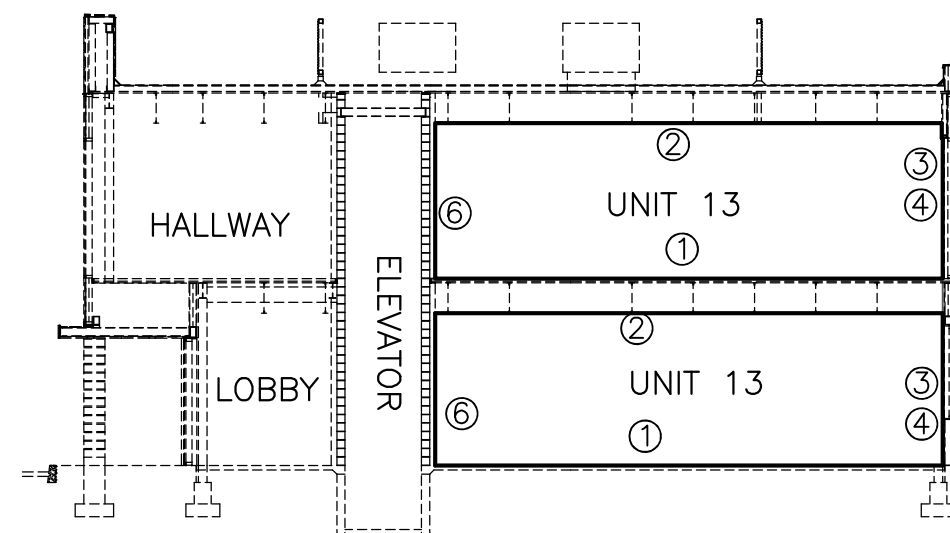

SECTION 'B'-B'  
SECTION ILLUSTRATING RELATIONSHIP BETWEEN LEVELS 1 AND 2 BUILDING B (NOT TO SCALE)

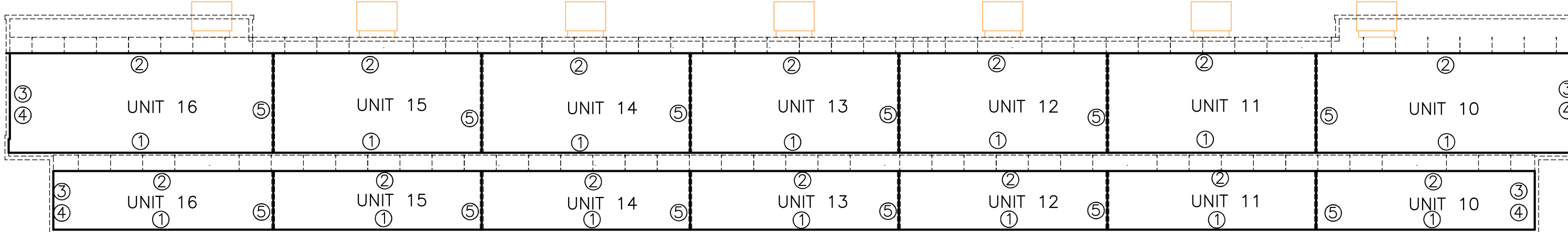

SECTION 'E'-E'  
SECTION ILLUSTRATING RELATIONSHIP BETWEEN LEVELS 1 AND 2 BUILDING B (NOT TO SCALE)

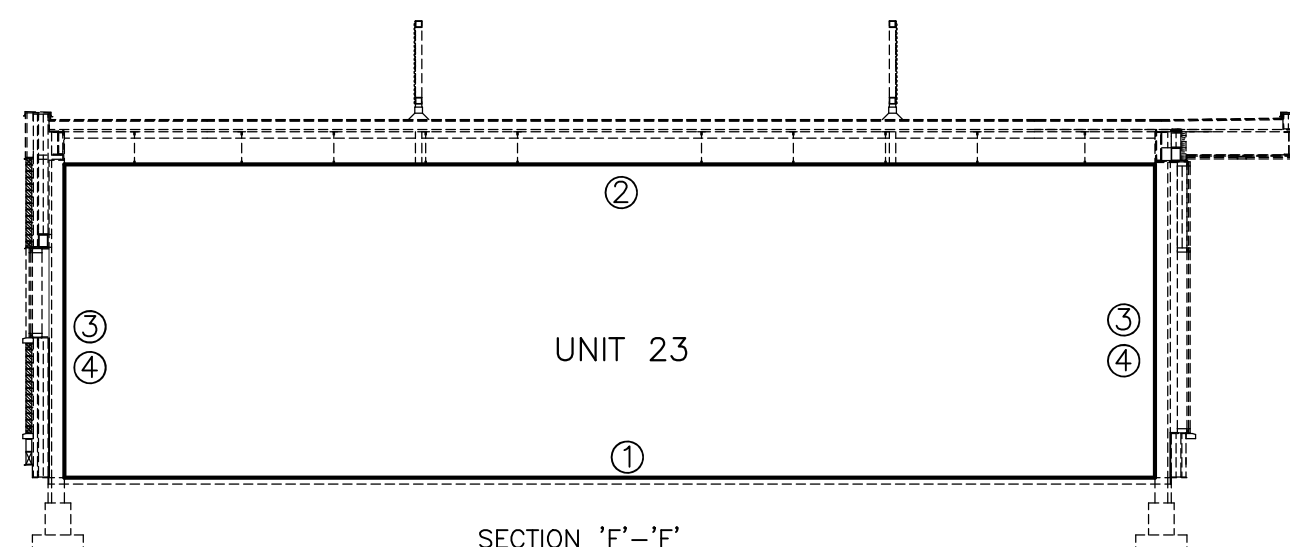

SECTION 'F'-F'  
SECTION ILLUSTRATING TYPICAL UNIT BOUNDARIES UNITS 17 TO 24 (BOTH INCLUSIVE) (NOT TO SCALE)

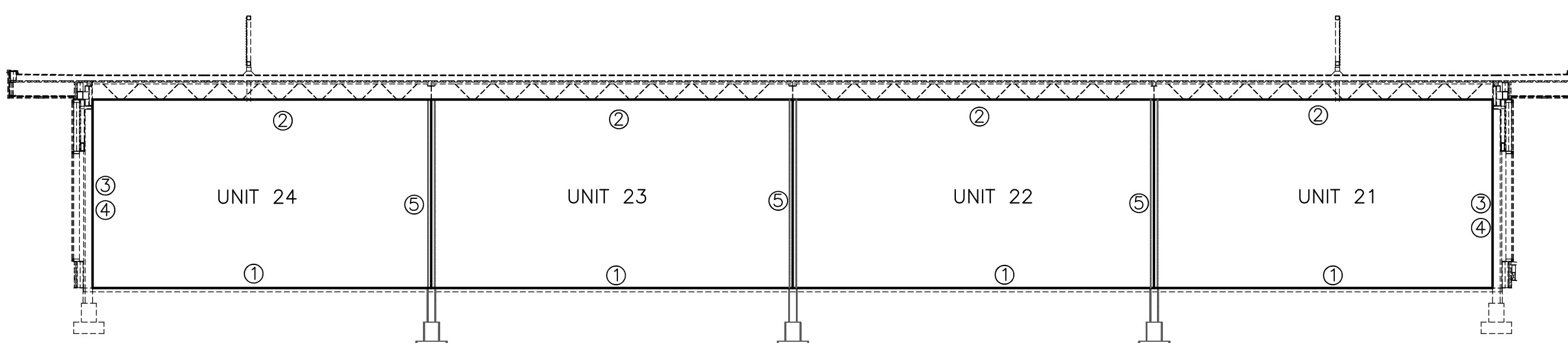

SECTION 'C'-C'  
SECTION ILLUSTRATING TYPICAL UNIT BOUNDARIES UNITS 17 TO 24 (BOTH INCLUSIVE) (NOT TO SCALE)

**LEGEND**

- B DENOTES BALCONY
- ETR DENOTES ELEVATOR
- ETC DENOTES ELECTRICAL
- DENOTES BOUNDARY OF THE UNITS

**UNIT BOUNDARY DEFINITIONS**

- AREAS NOT DESIGNATED AS UNITS ARE COMMON ELEMENTS.
- ① DENOTES HORIZONTAL PLANE ESTABLISHED BY UPPER SURFACE OF CONCRETE FLOOR SLAB AND PRODUCTION THEREOF
  - ② DENOTES HORIZONTAL PLANE ESTABLISHED BY UNIT SIDE LOWER SURFACE OF ROOF TRUSSES AND/OR BEAMS AND PRODUCTION THEREOF
  - ③ DENOTES VERTICAL PLANE ESTABLISHED BY FINISHED EXTERIOR SURFACE OF EXTERIOR DOOR AND DOOR FRAMES, WINDOWS AND WINDOW FRAMES, THE SAID DOORS AND WINDOWS IN CLOSED POSITION, AND THE EXTERIOR OR OUTSIDE SURFACE OF ALL GLASS PANELS CONTAINED THEREIN
  - ④ DENOTES HORIZONTAL PLANE ESTABLISHED BY THE BACKSIDE FACE OF DRYWALL AND PRODUCTION THEREOF
  - ⑤ DENOTES VERTICAL PLANE ESTABLISHED BY CENTRELINE OF DEMISING WALLS AND PRODUCTION THEREOF
  - ⑥ DENOTES VERTICAL PLANE ESTABLISHED BY UNFINISHED EXTERIOR SURFACE OF CONCRETE FOUNDATION WALL AND PRODUCTION THEREOF
  - DENOTES BOUNDARIES OF UNITS
  - DENOTES STRUCTURAL LIMITS

**CERTIFICATE OF DECLARANT**

THIS IS TO CERTIFY THAT:  
THE PROPERTY INCLUDED IN THIS PLAN HAS BEEN LAID OUT INTO UNITS AND COMMON ELEMENTS IN ACCORDANCE WITH OUR INSTRUCTIONS.

**DECLARANT:**

DATED AT \_\_\_\_\_ THIS \_\_\_\_\_ DAY OF \_\_\_\_\_, 20\_\_\_\_.

NAME \_\_\_\_\_  
I HAVE AUTHORITY TO BIND THE CORPORATION

David B. Scarles Surveying Ltd.

ONTARIO LAND SURVEYORS  
4255 Sherwoodlane Blvd., Suite 206, Mississauga, Ontario L4Z 1Y5  
Tel: (905) 273-6840 Fax: (905) 896-4410  
Email: info@dbscarles.co

Calculator	Draftsperson
BJ	PC
Editor	Plan Index No
BC/BJ	R 16

Calculation File	Drawing File	File No.
26-21CALC.DWG	26-4C-21.DWG	26-4C-21